

SHARP SERVICE MANUAL

S3106AYX13BE/

SPLIT TYPE ROOM AIR CONDITIONERS

INDOOR UNIT

MODELS

AH-X08BE/10BE/13BE

AY-X08BE/10BE/13BE

OUTDOOR UNIT

AU-X08BE/10BE/13BE

AE-X08BE/10BE/13BE

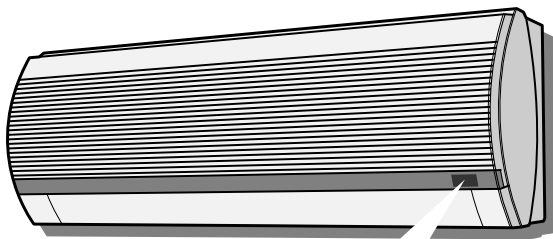

In the interests of user-safety (Required by safety regulations in some countries) the set should be restored to its original condition and only parts identical to those specified should be used.

TABLE OF CONTENTS

	Page
SPECIFICATIONS	2
EXTERNAL DIMENSIONS	4
WIRING DIAGRAMS	6
ELECTRICAL PARTS	9
BLOCK DIAGRAM	10
MICROCOMPUTER CONTROL SYSTEM	12
FUNCTIONS	20
FUNCTION AND OPERATION OF PROTECTIVE PROCEDURES	26
BREAKDOWN DIAGNOSIS PROCEDURE	30
REFRIGERATION CYCLE	30
PERFORMANCE CURVES	32
DISASSEMBLING PROCEDURE	34
OPTION	41
REPLACEMENT PARTS LIST	42

SPECIFICATIONS

ITEMS	MODEL	INDOOR UNIT	OUTDOOR UNIT	INDOOR UNIT	OUTDOOR UNIT	INDOOR UNIT	OUTDOOR UNIT
		AH-X08BE	AU-X08BE	AH-X10BE	AU-X10BE	AH-X13BE	AU-X13BE
Cooling capacity (Min. ~ Max.)	kW	2.2(0.9 – 2.7)		2.8(0.9 – 3.3)		3.6(0.9 – 4.2)	
Moisture removal	Liters/h	0.6		0.7		1.3	

Electrical data

Phase	Single							
Rated frequency	Hz	50						
Rated voltage range	V	198 to 264						
Rated voltage	V	220 - 240						
Rated current ★	A	3.4 – 3.1		4.3 – 4.0		5.5 – 5.1		
Rated input ★	W	730		930		1200		
Power factor ★	%	98 – 98		98 – 97		99 – 98		
Compressor	Type	Hermetically sealed rotary type						
	Model	2RV110N5EA04				HV237A1-S15DK		
	Oil charge	ATMOS M60 or SUNISO 4GDID 260 cm ³				SUNISO 4GSD 455 cc		
Refrigerant system	Evaporator	Bare tube type		Grooved tube type		Grooved tube type		
	Condenser	Louver Fin and Grooved tube type						
	Control	Capillary tube						
	Refrigerant volume	550g		550g		830g		
Noise level (at cooling)	High	dB(A)	33	43	36	43	38	48
	Med.	dB(A)	29	–	32	–	33	–
	Low	dB(A)	27	–	27	–	29	–

Fan system

Drive	Direct drive							
Air flow quantity (at cooling)	High	m ³ /min.	7.5	28	8.7	28	9.3	30
	Med.	m ³ /min.	6.8	–	7.8	–	8.1	–
	Low	m ³ /min.	6.0	–	6.0	–	6.6	–
Fan	Cross flow fan		Propeller fan		Cross flow fan		Propeller fan	

Connections

Refrigerant coupling	Flare type						
Refrigerant tube size Gas, Liquid	3/8", 1/4"				1/2", 1/4"		
Drain piping mm	O.D ø 18						

Others

Safety device	Compressor: Thermal protector							
	Fan motors: Thermal fuse							
	Fuse, Micro computer control							
Air filters	Polypropylene net (Washable)							
Net dimensions	Width	mm	815	780	815	780	815	780
	Height	mm	278	540	278	540	278	540
	Depth	mm	198	269	198	269	198	269
Net weight	kg	9	31	9	33	10	38	

Note: The condition of star "★" marked item are 'ISO5151' : 1994(E), condition T1.

ITEMS	MODEL		INDOOR UNIT	OUTDOOR UNIT	INDOOR UNIT	OUTDOOR UNIT	INDOOR UNIT	OUTDOOR UNIT
			AY-X08BE	AE-X08BE	AY-X10BE	AE-X10BE	AY-X13BE	AE-X13BE
Cooling capacity(Min. ~ Max.)	kW		2.2(0.7 – 2.7)		2.8(0.7 – 3.3)		3.6(0.9 – 4.2)	
Heating capacity(Min. ~ Max.)	kW		3.2(0.7 – 3.6)		3.7(0.7 – 5.0)		4.8(1.0 – 6.2)	
Moisture removal(at cooling)	Liters/h		0.7		0.8		1.3	

Electrical data

Phase			Single					
Rated frequency		Hz	50					
Rated voltage range		V	198 to 264					
Rated voltage		V	220 - 240					
Rated current ★	Cool	A	3.4 – 3.1		4.3 – 4.0		5.5 – 5.1	
	Heat	A	4.2 – 3.9		4.8 – 4.4		6.8 – 6.2	
Rated input ★	Cool	W	730		930		1200	
	Heat	W	910		1050		1480	
Power factor ★	Cool	%	98 – 98		98 – 97		99 – 98	
	Heat	%	98 – 97		99 – 99		99 – 99	
Compressor	Type		Hermetically sealed rotary type					
	Model		HV166A1-S10DK		HV237A1-S15DK			
	Oil charge		455cc (SUNISO 4GSD)		455cc (SUNISO 4GSD)			
Refrigerant system	Evaporator		Louver Fin and Grooved tube type					
	Condenser		Corrugate Fin and Grooved tube type					
	Control		Capillary tube					
	Refrigerant volume		760g		850g		880g	
	De-Ice system		Micro computer controled reversed systems					
Noise level (at cooling)	High	dB(A)	33	43	36	43	38	48
	Med.	dB(A)	29	–	32	–	33	–
	Low	dB(A)	27	–	27	–	29	–

Fan system

Drive			Direct drive					
Air flow quantity (at cooling)	High	m ³ /min.	7.5	28	9.8	27.7	9.3	30
	Med.	m ³ /min.	6.8	–	8.2	–	8.1	–
	Low	m ³ /min.	6.0	–	6.1	–	6.6	–
Fan			Cross flow fan	Propeller fan	Cross flow fan	Propeller fan	Cross flow fan	Propeller fan

Connections

Refrigerant coupling			Flare type					
Refrigerant tube size Gas, Liquid			3/8", 1/4"			1/2", 1/4"		
Drain piping mm			O.D ø 18					

Others

Safety device			Compressor: Thermal protector					
			Fan motors: Thermal fuse					
			Fuse, Micro computer control					
Air filters			Polypropylene net (Washable)					
Net dimensions	Width	mm	815	780	815	780	815	780
	Height	mm	278	540	278	540	278	540
	Depth	mm	198	269	198	269	198	269
Net weight		kg	9	35	10	36	10	39

Note: The condition of star " ★ " marked item are 'ISO5151' : 1994(E), condition T1.

EXTERNAL DIMENSIONS

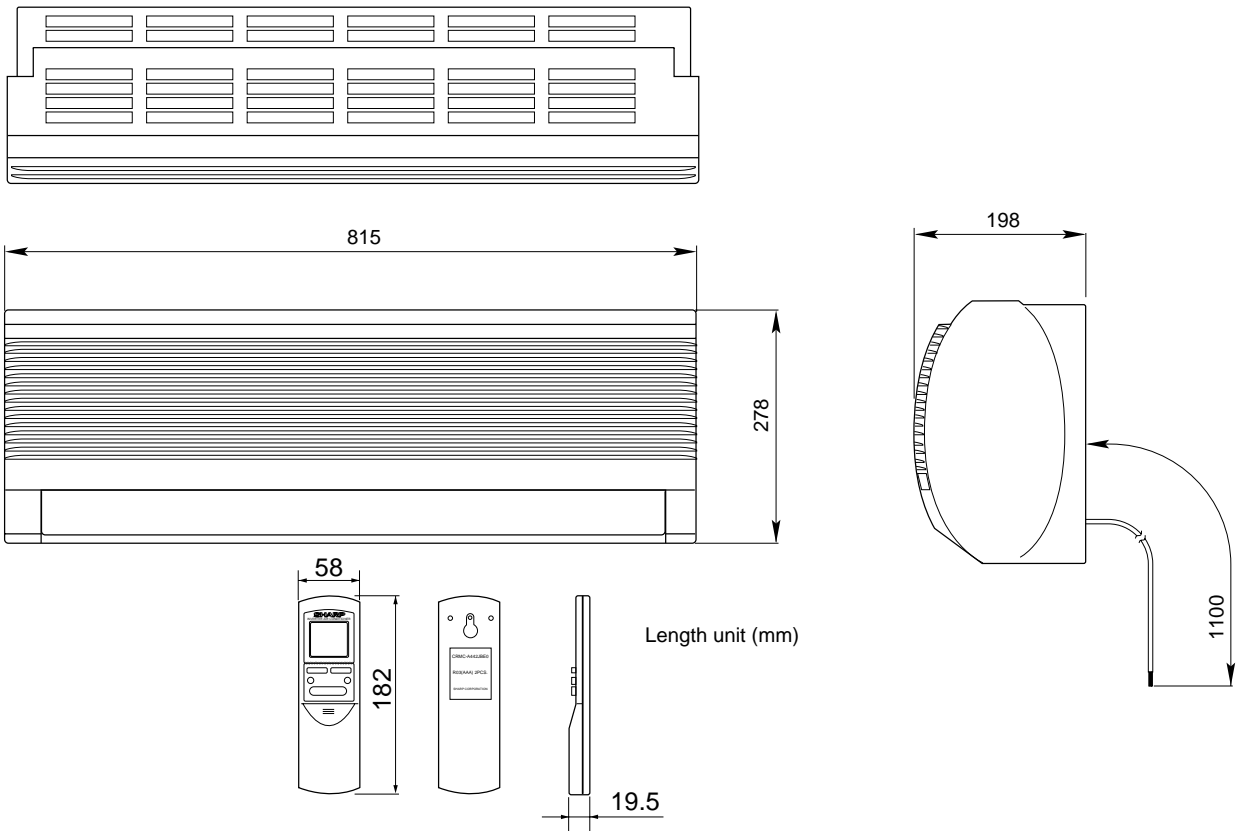

Figure E-1. INDOOR UNIT

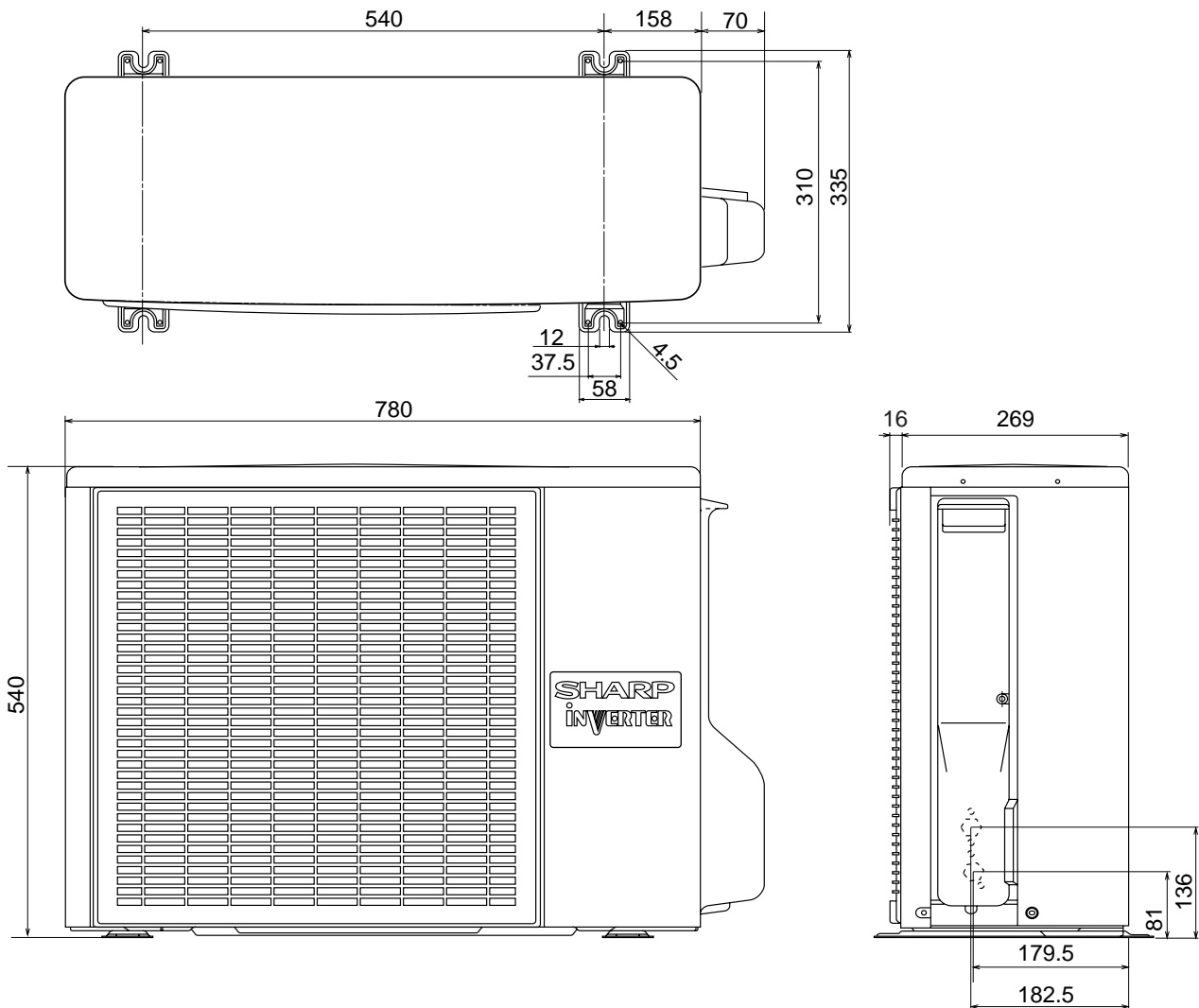

Figure E-2. OUTDOOR UNIT

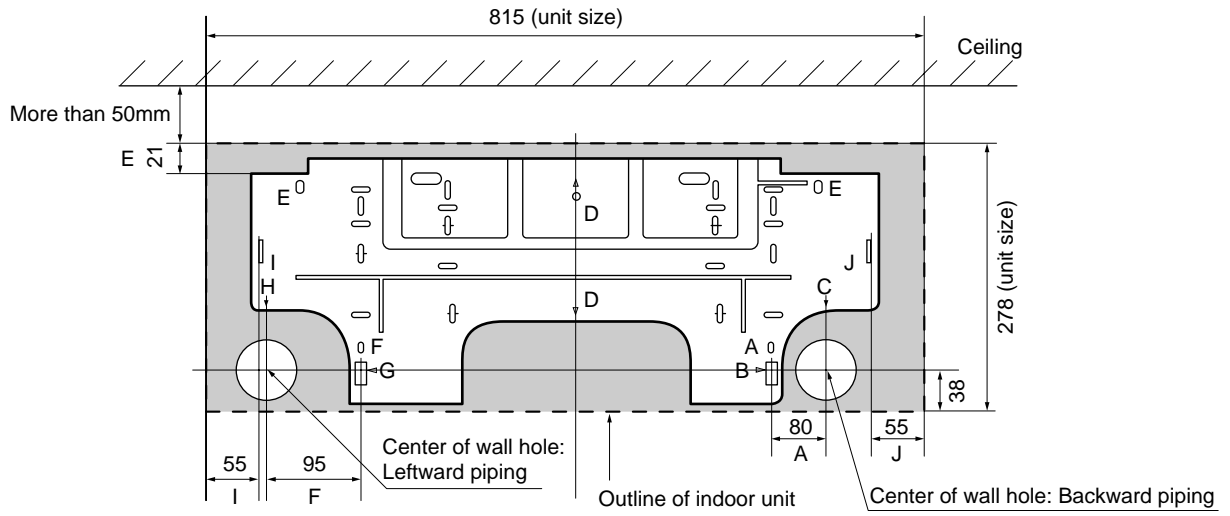

Figure E-3. INSTALLATION DIMENSIONS

WIRING DIAGRAMS

LED INDICATION FOR SELF-DIAGNOSIS

Temperature Indicator Blinking No.	Abnormal contents
1	Short circuit of the outdoor thermistor
2	Overheat of the compressor
3	Abnormal AC current
4	Compressor lock
5	Open circuit of the outdoor thermistor
6	Power module (IPM) abnormality
7	AC overcurrent
14	Abnormal power factor module (AFM)
17	Open circuit of serial signal line
18	Short circuit of serial signal line
19	Abnormal fan motor of indoor unit

< Indication of the abnormal condition >
 LED indicator will blink, if the set
 is in abnormal condition.

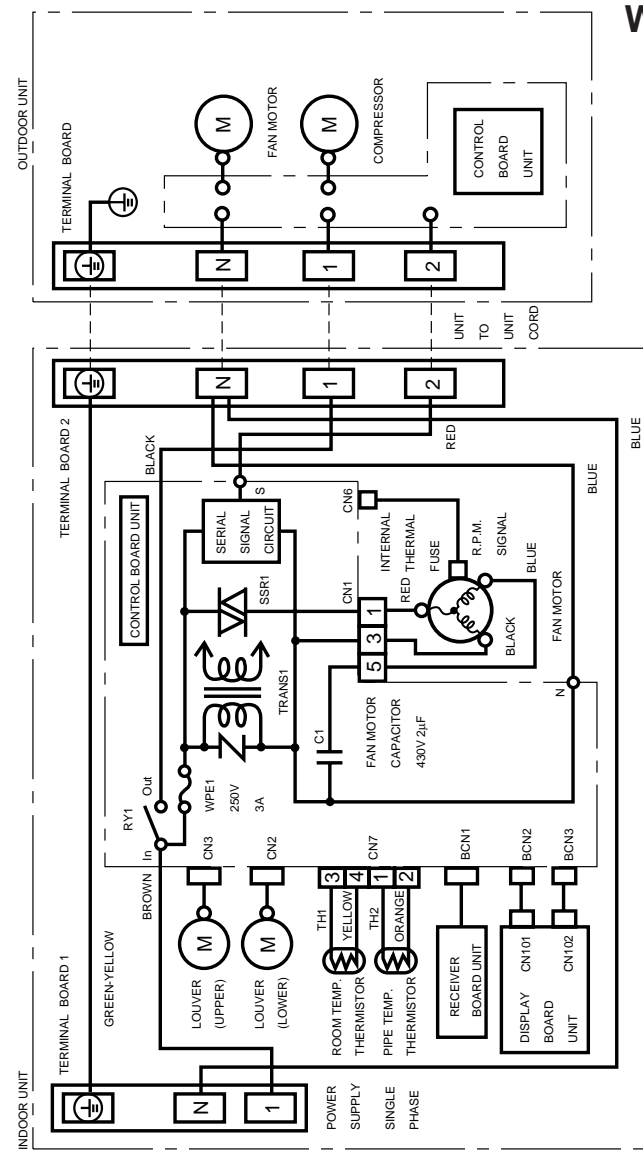
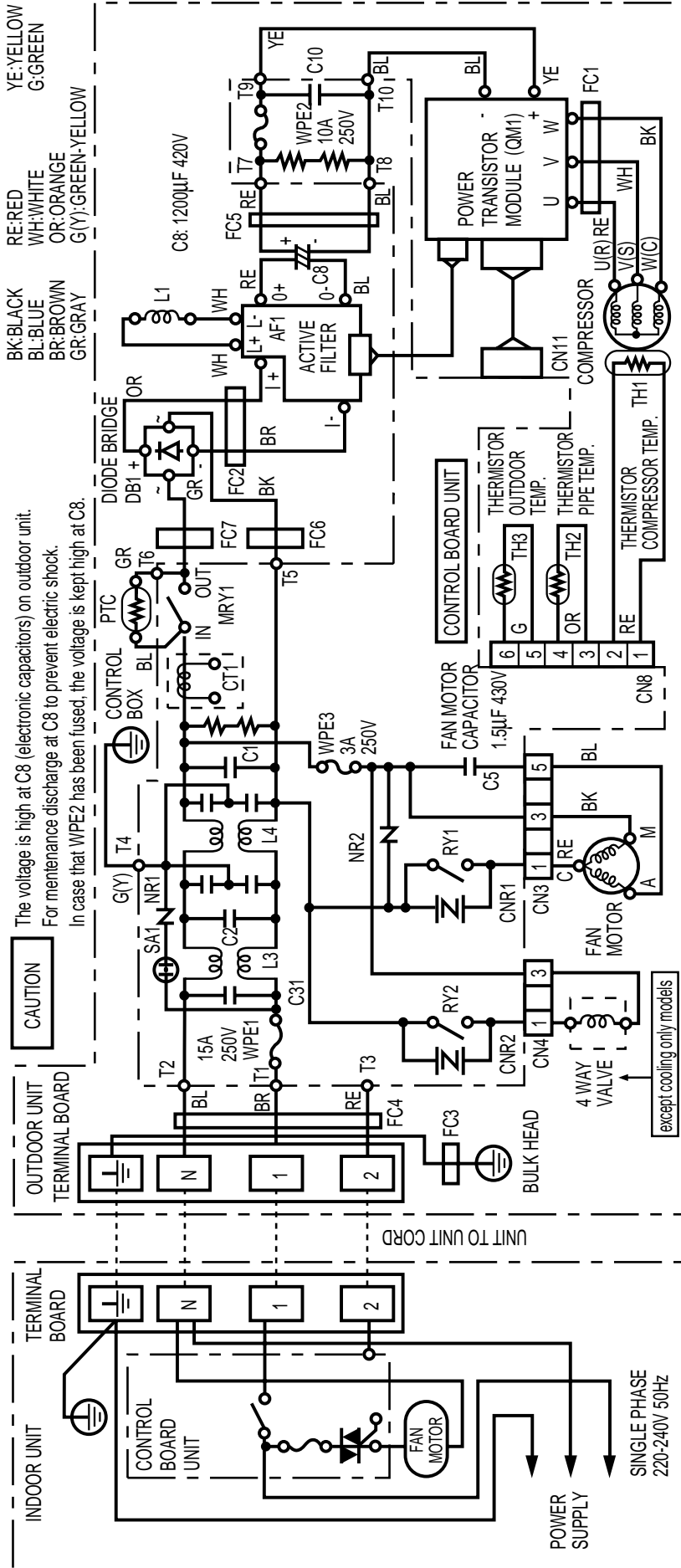

Figure W-1. Wiring Diagram for AH-X08BE/X10BE/X13BE and AY-X08BE/X10BE/X13BE



LED INDICATION OF SELF-DIAGNOSIS

ON OUTDOOR UNIT	LED BLINKING
●	LED turns on
○	Slow flashing (1 time for 2 seconds)
●	Quick flashing (3 times for 2 seconds)

Example: NO.2 Compressor lock

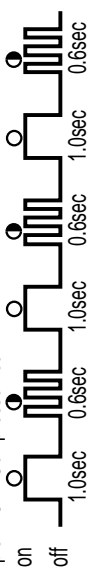

NO.	LED indication pattern	Multifunction part or abnormal condition
1	○	Normal
2	●	Abnormal signal line
3	○	Compressor lock
4	●	Overheat of the compressor

NO.3 Overheat of the compressor



NO.	LED indication pattern	Multifunction part or abnormal condition
5	○○○○○○	Short circuit of the thermistor
6	○○○○○○	Open circuit of the thermistor
7	○○○○○○	AC abnormal current
8	○○○○○○	AC overcurrent
9	○○○○○○○○○○○○	Power factor module error

Figure W-2. Wiring Diagram for AE-X08BE/X10BE

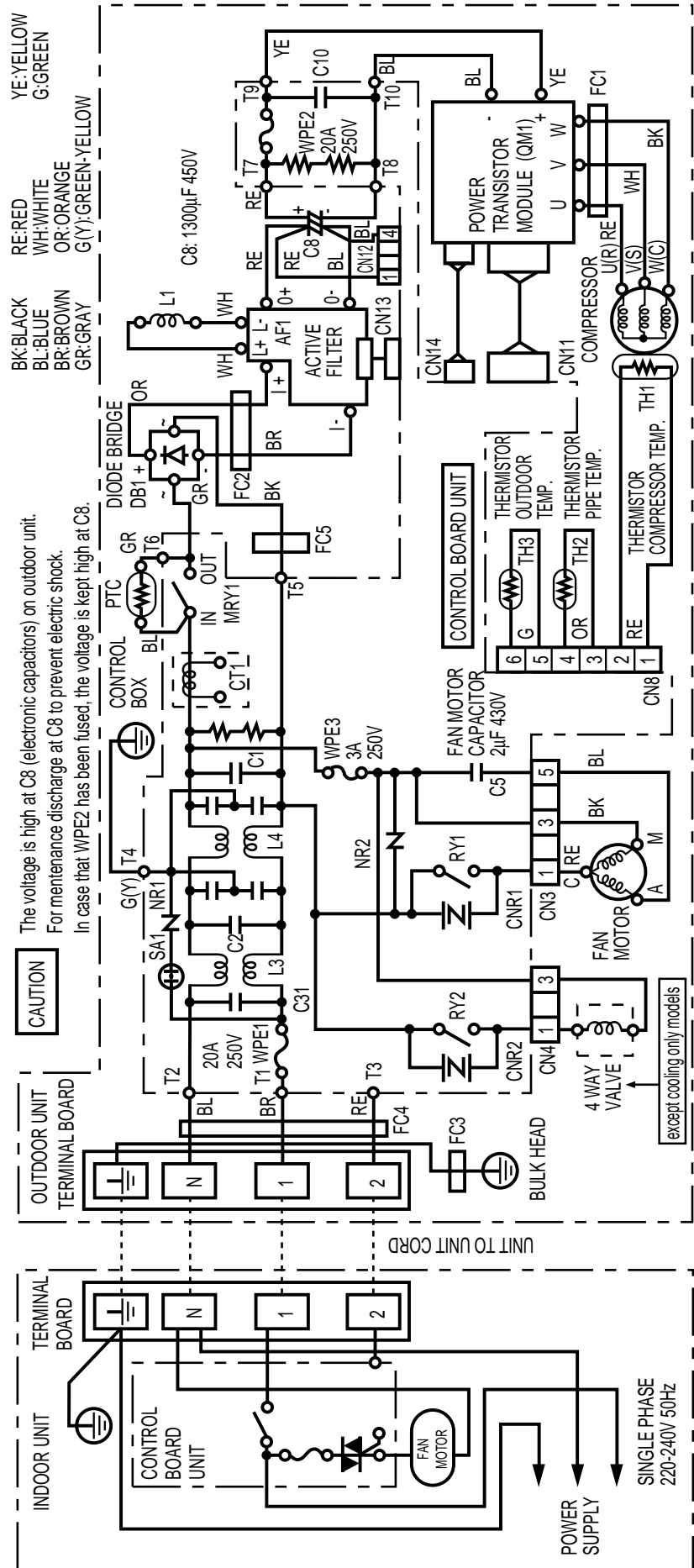

CAUTION
 The voltage is high at C8 (electronic capacitors) on outdoor unit.
 For maintenance discharge at C8 to prevent electric shock.
 In case that WPE2 has been fused, the voltage is kept high at C8.

INDOOR UNIT
 TERMINAL BOARD
 CONTROL BOARD UNIT
 FAN MOTOR
 POWER SUPPLY
 SINGLE PHASE
 220-240V 50Hz

OUTDOOR UNIT
 TERMINAL BOARD
 DIODE BRIDGE
 ACTIVE FILTER
 FAN MOTOR
 COMPRESSOR
 THERMISTOR OUTDOOR TEMP.
 THERMISTOR PIPE TEMP.
 THERMISTOR COMPRESSOR TEMP.

YE: YELLOW
 G: GREEN
 RE: RED
 WH: WHITE
 OR: ORANGE
 G(Y): GREEN-YELLOW
 BK: BLACK
 BL: BLUE
 BR: BROWN
 GR: GRAY

LED INDICATION OF SELF-DIAGNOSIS

NO.	LED indication pattern	Multifunction part or abnormal condition
1	●	LED turns on
2	○	Slow flashing (1 time for 2 seconds)
3	○	Quick flashing (3 times for 2 seconds)

Example: NO.2 Compressor lock



LED INDICATION OF SELF-DIAGNOSIS

NO.	LED indication pattern	Multifunction part or abnormal condition
5	○○○○○	Multifunction part or abnormal condition
6	○○○○○	Short circuit of the thermistor
7	○○○○○	Open circuit of the thermistor
8	○○○○○	AC abnormal current
9	○○○○○	AC overcurrent

Example: NO.3 Overheat of the compressor



Figure W-3. Wiring Diagram for AU-X13BE and AE-X13BE

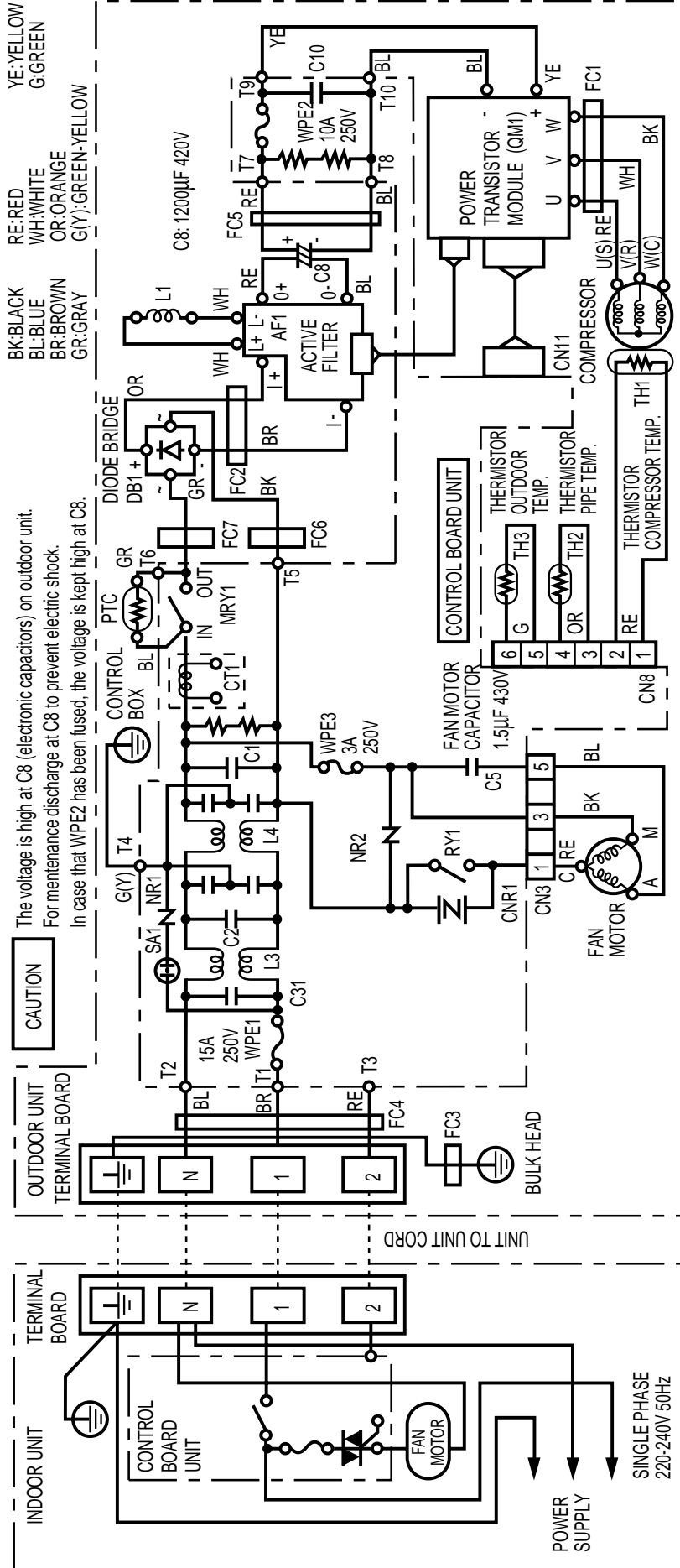

LED INDICATION OF SELF-DIAGNOSIS

ON OUTDOOR UNIT	
LED BLINKING	
●	LED turns on
○	Slow flashing (1 time for 2 seconds)
◐	Quick flashing (3 times for 2 seconds)

Example: NO.2 Compressor lock

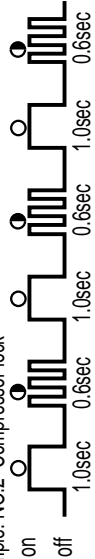

NO.	LED indication pattern	Multifunction part or abnormal condition	NO.	LED indication pattern	Multifunction part or abnormal condition
1	○	Normal	5	○○○○○	Short circuit of the thermistor
2	●	Abnormal signal line	6	○○○○○	Open circuit of the thermistor
3	○	Compressor lock	7	○○○○○	AC abnormal current
4	◐	Overheat of the compressor	8	○○○○○	AC overcurrent
		QM1 (IPM) Abnormality	9	○○○○○	Power factor module error

NO.3 Overheat of the compressor

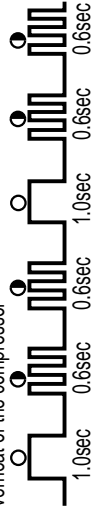

Figure W-4. Wiring Diagram for AU-X08BE/X10BE

ELECTRICAL PARTS

For Model AH-X08BE/X10BE/X13BE, AY-X08BE/X10BE/X13BE

DESCRIPTION	MODEL	REMARKS	SITE
Indoor fan motor	ML-A901	220 - 240V, 50Hz	AH, AY
Indoor fan motor capacitor	–	430V, 2 μ F	AH, AY
Transformer	–	Primary; AC 220 - 240V, 50Hz Secondary; AC19V, 50Hz	AH, AY
WPE1	–	QFS-GA027JBE0 (250V, 3A)	AH, AY

For Model AE-X10BE

Compressor	HV237A1-S15DK	3-PHASE Induction motor	AU, AE
Outdoor fan motor	ML-A902	220 - 240V, 50Hz 220V, 60Hz	AU, AE
Outdoor fan motor capacitor	–	430V, 1.5 μ F	AU, AE
WPE1	–	QFS-GA033JBZZ(15A, 250V)	AU, AE
WPE2	–	QFS-GA015JBE0(10A, 250V)	AU, AE
WPE3	–	QFS-GA008JBE0(3A, 250V) or QFS-GA027JBE0 (3A, 250V)	AU, AE AU

For Model AE-X08BE

Compressor	HV166A1-S10DK	3-PHASE Induction motor	AU, AE
Outdoor fan motor	ML-A902	220 - 240V, 50Hz 220V, 60Hz	AU, AE
Outdoor fan motor capacitor	–	430V, 1.5 μ F	AU, AE
WPE1	–	QFS-GA033JBZZ(15A, 250V)	AU, AE
WPE2	–	QFS-GA015JBE0(10A, 250V)	AU, AE
WPE3	–	QFS-GA008JBE0(3A, 250V) or QFS-GA027JBE0 (3A, 250V)	AU, AE AU

For Model AU-X08BE/X10BE

Compressor	2RV110N5EA04	3-PHASE Induction motor	AU, AE
Outdoor fan motor	ML-A902	220 - 240V, 50Hz 220V, 60Hz	AU, AE
Outdoor fan motor capacitor	–	430V, 1.5 μ F	AU, AE
WPE1	–	QFS-GA033JBZZ(15A, 250V)	AU, AE
WPE2	–	QFS-GA015JBE0(10A, 250V)	AU, AE
WPE3	–	QFS-GA008JBE0(3A, 250V) or QFS-GA027JBE0 (3A, 250V)	AU, AE AU

For Model AU-X13BE/X13BE

Compressor	HV237A1-S15DK	3-PHASE Induction motor	AU, AE
Outdoor fan motor	ML-A903	220 - 240V, 50Hz 220V, 60Hz	AU, AE
Outdoor fan motor capacitor	–	430V, 2.0 μ F	AU, AE
WPE1	–	QFS-GA014JBE0(20A, 250V)	AU, AE
WPE2	–	QFS-GA019JBE0(20A, 250V)	AU, AE
WPE3	–	QFS-GA008JBE0(3A, 250V) or QFS-GA027JBE0 (3A, 250V)	AU, AE AU

BLOCK DIAGRAMS

INDOOR UNIT

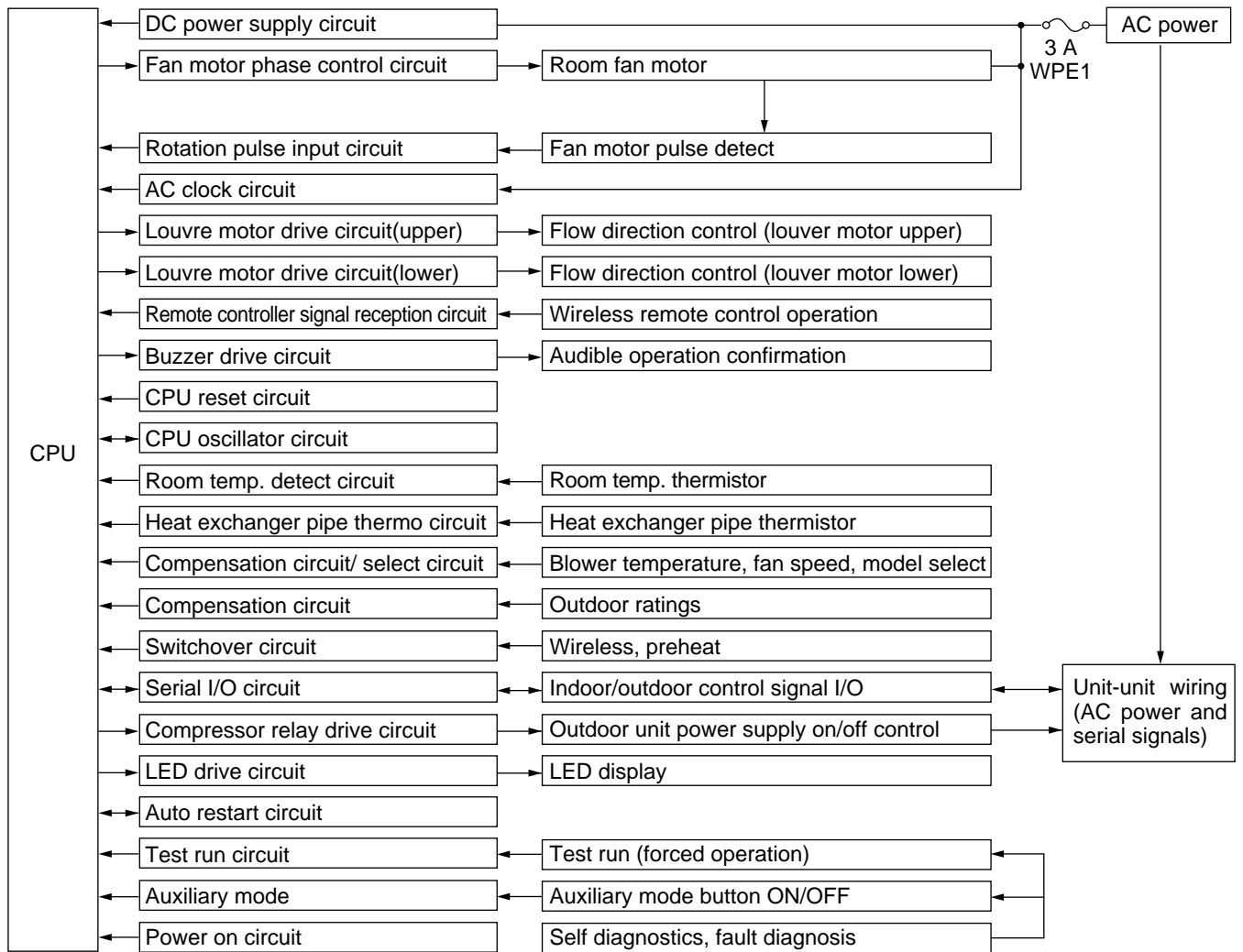

OUTDOOR UNIT for AU-X08BE/X10BE and AE-X08BE/X10BE

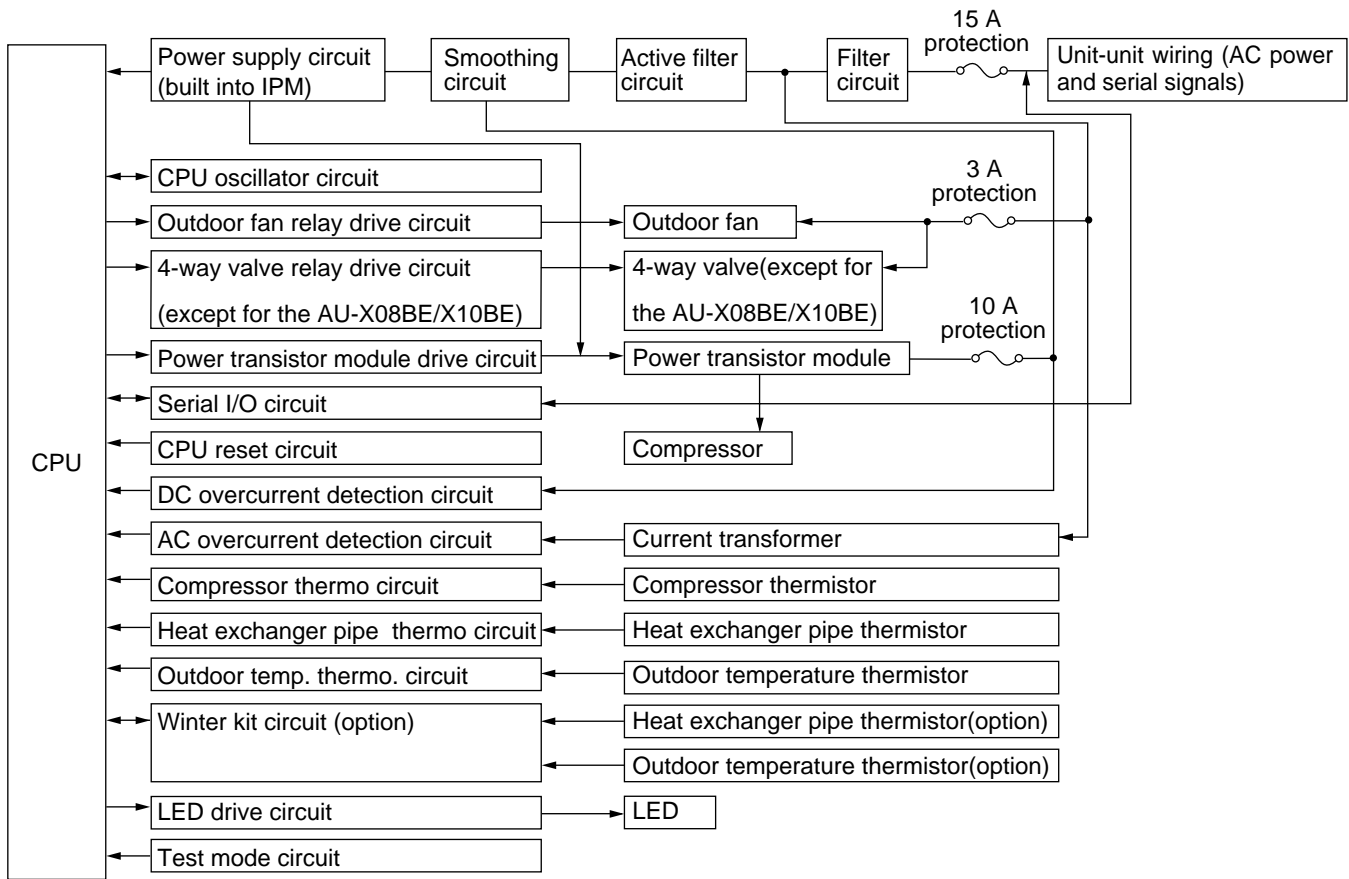

OUTDOOR UNIT for AU-X13BE and AE-X13BE

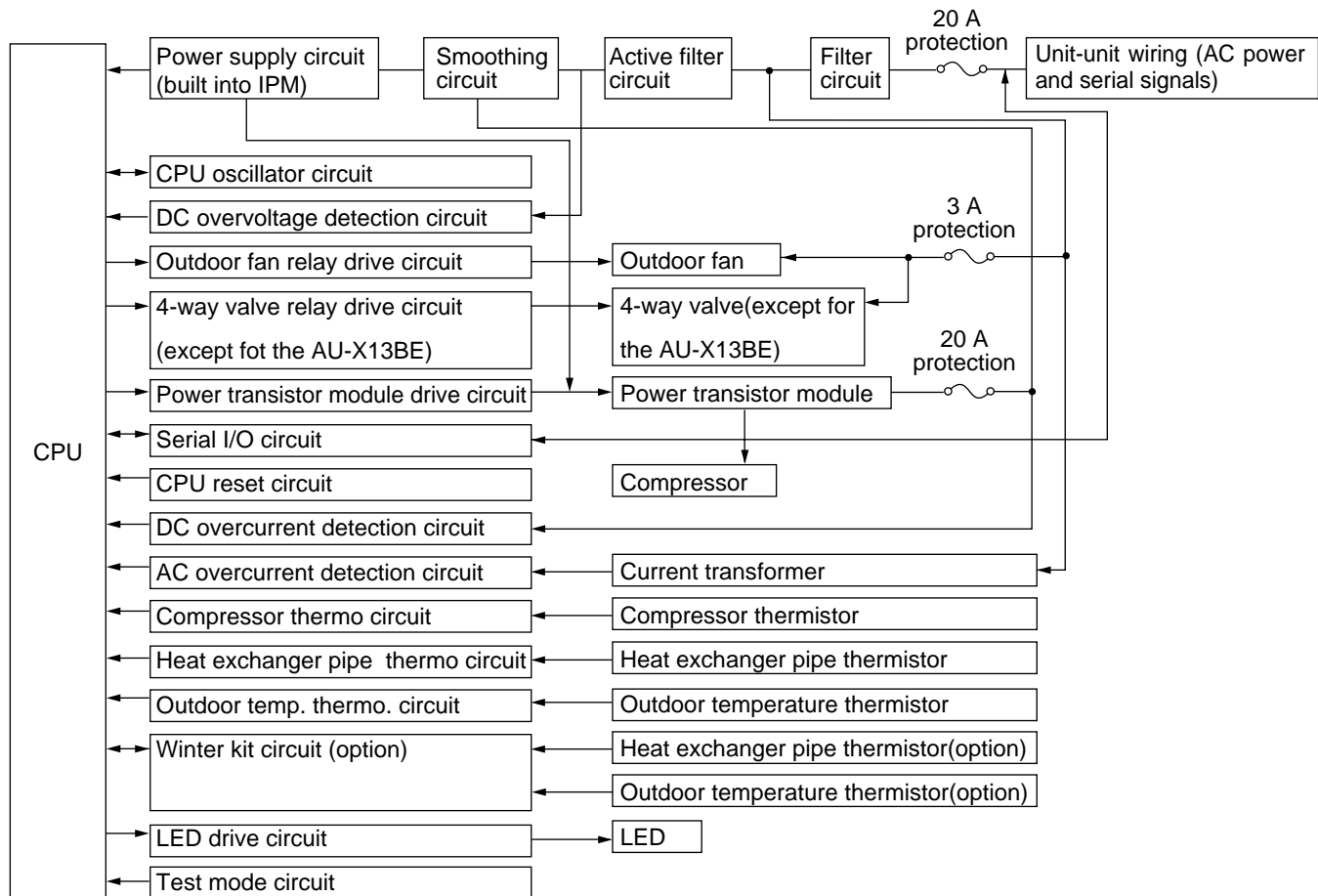

MICROCOMPUTER CONTROL SYSTEM

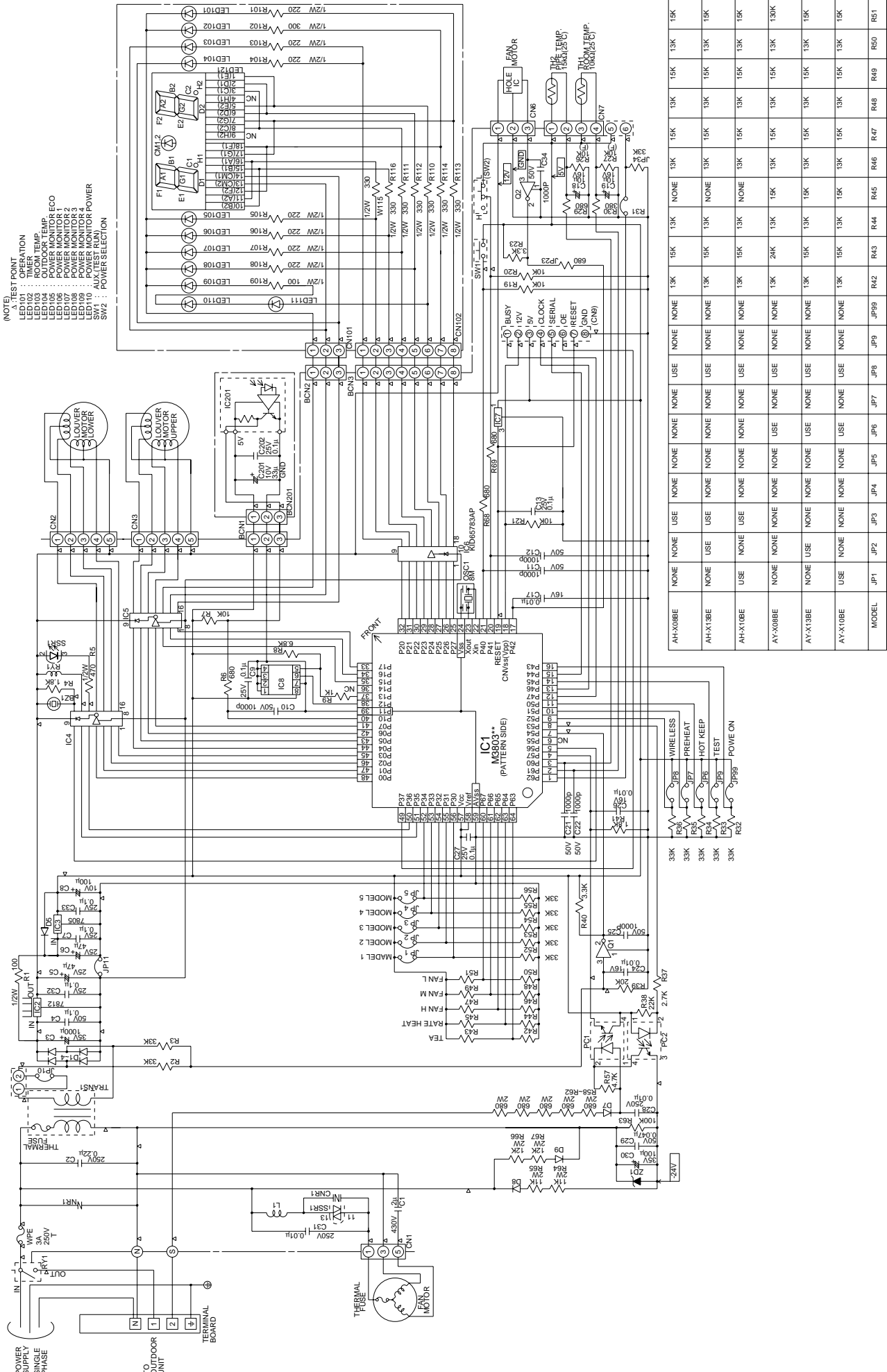

Figure L-1. Electronic Control Diagram for AH-X08BE/X10BE/X13BE and AY-X08BE/X10BE/X13BE

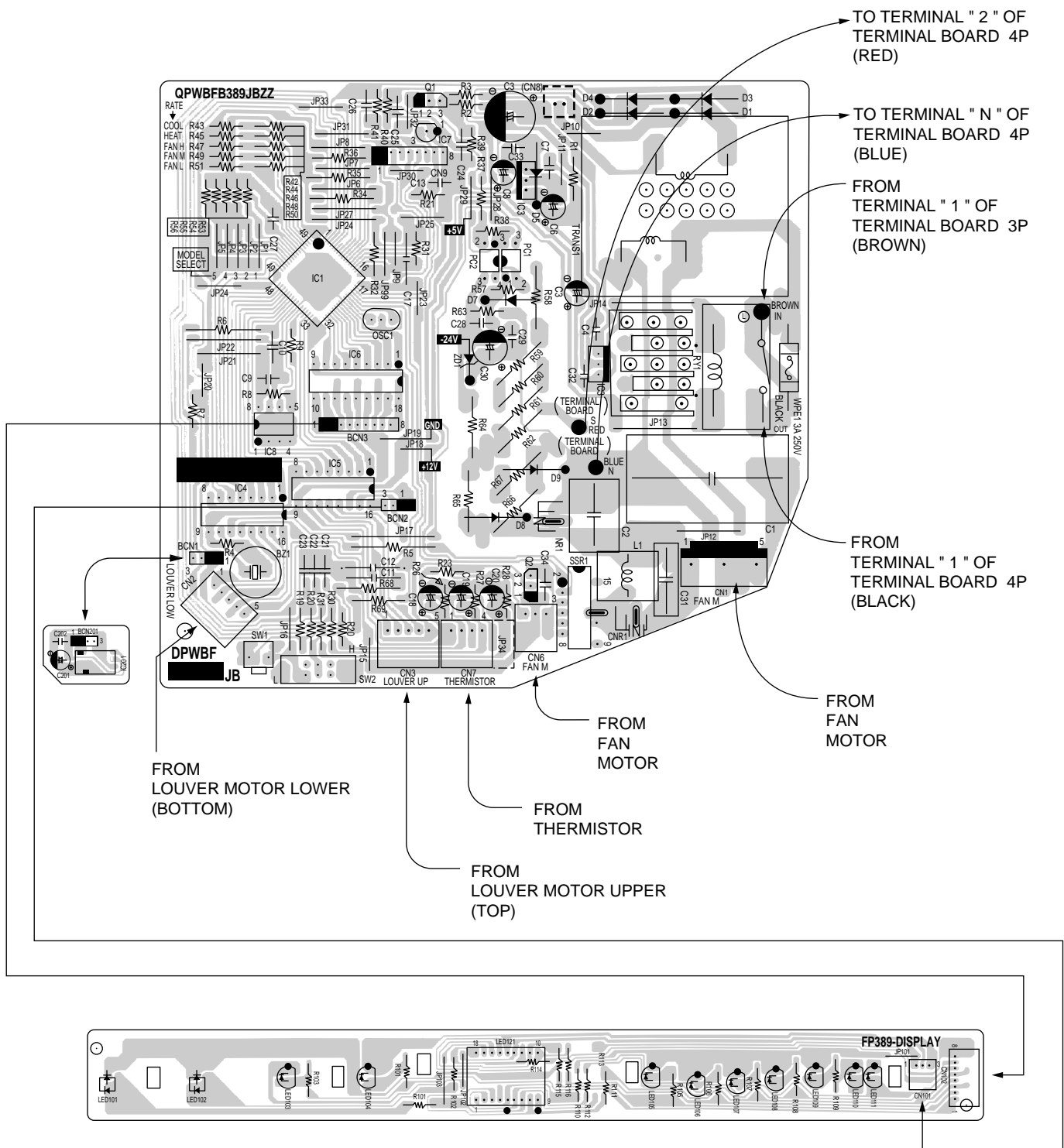

Figure L-2 Printed Wiring Board for AH-X08BE/X10BE/X13BE and AY-X08BE/X10BE/X13BE

NOTE
 1. Δ MARK IS TEST POINT.
 2.  IF NOT SPECIFIED 1/4W (RESISTOR)

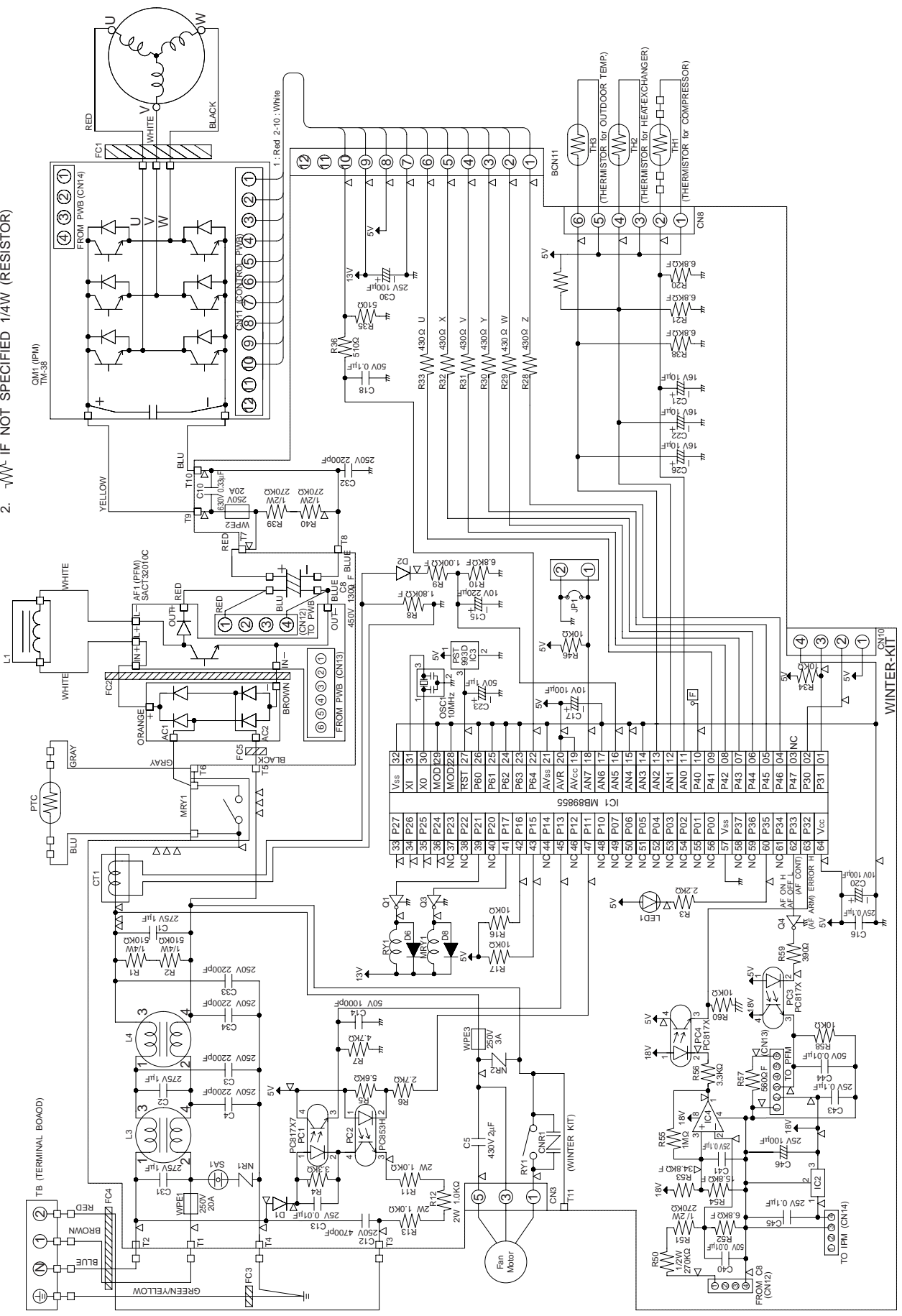

Figure L-4. Electronic Control Circuit Diagram for AU-X13BE

NOTE
 1. Δ MARK IS TEST POINT.
 2.  IF NOT SPECIFIED 1/4W (RESISTOR)

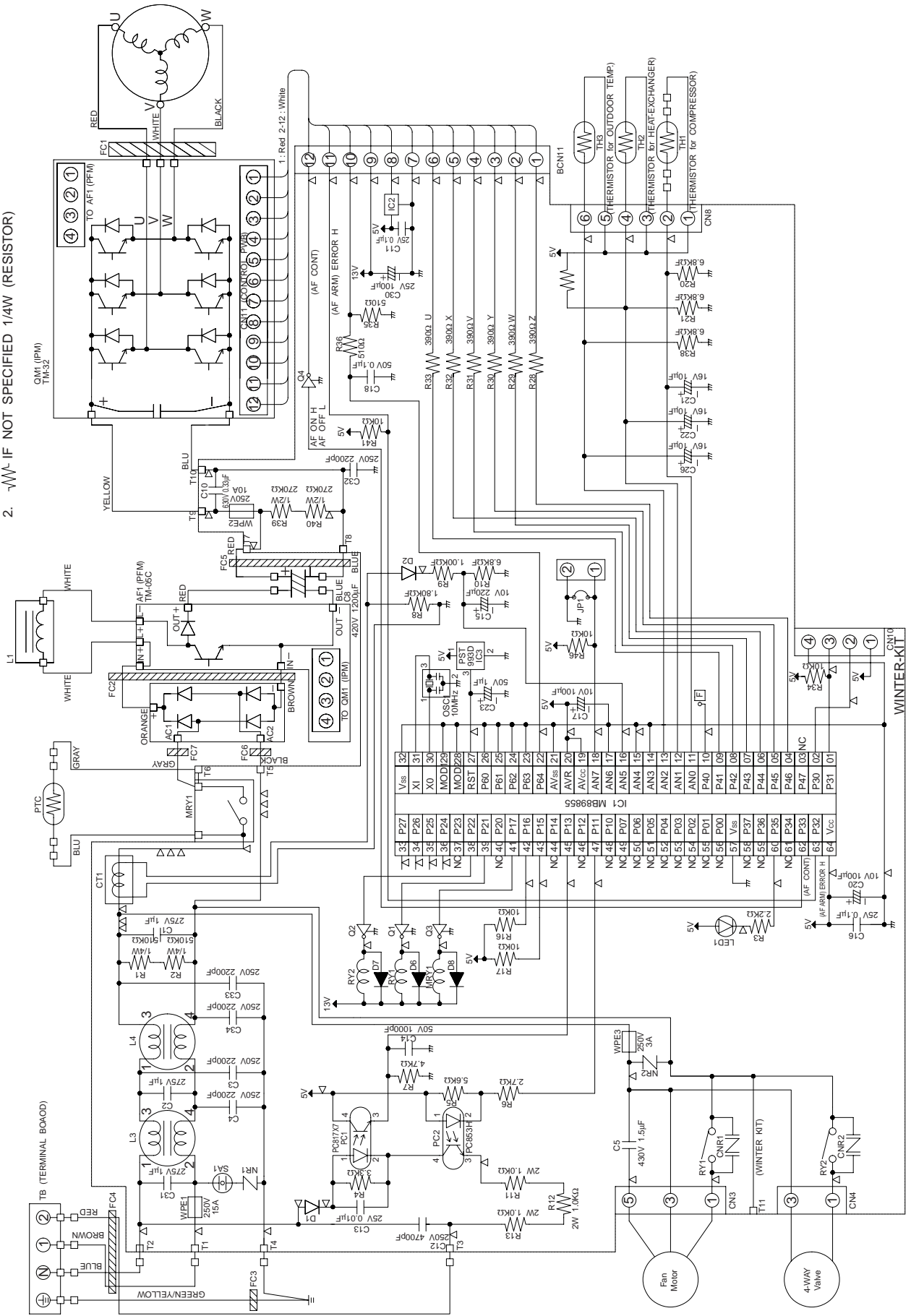

Figure L-5. Electronic Control Circuit Diagram for AE-X08BE/X10BE

NOTE
 1. Δ MARK IS TEST POINT.
 2. \sim IF NOT SPECIFIED 1/4W (RESISTOR)

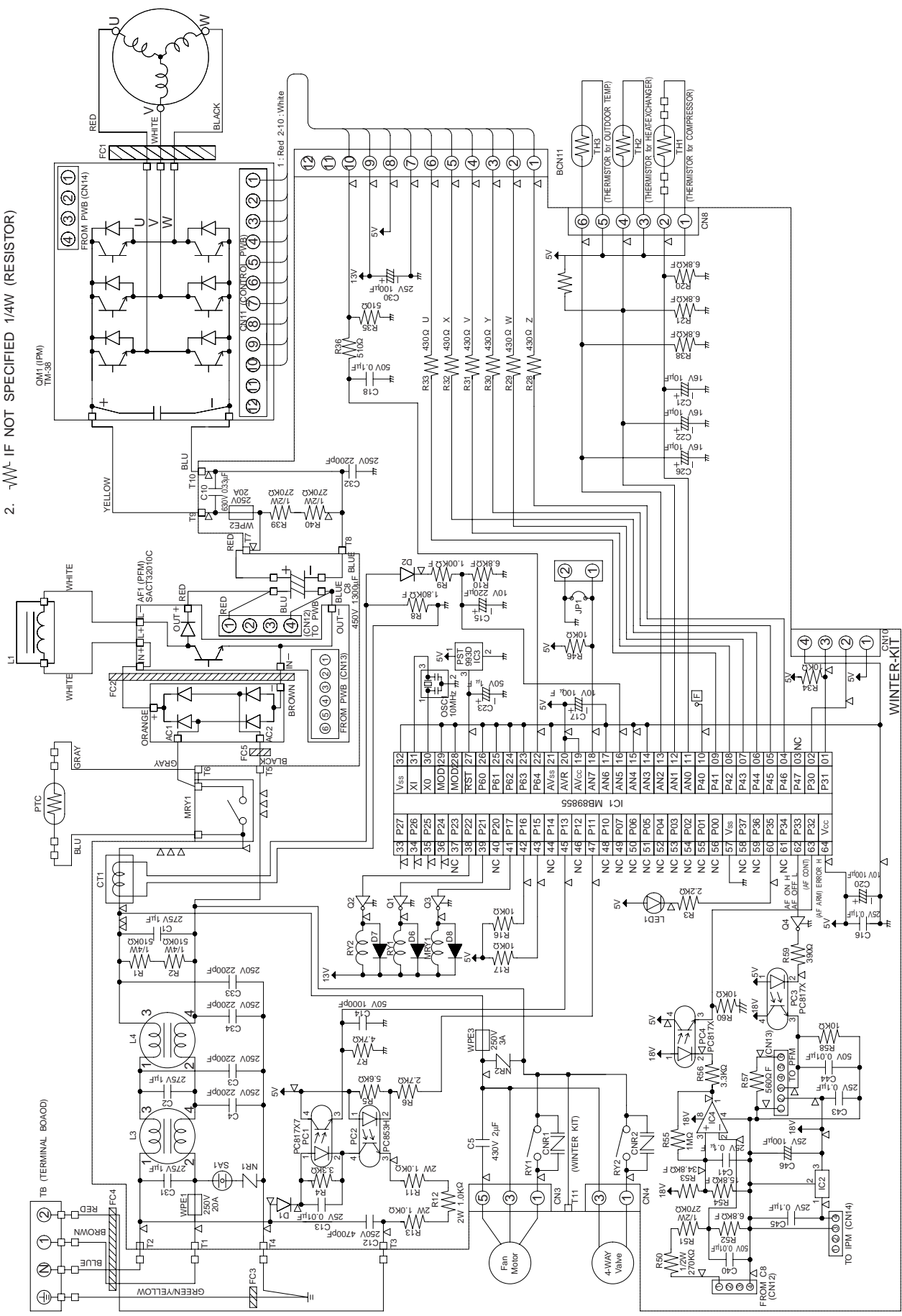

Figure L-6. Electronic Control Circuit Diagram for AE-X13BE

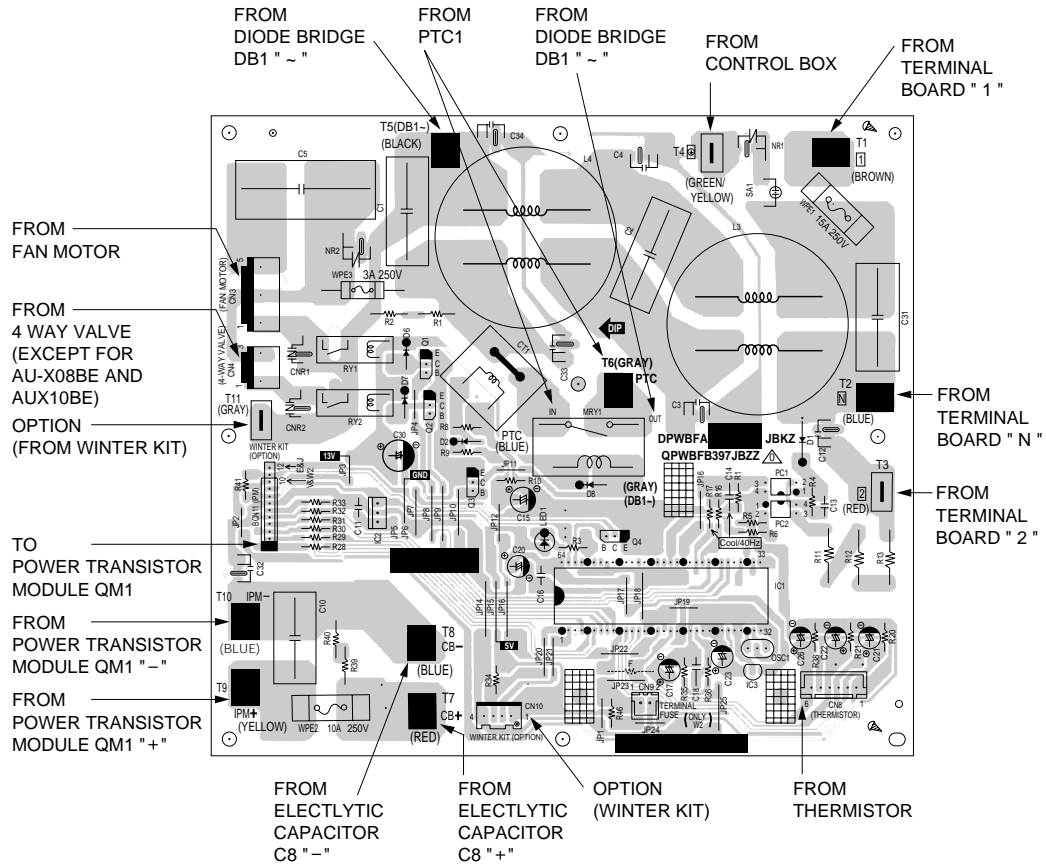

Figure L-7 Printed Wiring Board for AU-X08BE/X10BE and AE-X08BE/X10BE

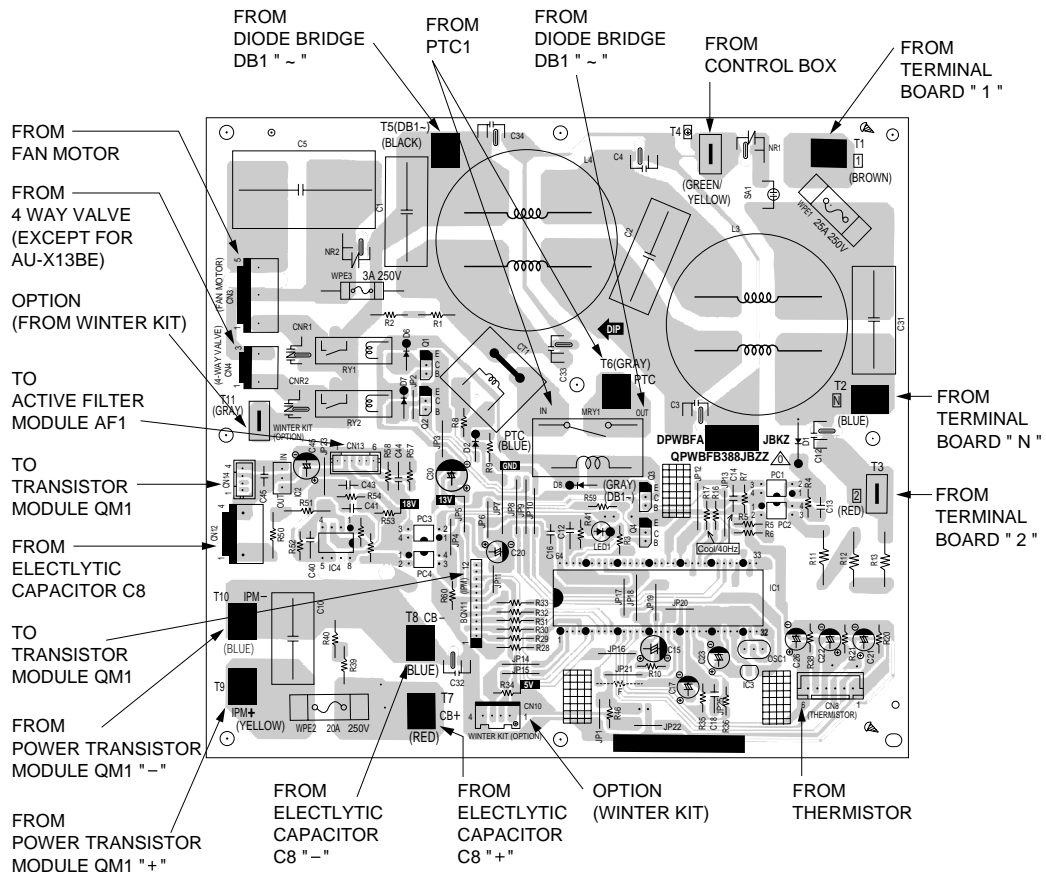

Figure L-8 Printed Wiring Board for AU-X13BE and AE-X13BE

FUNCTIONS

AH-X08BE/X10BE/X13BE are not provided with the heating function.

1. INDOOR UNIT

1-1 Temperature Adjustment

a. Normal control

Proportional control (P control)

When the temperature zone changes, this control changes the frequency by one rank to move closer to the set value.

Integral control (I control)

When the temperature zone has set time in the same zone, this control changes the frequency by one rank to move closer to the set value. (Excluding the h zone.)

b. Initial control

The initial frequency is determined as shown in the tables below based on the difference between the temperature adjustment setting at the beginning of operation and the room temperature. After operation begins, normal control is performed and therefore the correspondences in the tables below will not hold.

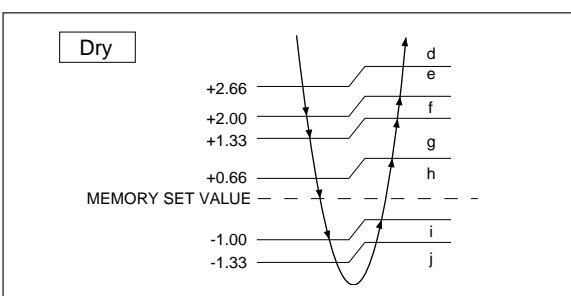
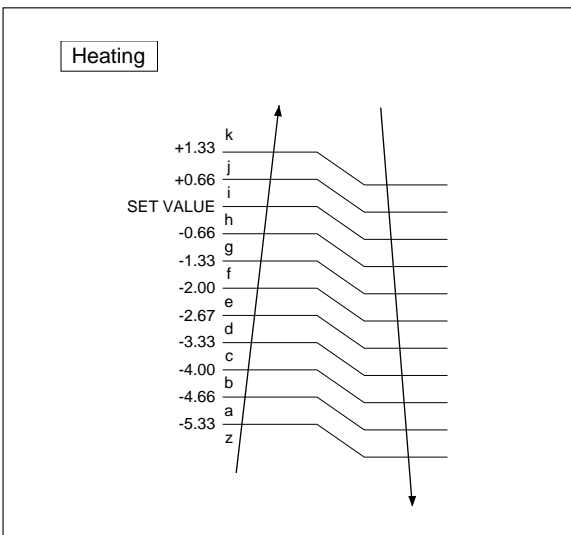
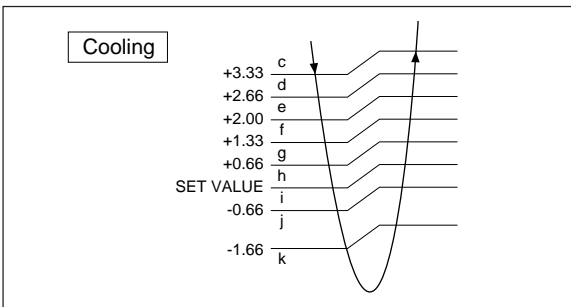

Cooling		Heating		Dry	
Room temp. zone	Frequency Code	Room temp. zone	Frequency Code	Room temp. zone	Frequency Code
c	9	k	OFF (Hot keep fan)	d	5
d	8	j	1	e	4
e	7	i	1	f	3
f	5	h	2	g	2
g	3	g	3	h2	2
h	2	f	4	h1	1
i	1	e	5	i	1
j	OFF	d	6	j	0
k	OFF	c	8		
		b	A		
		a	B		
		z	C		

Although the initial value of the h zone is 1, it changes to 2 after a lapse of 15 minutes.

Full power operation only

c. Temperature adjustment

The temperature adjustment range is changed by changing the operating mode with the operation switch.

(1) Heating

If the room temperature is in the z zone when operation begins, proportional/integral control is not performed, and the machine runs at frequency code c full power until the i zone is reached. When the i zone is reached, the frequency changes to the frequency code determined by fuzzy calculation, and after that proportional/integral control is performed.

(2) Cooling

If the room temperature is in the c zone when operation begins, proportional/integral control is not performed, and the machine runs at frequency code 9 power until the i zone is reached. When the h zone is reached, the frequency changes to the frequency code determined by fuzzy calculation, and after that proportional/integral control is performed.

(3) Dry

After operation begins, 2 minutes (running at the h zone) of the room temperature is stored in memory, and that becomes the set value.

(4) Circulation

The frequency code 0 is sent to the outdoor machine, and only the fan of the indoor machine runs, the compressor does not run.

1-2 Indoor fan control

This control uses the thermistor for the indoor heat exchanger to control cold air blowing prevention, the indoor fan, and overheating prevention.

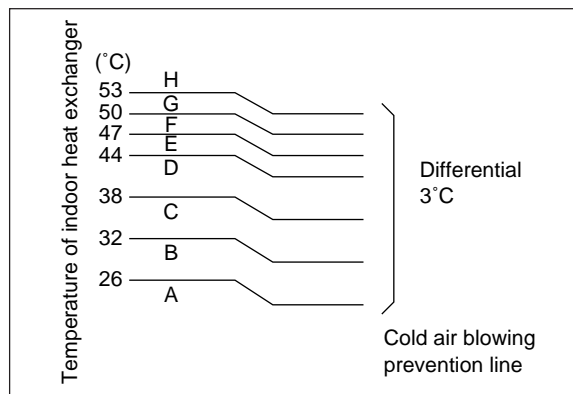

(1) Control for indoor freezing prevention

If the temperature of the indoor heat exchanger stays below approximately 0°C for four minutes during cooling or dry, this control stops the compressor. Over 2°C the compressor will run again.

(2) Control for cold air blowing prevention

When heating begins, this control stops the indoor fan until the temperature of the indoor heat exchanger reaches 26°C. It also stops the fan if the temperature goes below 23°C during operation.

(3) Indoor fan and operating frequency

The indoor fan has 12 speeds, and changing is done in four stages, "Auto", "High", "Med", and "Low". The relations between the indoor fan speed, air quantity setting, operating frequency, and indoor heat exchanger are shown in the following charts.

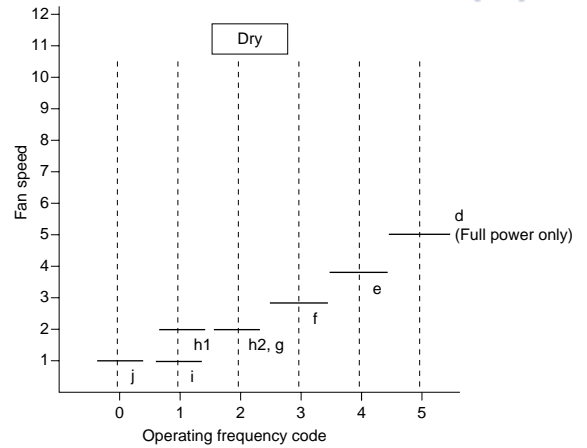

COOLING

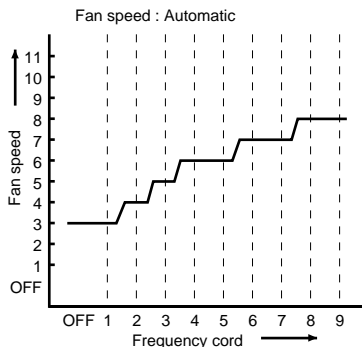
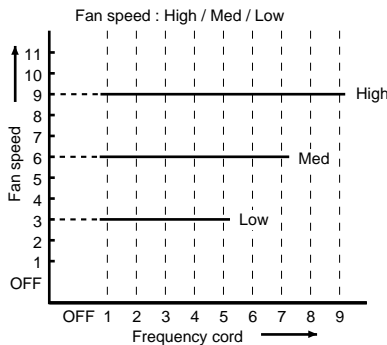

HEATING

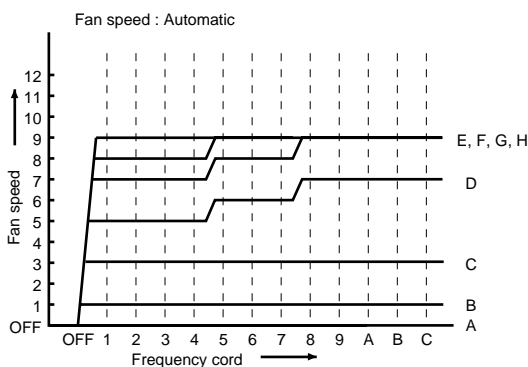
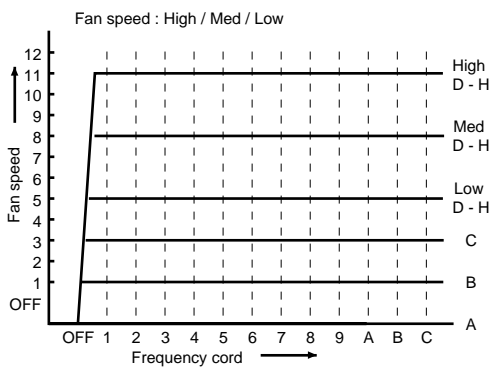

1-3 Hot keep

If the room temperature is in the j or k zone during heating, the compressor is turned on and off to prevent overheating.

The fan goes off 30 seconds after the compressor goes off.

Zone	Compressor intermittent time	Fan
J	3 min. on - 3 min. off	Same as Compressor
K	3 min. on - 8 min. off	After "3 min. on - 3 min.off" is repeated 4 times, the compressor goes off, and only the fan continues to repeat "3 min. on - 8 min.off".

1-4 Automatic operation

The operating mode and temperature setting are determined by the room temperature and the external air temperature.

The operating mode will changeover automatically with the following condition.

Room temperature (°C)	※ Outdoor temperature (°C)					
	0	10	18	28	34	
29	※ Cooling (26°C)	※ Cooling (25°C)	※ Cooling (24°C)	Cooling (24°C)	Cooling (25°C)	Cooling (26°C)
21	Heating (24°C)	Heating (23°C)	Heating (22°C)	(Dry) (Room temperature - 2°C)		

Room temperature (°C) ※ When the cooling operation only can use winter kit

- From cooling to heating
Cooling mode will changeover to heating mode when condition of indoor temperature 1.7°C lower than the set temperature conditions for 5 minutes.
- From heating to cooling
Heating mode will change over to cooling mode when condition of indoor temperature 1.3°C higher than the set temperature conditions for 25 minutes under Hot keep condition.
- When the set temperature is adjusted within the range of ±2°C by the remote control's key. (▼ ▲), the changeover judgement room temp. will also be shifted within the range of ±2°C.

1-5 ON-timer

The ON-timer is set by pressing the ON-timer button. In order to attain the set temperature at the set time, the operation starting time is corrected by fuzzy computing one hour before the set time.

1-6 OFF-timer

The OFF-timer is set by pressing the OFF-timer button. Operation is as follows:

	Set temperature
Cooling Heating	By fuzzy computing Set the shift up time Final (Cooling setting + 1°C) (Heating setting - 3°C)
Dry	Same as above (Final setting + 1°C)

*During Heating

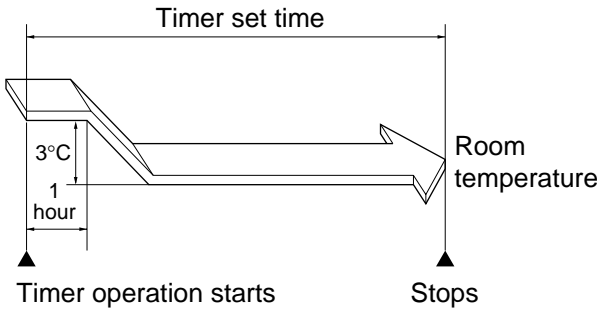

*During Cooling / Dry

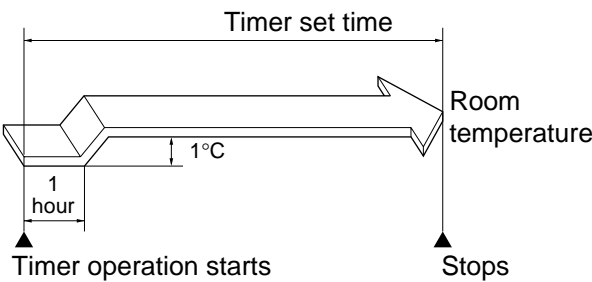

1-7 Swing louvres

Louvres are moved by a stepping motors to perform swing and fixing in the set position. If the "FLOW DIRECTION" button is pressed during swing, they will stop. If the "FLOW DIRECTION" button is pressed while they are stopped, they will swing.

1-8 Restart control

Once the compressor stops, this control prevents it from starting again for 3 minutes. It also prevents starting for 80 seconds immediately following plugging into the power outlet.

1-9 One-hour operation

If this button is pressed when operation is stopped, operation will begin and then stop after 1 hour. If pressed when it is operating, will stop after one hour.

1-10 Full power operation

Immediately begins cooling or heating at maximum power and air flow.

- (During heating) Operates at setting of 32°C.
- (During cooling) Operates at setting of 18°C.

1-11 Preheat

When heating is stopped, supplies a small amount of power to the compressor to make heating start more quickly. Operates when the indoor temperature sensor and external air sensor detect that the room temperature and outdoor temperature are low (below 18°C and 5°C, respectively). Stops when the

compressor chamber temperature rises above 25°C. Preheat does not operate for 2 hours after heating is stopped. After that, it goes on for 180 minutes and then stops for 30 minutes, repeatedly.

1-12 Power ON start

If a jumper wire is inserted into the place indicated JP99 on the indoor control board, and the power plug is inserted. cooling or heating will be automatically determined by the room temperature sensor on the main unit, and operation will begin.

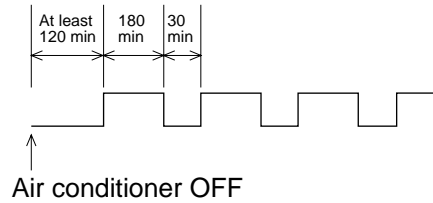

1-13 Compressor relay

(1) It is ON during operation, and when operation is stopped, goes OFF after a delay of 100 seconds (not immediately).

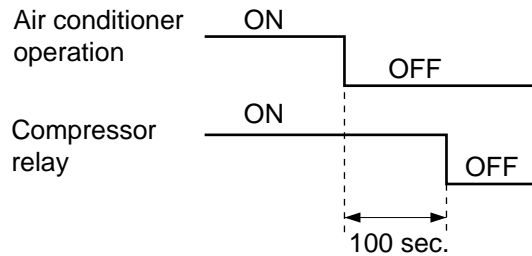

(2) The minimum OFF time of the relay is 80 seconds. It will not go ON again before 80 seconds elapses.

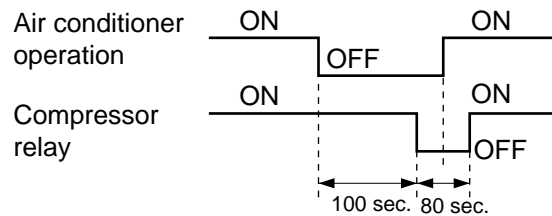

(3) If air conditioner operation is turned on again during the 100 second delay before the compressor relay goes off, the compressor relay will stay on.

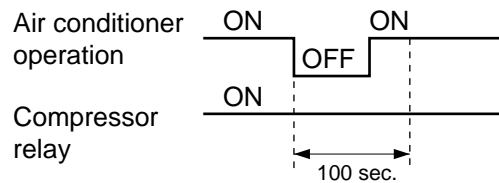

1-14 Power selector (AY-X13BE, AH-X13BE)

Operation power "H" (High) or "L" (Low) can be selected by switching the POWER SELECTOR slide switch located above the AUX. button.

	Power select	Cooling	Heating
AY-X13BE	H	7.9A	10.5A
	L	7.7A	7.2A
AH-X13BE	H	7.9A	—
	L	7.7A	—

1-15 Auto Restart

When power failure occurs, after power is recovered, the unit will automatically restart in the same setting which were active before the power failure.

Operating mode (Cool, Heat, Dry)

- Temperature adjustment (within 2°C range) automatic operation
- Temperature setting
- Fan setting
- Air flow direction
- Power ON/OFF
- Automatic operation mode setting
- Swing louver

Setting not memorized

- Timer setting
- Full power setting

1-16 Indoor/outdoor temperature display

Every time the Temperature check button is pressed on the remote control, the display changes in the order of indoor temperature → outdoor temperature → no display. The temperature is displayed on the temperature indicator on the main unit to be referred to for energy saving.

(When the unit is not running, the display changes between indoor temperature and no display.) Indoor temperature is the temperature of the suction air measured by the room thermistor, and outdoor temperature is that measured by the outdoor temperature thermistor. When indoor temperature is displayed, the indoor LED on the main unit is lit, and when outdoor temperature is displayed, the outdoor LED is lit. For 90 seconds after the operation starts, - - is displayed instead of the actual outdoor temperature since it is still being measured. Because of the effect of the exchanger, the unit cannot confirm the exact indoor temperature right after the operation is terminated. Therefore, for one hour since the operation is stopped, the indoor temperature immediately before the operation is stopped is displayed. After over one hour since it is stopped, the unit displays the actual room temperature at that point.

1-17 Error diagnostic display

(a) Indoor unit

- (1) When an error is detected, all relays are turned off. At the same time, the details of the error are displayed by flashing the number corresponding to the type of the error. The details can also be displayed by pressing down the emergency operation switch for 5 seconds or more in the state of operation stop. However, if the operation is continued only in the serial open state and the state remains unchanged after that, the main relay is turned off in 8 minutes. In the serial short state, the error is not displayed and the operation is continued. If the unit stays in the same state, the main relay is turned off in 8 minutes. Although the error is not displayed, it is memorized and can be displayed when it is recalled.
- (2) If the operation is stopped and the emergency operation button is pressed down for 5 seconds or more, the self-diagnosis memory can be recalled.
- (3) Details of self-diagnosis (error mode) are

informed by the flashing number as well as the lighting pattern of the operation lamp which flashes with the timer lamp. (For details, refer to Error diagnostic method.)

AU-X08BE/10BE/13BE are not provided with the heating function.

2. OUTDOOR UNIT

2-1 Defrost operation (AE-X08BE/X10BE/13BE)

(1) Overview

Defrosting begins during heating if the conditions for compressor operation time and outdoor heat exchanger temperature are met.

When defrosting begins, the indoor and outdoor fans stop. Defrosting stops when the temperature of the outdoor heat exchanger goes above approximately 5°C or defrosting time exceeds 13 minutes.

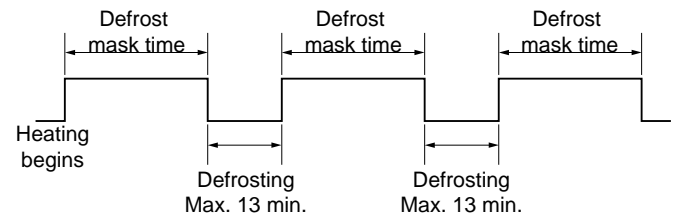

(2) Defrosting

If the compressor operation time is more than 20 minutes in the heating mode and the outdoor air temperature and outdoor heat exchange temperature satisfy the defrosting conditions, the defrosting operation is started.

When the outdoor sheat-exchanger temperature reaches approx. 5°C or above or when the defrosting time exceeds 12 minutes, the defrosting operation is quit.

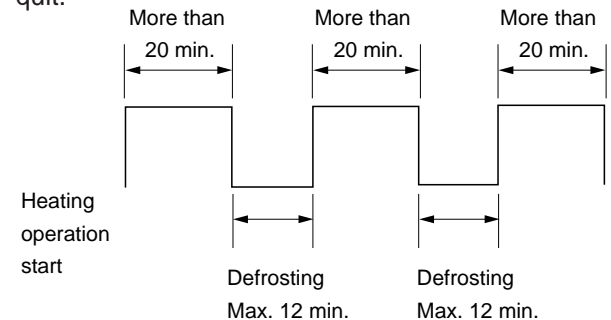

(3) During defrosting

When defrosting begins, the compressor stops. Approximately 1 minutes later, the compressor reactivates in the refrigeration cycle, and the outdoor heat exchanger is defrosted.

Each mode is as follows:

The outdoor fan is stopped

The operating frequency is as shown in the table below The indoor fan is stopped

(4) Defrost stop

When defrosting time exceeds 13 minutes When the temperature of the outdoor heat exchanger rises above approximately 5°C Defrost stop is determined by either of the above conditions, and the compressor is stopped. At the same time, the outdoor fan go ON. The compressor is reactivated in the heating cycle 1 minute after it was stopped, and normal control resumes.

2-2 Frequency control

(1) AC current peak control

Model	Set valve	
	Cool	Heat
AE-X08BE	7.0A	6.5A
AE-X10BE	7.0A	8.5A
AE-X13BE	7.9A	10.5A
AU-X08BE	6.0A	—
AU-X10BE	6.5A	—
AU-X13BE	7.9A	—

- (2) Control for prevention of indoor heat exchanger overheating. If the temperature of the indoor heat exchanger exceeds the overheating prevention line 1 or 2 during heating, the operating frequency is lowered by approximately 5 to 10 Hz. After that, the frequency is lowered by approximately 5Hz once every 60 seconds or 10 Hz once every 120 seconds. When the temperature of the indoor heat exchanger goes below the overheating prevention line 1, the frequency is raised by approximately 5 Hz once every 60 seconds, and normal operation is restored. If the frequency is lowered to minimum frequency without the temperature of the outdoor heat exchanger decreasing and this condition lasts for 1 minute, the compressor will be stopped.

Operating frequency	Overheating prevention line 1 (Lower 5Hz)								
	AE-X13BE	120Hz ~	113Hz	106Hz	100Hz~	50Hz~	43Hz~	37Hz ~	~ 37Hz
	AE-X08BE	~ 90Hz	88Hz ~	83Hz ~	75Hz ~	50Hz ~	43Hz ~	37Hz ~	~ 37Hz
	AE-X10BE		~ 92Hz	~ 88Hz	~ 83Hz	~ 75Hz	~ 50Hz	~ 43Hz	
During normal operation	[°C]	46.11	49.59	51.87	53.29	54.26	53.29	52.34	51.41
During full power operation	[°C]	49.14	51.87	54.75	56.25	58.32	56.76	55.74	54.26

Operating frequency	Overheating prevention line 1 (Lower 5Hz)								
	AE-X13BE	120Hz ~	113Hz	106Hz	100Hz~	50Hz~	43Hz~	37Hz ~	~ 37Hz
	AE-X08BE	~ 90Hz	88Hz ~	83Hz ~	75Hz ~	50Hz ~	43Hz ~	37Hz ~	~ 37Hz
	AE-X10BE		~ 92Hz	~ 88Hz	~ 83Hz	~ 75Hz	~ 50Hz	~ 43Hz	
During normal operation	[°C]	48.26	51.87	51.87	55.24	56.25	55.24	54.26	53.29
During full power operation	[°C]	51.41	51.87	53.77	58.32	59.94	58.32	57.27	56.25

- (3) Control for prevention of outdoor heat exchanger overheating. If the temperature of the outdoor heat exchanger exceeds the overheating prevention line 1 or 2 during cooling, the operating frequency is lowered by approximately 5 to 15 Hz.

After that, the frequency is lowered by approximately 5 once every 60 seconds or approximately 15Hz once every 120 seconds. When the temperature of the outdoor heat exchanger goes below the overheating prevention clear line, the frequency is raised by approximately 5 Hz once every 60 seconds, and normal operation is restored. If the frequency is lowered to minimum frequency without the temperature of the outdoor heat exchanger decreasing and this condition lasts for 1 minute, the compressor will be stopped.

Overheating prevention line 1	56°C	Lower 5Hz once every 60 seconds
Overheating prevention line 1	58°C	Lower 15Hz once every 120 seconds
Overheating prevention line 1	55°C	

- 4) Control for prevention of discharge overheating

If the discharge temperature exceeds approximately (AU-X13BE:101°C except AU-X13BE:105°C) during compressor operation, the operating frequency is lowered by approximately 5 Hz. After that, the frequency is lowered by approximately 5 Hz once every 60 seconds. When the discharge temperature goes below approximately (AU-X13BE:100°C except AU-X13BE:104°C), the frequency is raised by approximately 5 Hz once every 60 seconds, and normal operation is restored.

If the frequency is lowered to minimum frequency without the discharge temperature decreasing and this condition lasts for 1 minute, the compressor will be stopped.

- (5) Control for prevention of indoor heat exchanger freezing

If the temperature of the indoor heat exchanger goes below approximately 5°C during cooling (only Full power operation), the operating frequency is lowered by approximately 5 Hz. After that, the frequency is lowered by approximately 5 Hz once every 60 seconds. When the temperature of the indoor heat exchanger rises above approximately 5°C, the frequency is raised by approximately 5 Hz once every 60 seconds, and normal operation is restored.

If the temperature of the indoor heat exchanger goes down to approximately 0°C and this condition continues for 4 minutes, the compressor is stopped.

When the temperature rises above approximately 2°C, normal operation is restored.

2-3 Overcurrent protection

(1) Compressor lock detection

If the set value (AE-X08BE: 3.2 A, except AE-X08BE: 2.7A) of AC current is exceeded in 6 seconds when operation begins, operation is stopped. In this case, the compressor outdoor fan does not stop, and 170 seconds after operation is stopped, another try will be made. Three retries are allowed. On the fourth retry, a complete stop request signal is sent to the indoor unit, and the outdoor unit will remain stopped until reset is performed. At this time, the 3-minute delay for control of the outdoor unit will not function; therefore, do not cancel by removing the plug and cutting the power.

(2) DC overcurrent detection, AC overcurrent detection

To protect against overcurrent due to sudden changes in load, the compressor is stopped if the set value (AE-X08BE/AU-X13BE: 47A, AE-X08/10BE, AU-X08BE/10BE/13BE: 26A) DC is exceeded in the DC section, or the set value (AE-X08/10BE, AU-X08/10BE: 11A, AE-X13BE, AU-X13BE: 13A) AC is exceeded in the AC section. In this case, the outdoor fan does not stop, and 170 seconds after operation is stopped, another try will be made. Three retries are allowed. On the fourth retry, a complete stop request signal is sent to the indoor unit, and the outdoor unit will remain stopped until reset is performed. At this time, the 3-minute delay for control of the outdoor unit will not function; therefore, do not cancel by removing the plug and cutting the power.

2-4 Compressor protector control

If the temperature of the compressor chamber exceeds 114°C, the compressor is stopped. In this case, the outdoor fan does not stop, and when the compressor chamber temperature decreases to 100°C three minutes after operation is stopped, another try will be made. Three retries are allowed. On the fourth retry, a complete stop request signal is sent to the indoor unit, and the outdoor unit will remain stopped until reset is performed. At this time, the 3-minute delay for control of the outdoor unit will not function; therefore, do not cancel by removing the plug and cutting the power.

2-5 Power transistor module protector

If the temperature of the chips in the power transistor module exceeds 105 °C, the compressor is stopped.

In this case, the outdoor fan does not stop, and when the temperature of the chips in the power transistor module decreases to 105 °C 170 seconds after operation is stopped, another try will be made.

Three retries are allowed. On the fourth retry, a complete stop request signal is sent to the indoor unit, and the outdoor unit will remain stopped until reset is performed. At this time, the 3-minute delay for control of the outdoor unit will not function; therefore, do not cancel by removing the plug and cutting the power.

2-6 Power factor module

(AE-X08BE, AE-X10BE, AU-X08BE, AU-X10BE)

If a voltage error (over 400 V), current error (over 17 A), or temperature error (over 90°C) is detected in the power factor module, 170 seconds the compressor is stopped.

(AE-X13BE, AU-X13BE)

If a voltage error (over 420V) is detected at power factor module output voltage, 170seconds the compressor is stopped.

In this case, the outdoor fan does not stop, and 170 seconds after operation is stopped, another try will be made. Three retries are allowed. On the fourth retry, a complete stop request signal is sent to the indoor unit, and the outdoor unit will remain stopped until reset is performed. At this time, the 3-minute delay for control of the outdoor unit will not function; therefore, do not cancel by removing the plug and cutting the power.

2-7 Serial signals

(1) Serial signals consist of all 96-bit signals.

(2) If the outdoor unit does not receive a serial signal, it will stop approximately 30 seconds later. Note that this is true only of normal operation; in test mode, it does not stop and operation takes place based on the test mode commands.

FUNCTION AND OPERATION OF PROTECTIVE PROCEDURES

NO	Function	Operation				Self diagnostic display	
		Description	Detection time	Restart condition	Restart times	Indoor	Outdoor
1	Indoor fan lock	Stops operation if no revolution pulse signal is input from the indoor fan motor for one minute.	When indoor fan is revolving	Operation OFF	No limit	Yes	No
	Indoor fan rpm error	Stops operation if the revolution pulse signal from the indoor fan indicates low rpm (approximately 300 rpm or less).					
2	Indoor freezing guard	Lowers the operating frequency if the temperature of the indoor heat exchanger goes below 5°C during cooling. Stops the compressor if the temperature stays below 0°C for 4 minutes.	During cooling and dry	Automatically restarts when the exchange temperature rises above the freezing prevention temperature (above 2°C)	No limit	No	No
3	Indoor overheating control	Lowers the operating frequency if the temperature of the indoor heat exchanger rises above the overheating temperature during heating. Stops the compressor if the temperature stays above the overheating temperature for 1 minute at minimum frequency or less. Set values for overheating temperature During normal operation: 46°C to 54°C During full power operation: 49°C to 58°C	During heating	Automatically restarts when the exchange temperature goes below the overheating temperature.	No limit	No	No
4	DC overcurrent	Stops the compressor if a current of approximately 47/26A or more flows in the power transistor module. Also stops the compressor if the temperature of the power transistor module is exceeds 105°C.	During compressor operation	Automatically restarts after safety time (170 seconds)	4 times	Yes	Yes
5	AC overcurrent	Lowers the operating frequency if the compressor AC current exceeds set valve(*). Show "2-2(1)AC peak control" Stops the compressor if the current exceeds at 40Hz or less set valve(*).	During compressor operation	Automatically restarts after safety time (170 seconds)	4 times	Yes	Yes
6	Compressor lock	Stops the compressor if the compressor AC current exceeds (AE-X08BE: 3.2A, except AE-X08BE:2.7A) immediately after activating the compressor (in 6 seconds).	Immediately after compressor activation.	Automatically restarts after safety time (170 seconds)	4 times	Yes	Yes

(*)

Model	Set valve	
	Cool	Heat
AE-X08BE	7.0A	6.5A
AE-X10BE	7.0A	8.5A
AE-X13BE	7.9A	10.5A
AU-X08BE	6.0A	—
AU-X10BE	6.5A	—
AU-X13BE	7.9A	—

NO	Function	Operation				Self diagnostic display	
		Description	Detection time	Restart condition	Restart times	Indoor	Outdoor
7	Compressor overheating control	Lowens the operating frequency if the temperature of the compressor chamber thermistor (TH1) rises above 105°C or 101°C. Stops the compressor if the thermistor stays above 105°C or 101°C for 1 minutes at minimum frequency or less.	During compressor operation	Automatically restarts after safety time (170 seconds)	No limit	No	No
8	Compressor high temperature error	Stops the compressor if the compressor chamber thermistor is above 114°C. (Or when TH1 shorts)	During operation	Automatically restarts when thermistor (TH1) temperature falls below 100°C (approximately 30 minutes)	4 times	Yes	Yes
9	Outdoor heat exchanger overheating control	Lowens the operating frequency if the temperature of the outdoor heat exchanger rises above 56°C during cooling. Stops the compressor if the temperature stays above 56°C for 1 minute at mininum frequency.	During compressor operation	Automatically restarts after safety time (170 seconds)	No limit	No	No
10	Outdoor thermistor short	Stops the compressor if an outdoor thermistor (excluding TH1) shorts.	When compressor is activated	Automatically restarts after safety time (170 seconds)	4 times	Yes	Yes
11	Outdoor thermistor open	Stops the compressor if the circuit of an outdoor thermistor breaks.	When compressor is activated	Automatically restarts after safety time (170 seconds)	4 times	Yes	Yes
12	AC abnormal current error	Stops the compressor if if the operating frequency is above 70 Hz and the compressor current is below 1.0 A.	During compressor operation	Automatically restarts after safety time (170 seconds)	4 times	Yes	Yes
13	Serial signal error	Turns the compressor relay off if the indoor unit does not receive a serial signal from the outdoor unit for 8 minutes.	During operation	Automatically restarts less than 8 minutes after operation stops	No limit	Yes	—
		Stops the compressor if the outdoor unit does not receive a serial signal from the indoor unit for 30 seconds.	During operation	Restarts after reception of serial signal	No limit	—	Yes
14	Power factor module (Active filter) error	When an power factor module error input is detected.	During compressor operation	Automatically restarts after safety time (170 seconds)	4 times	Yes	Yes

BREAK DOWN DIAGNOSIS PROCEDURE

Self-diagnostic procedure using display mode
 If the timer lamp blinks during operation, the problem can be diagnosed using the following table.

● : Blinks at 2-second intervals × : OFF ○ : ON ◎ : Blinks 3 times at 0.2-second intervals

Condition of indoor and outdoor unit	Display by indoor unit operation lamp							Display by outdoor unit lamp LED 1	Diagnosis	What to check, procedure	Solution
	Displayed in a pattern which comes on at the same time as the timer lamp 										
Normal	×	×	×	×	×	×	×	●	Normal	Does compressor active ? Does it go off immediately after active ?	1. Apply an external shock to the compressor. 2. Replace the compressor.
Indoor and outdoor unit completely stopped	×	×	○	×	×	×	×	◎	Compressor lock error	1. Is the discharge outlet of the outdoor unit clogged ? 2. Is the power supply voltage at least 198 V at full power operation ? 3. Check for refrigerant leaks at the tubing connections. 4. Measure the resistance of compressor thermistor TH1 on the outdoor unit (see Figure 2). 5. Measure the resistance of heat exchanger pipe thermistor TH2 on the indoor unit (see Figure 1).	1. Clear the discharge outlet. 2. Assure power supply voltage. 3. Refill to rated amount. 4. Replace the outdoor thermistor assembly. 5. Replace the indoor control board assembly or only TH2.
	×	×	○	○	○	×	×	◎	DC overcurrent error	1. Check the circuit in the power transistor module. 2. Is the outdoor fan revolving ?	1. Replace power transistor module
	×	×	×	×	×	○	○	◎	Short circuit of the thermistor error	1. Measure the resistance of thermistor TH2 on the outdoor unit (see Figure 2).	1. Replace the outdoor thermistor assembly.
	×	×	○	○	×	○	○	◎	Open circuit of the thermistor error	1. Are the connectors of the outdoor unit thermistors well attached ? 2. Measure the resistance of thermistors TH1 and TH2 on the outdoor unit (see Figure 2).	1. Reattach. 2. Replace the outdoor thermistor assembly.
	×	×	×	×	○	○	○	◎	AC abnormal current error	1. Can voltage be detected at the current transformer on the outdoor unit control board?	1. Replace the outdoor control board assembly (Current transformer wire break.)
	×	×	○	○	○	○	×	◎	AC overcurrent error	1. Is the discharge outlet of the outdoor unit clogged ?	1. Clear the discharge outlet.
	○	×	×	×	○	○	○	×	Power factor module error	1. Check wiring of power factor module.	1. Replace the power factor module.
	○	×	×	×	○	○	○	×	Indoor fan out of order	1. Is the fan motor locked ? 2. Is the wiring connector firmly fitted ? 3. Is the speed signal applied to the motor ?	1. Replace fan motor 2. Reattach. 3. Replace the indoor control board assembly.
	○	×	×	×	○	○	×	○	Serial short	1. Check the wiring between units.	1. Rewire.
	○	×	×	×	×	○	×	×	Serial open	1. Check the wiring between units.	1. Rewire.
Indoor unit operating	○	×	×	×	×	○	×	○	Outdoor power supply doesn't turn on. Wiring mistake.	1. Check the fuse in the outdoor unit. 3. Indoor control board. 4. Outdoor control board.	1. Replace the fuse, replace the outdoor board assembly. 3. Replace the board. 4. Replace the board.

Note: 1. Normal : Only the timer lamp blinks. Error : Displayed by blinking of run lamp (above table).
 2. "OFF", the self-diagnostic memory will be erased.
 3. Example of outdoor unit LED 1 blinking :

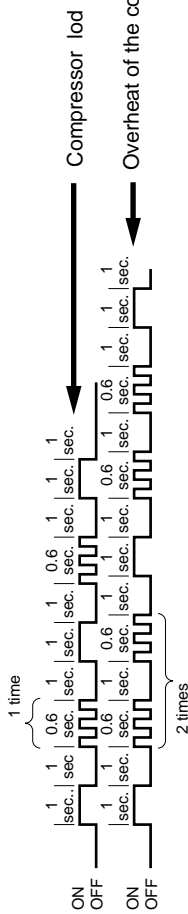

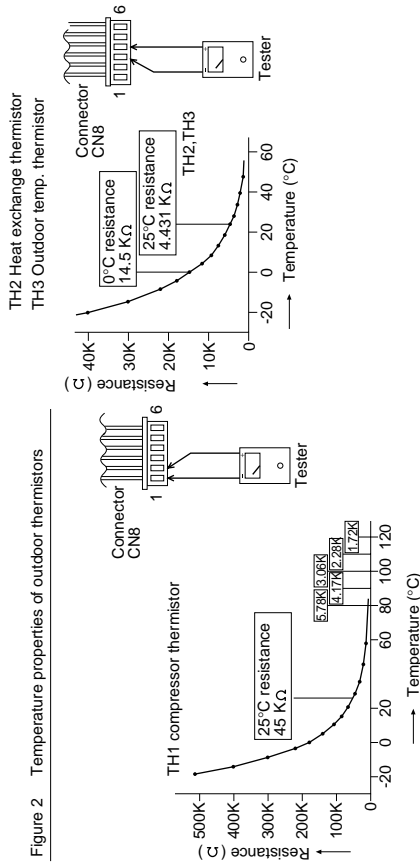

Figure 2 Temperature properties of outdoor thermistors

To measure the resistance, first remove the connector from the board.

Thermistor	No.	Connector	Color
Compressor thermistor	TH1	No. 1 to 2	Red
Heat exchanger pipe thermistor	TH2	No. 3 to 4	Orange
Outdoor temp. thermistor	TH3	No. 5 to 6	Green

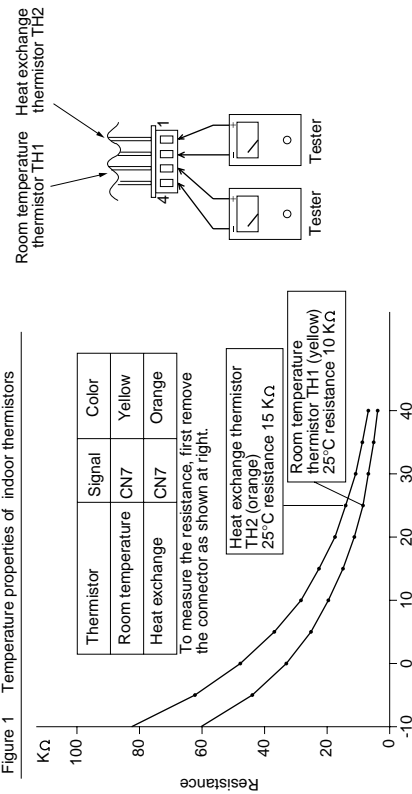
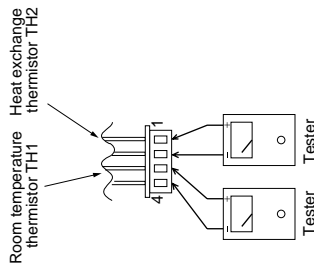
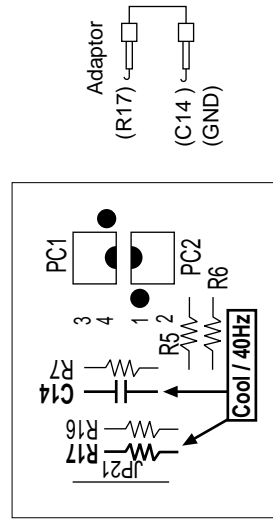

Figure 1 Temperature properties of indoor thermistors



Cautions when attaching or removing the board

When operating only the outdoor unit (cooling 40 Hz fixed mode) To make only the outdoor unit run in cooling mode, short the places marked with arrows below with an adaptor, and apply a voltage of 220 ~ 240 V AC to 1 and N on the terminal board.
 (Avoid operating the outdoor unit alone for long periods of time.)



Microcomputer terminal	Input signal
Pin No. 43	0 Low input
Pin No. 42	1 High input

To Outdoor control board

REFRIGERATION CYCLE

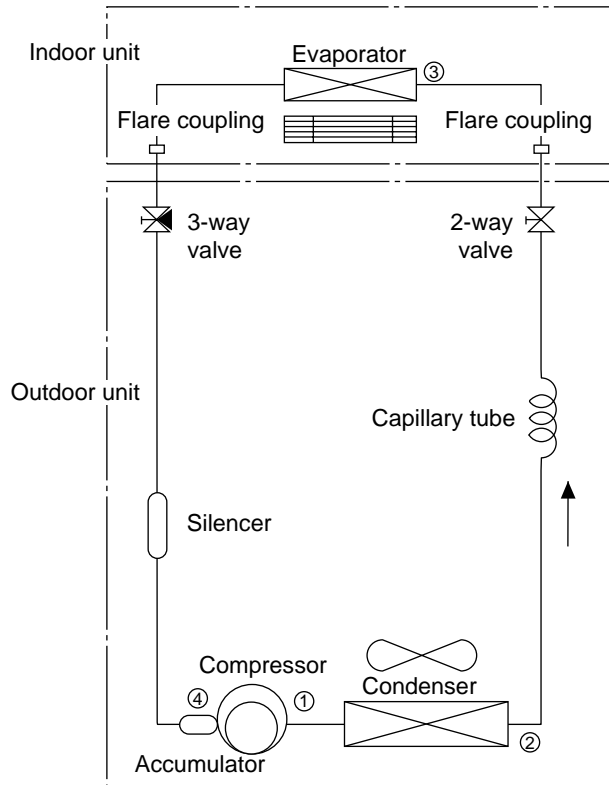

Figure R-1. Refrigeration Cycle for AH-X08BE/10BE/13BE

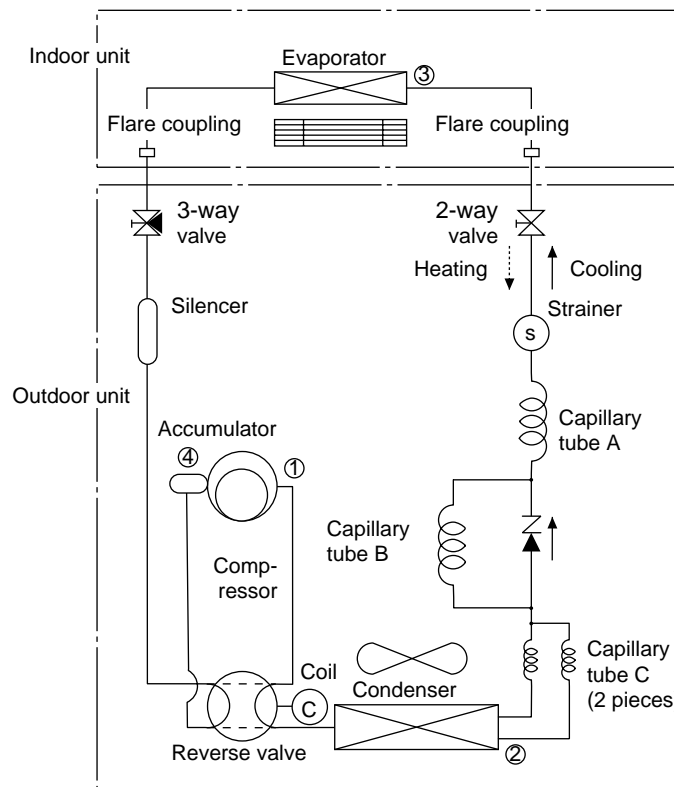

Figure R-2. Refrigeration Cycle for AY-X08BE/10BE/13BE

**Standard conditions:
AH-X08BE / AH-X10BE / AH-X13BE**

	Indoor side		Outdoor side	
	Dry-bulb Temp. (°C)	Relative Humidity (%)	Dry-bulb Temp. (°C)	Relative Humidity (%)
Cooling	27	47	35	40

Temperature at each part and pressure in 3-way valve

Model	AH-X08BE		AH-X10BE		AH-X13BE	
Operation mode	Cool (Max.)	Cool	Cool (Max.)	Cool	Cool (Max.)	Cool
No. / Hz	84	50 settle	101	50 settle	95	50 settle
①	90°C	70°C	97°C	70°C	100°C	73°C
②	40°C	41°C	40°C	42°C	40°C	45°C
③	11°C	13°C	13°C	14°C	13°C	14°C
④	5°C	8°C	10°C	10°C	12°C	11°C
3-way valve pressure (MPaG)	0.44	0.55	0.45	0.63	0.46	0.60

Dimension of Capillary tube

	AH-X08BE			AH-X10BE			AH-X13BE		
Model	O.D	I.D	L	O.D	I.D	L	O.D	I.D	L
Capillary tube	ø2.7	ø1.4	500	ø2.7	ø1.5	600	ø2.7	ø1.6	500

**Standard conditions:
AY-X08BE / AY-X10BE / AY-X13BE**

	Indoor side		Outdoor side	
	Dry-bulb Temp. (°C)	Relative Humidity (%)	Dry-bulb Temp. (°C)	Relative Humidity (%)
Cooling	27	47	35	40
Heating	20	—	7	87

Temperature at each part and pressure in 3-way valve

Model	AY-X08BE				AY-X10BE				AY-X13BE			
Operation mode	Cool (Max.)	Heat (Max.)	Cool	Heat	Cool (Max.)	Heat (Max.)	Cool	Heat	Cool (Max.)	Heat (Max.)	Cool	Heat
No. / Hz	65	more than 67	50 settle	50 settle	78	more than 85	50 settle	50 settle	98	more than 107	50 settle	50 settle
①	99°C	102°C	83°C	74°C	100°C	96°C	72°C	59°C	96°C	100°C	73°C	58°C
②	42°C	0°C	42°C	2°C	43°C	0°C	43°C	2°C	42°C	2°C	41°C	3°C
③	11°C	35°C	13°C	3°C	14°C	31°C	15°C	32°C	13°C	35°C	15°C	31°C
④	16°C	3°C	12°C	1°C	16°C	3°C	10°C	2°C	13°C	3°C	11°C	3°C
3-way valve pressure (MPaG)	0.47	1.79	0.53	1.42	0.49	1.76	0.59	1.28	0.45	1.80	0.64	1.20

Dimension of Capillary tube

	AY-X08BE			AY-X10BE			AY-X13BE		
Model	O.D	I.D	L	O.D	I.D	L	O.D	I.D	L
Capillary tube A	ø2.7	ø1.4	500	ø2.7	ø1.5	600	ø2.7	ø1.6	300
Capillary tube B	ø2.7	ø1.4	400	ø2.7	ø1.5	400	ø2.7	ø1.6	300
Capillary tube C	ø2.7	ø1.6	150	ø2.7	ø1.6	150	ø2.7	ø1.6	150

PERFORMANCE CURVES

- NOTE: 1) Indoor fan speed: Hi
 2) Vertical adjustment louver "45°", Horizontal adjustment louver "front"
 3) Indoor air temp. : Cooling 27°C, Heating 20°C
 (Running frequency: 63HZ)

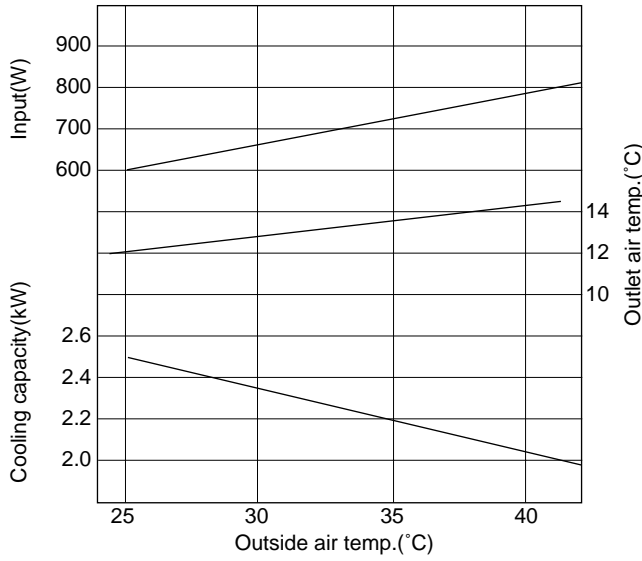

Figure P-1. At Cooling for AH-X08BE

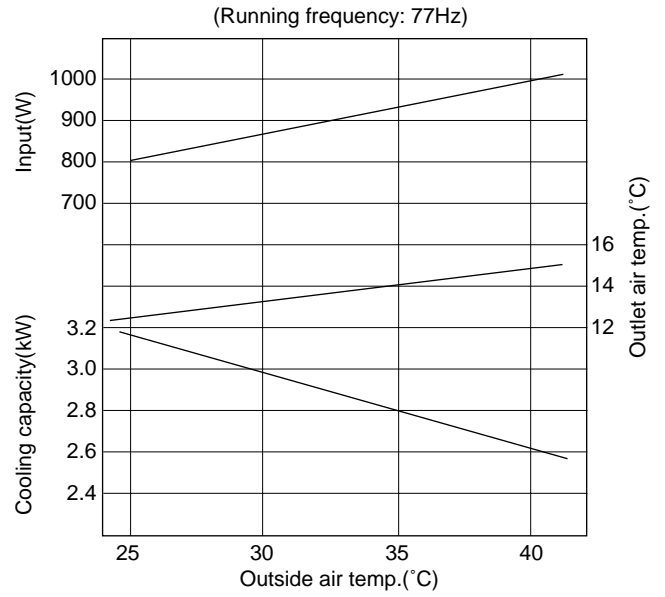

Figure P-2. At Cooling for AH-X10BE

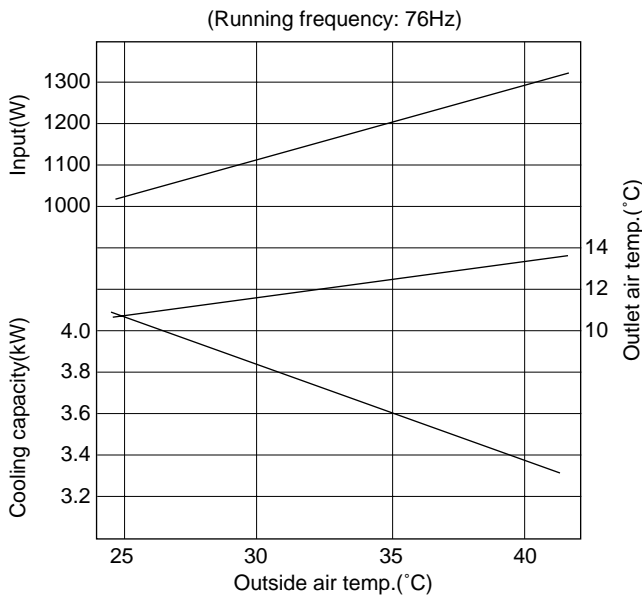

Figure P-3. At Cooling for AH-X13BE

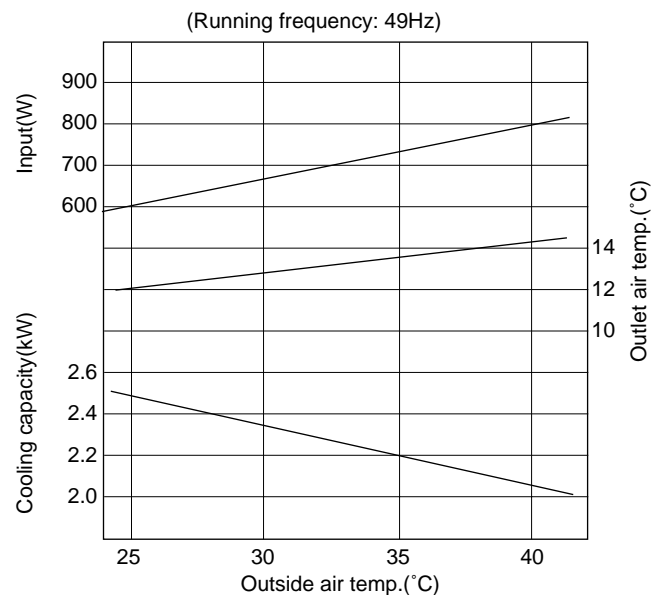

Figure P-4. At Cooling for AY-X08BE

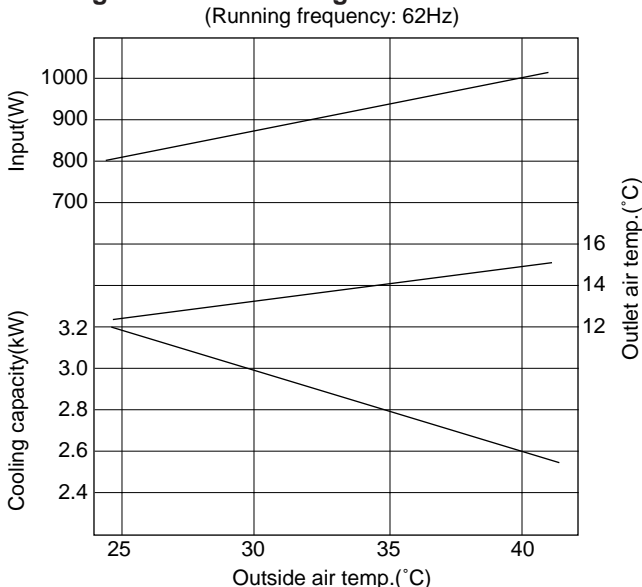

Figure P-5. At Cooling for AY-X10BE

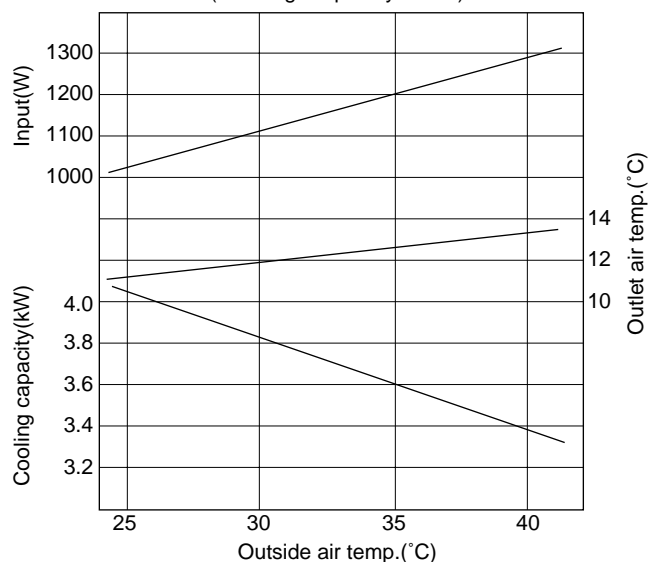

Figure P-6. At Cooling for AY-X13BE

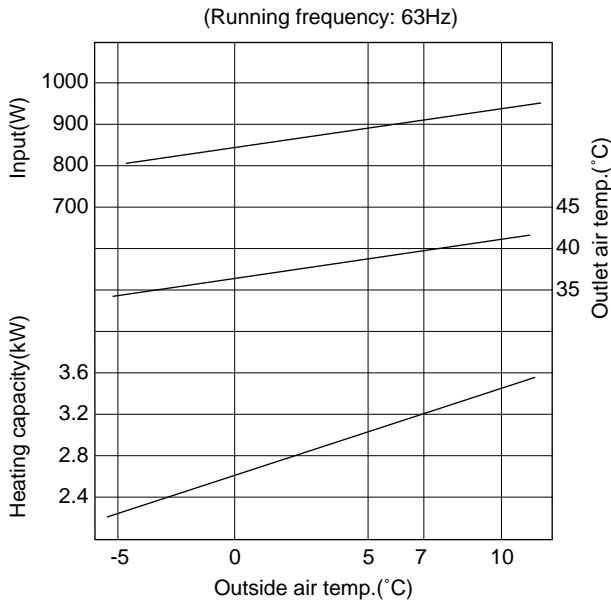

Figure P-7. At Heating for AY-X08BE

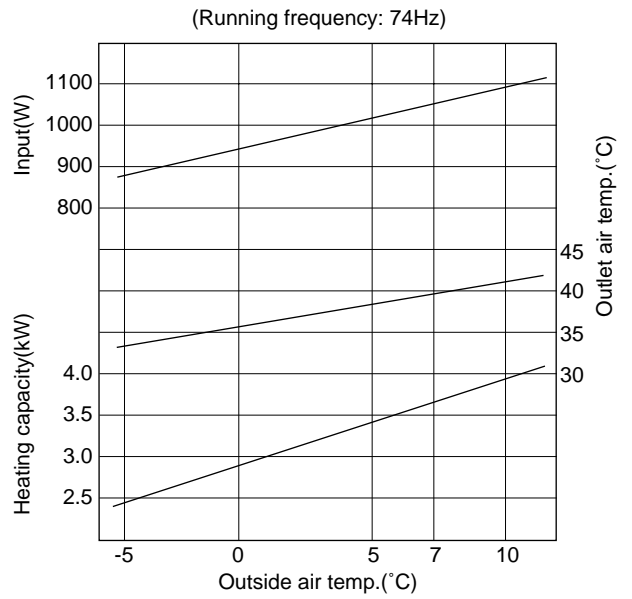

Figure P-8. At Heating for AY-X10BE

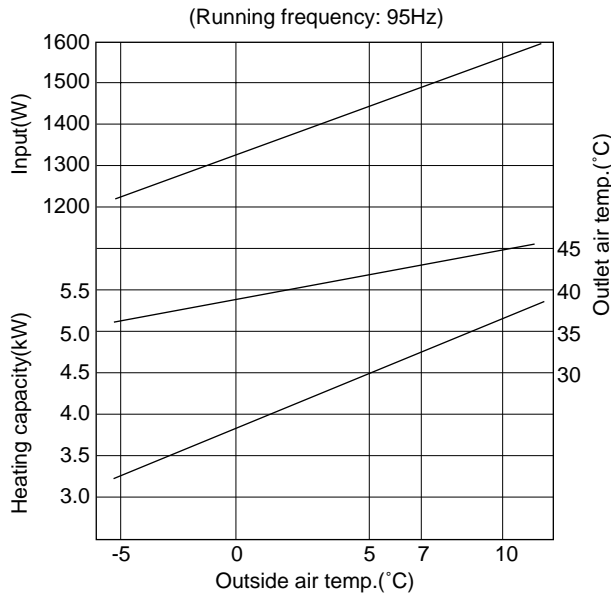
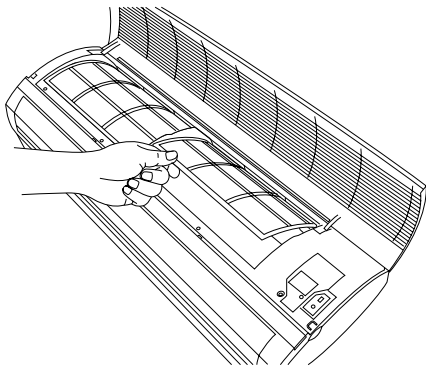
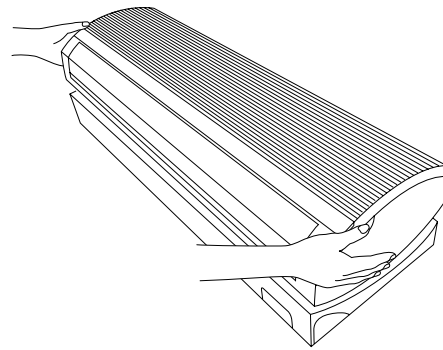

Figure P-9. At Heating for AY-X13BE

DISASSEMBLING PROCEDURE FOR INDOOR UNIT [AY-X08BE/X10BE/X13BE AND AH-X08BE/X10BE/X13BE] CAUTION : DISCONNECT THE UNIT FROM THE POWER SUPPLY BEFORE ANY SERVICING



1. Open the open panel, and remove 2 air filters.



5. Pull the front panel up.

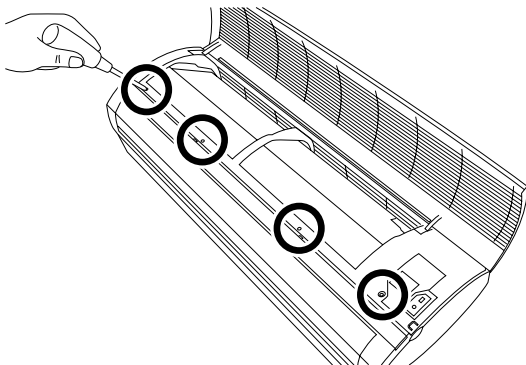

2. Remove 4 screws fixing the front panel.

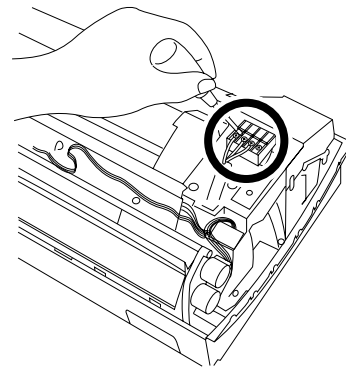

6. Remove the unit-to-unit wiring from the terminal board.

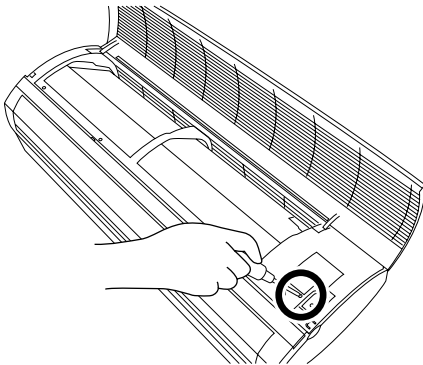

3. Remove the screw fixing the cord clamp.
Note: During reassembly, install the holder after installing the front panel. This will make it easier to assemble the front panel.

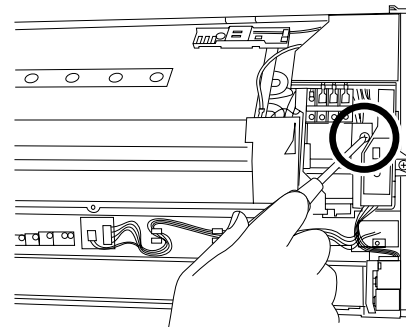

7. Remove a screw fixing the control box cover, and remove it.

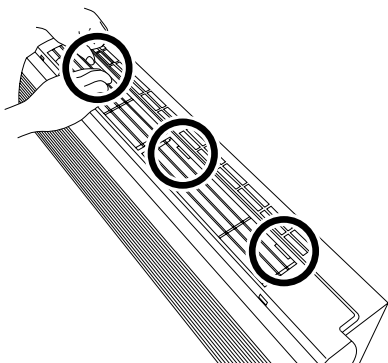

4. Close the open panel. Pushing the nail of the front panel.

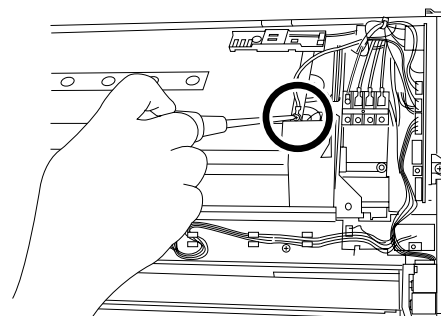

8. Remove a screw fixing the ground wire.
Note: During reassembly, take care for the direction of the lead wire.

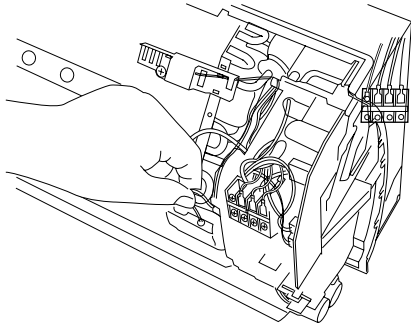

9. Remove the thermistor of the evaporator.

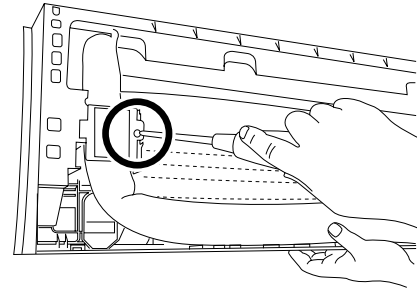

13. Remove the screw fixing the pipe holder.

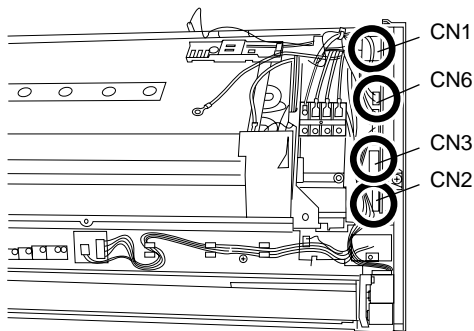

10. Remove 4 connectors.

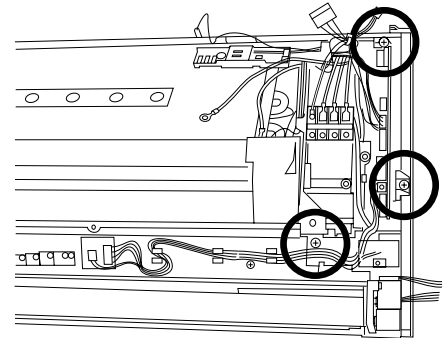

14. Remove 3 screws fixing the control box, and remove the control box.

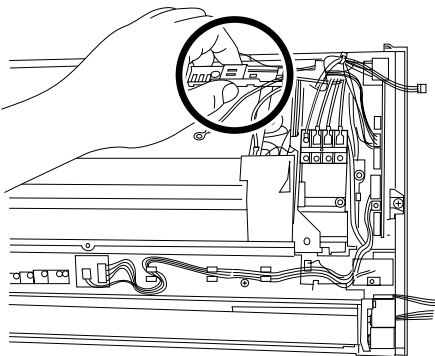

11. Remove the thermistor holder from the evaporator.

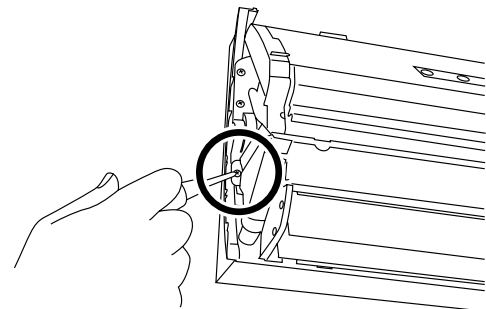

15. Remove a screw fixing the drain pan.

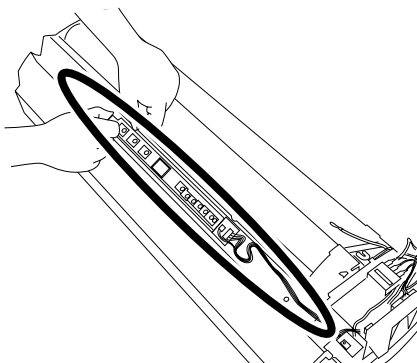

12. Remove the display from the drain pan.

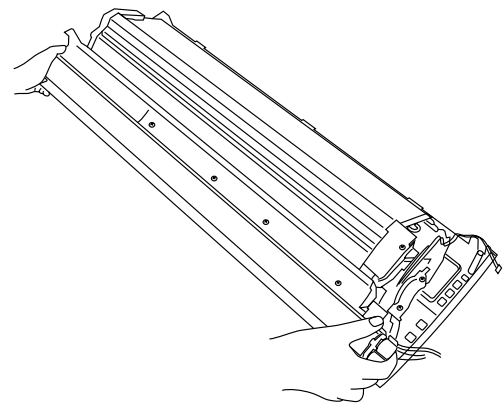

16. Pull drain pan toward you.

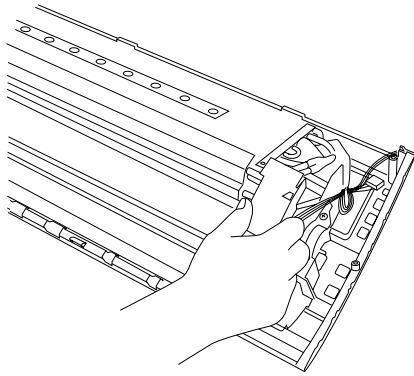

17. Remove the drain cover from the evaporator.
Note: During reassembly, verify that the dew on the pipe is led to the drain pan.

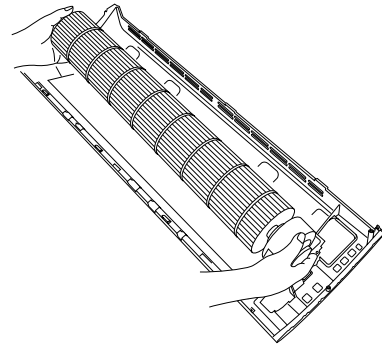
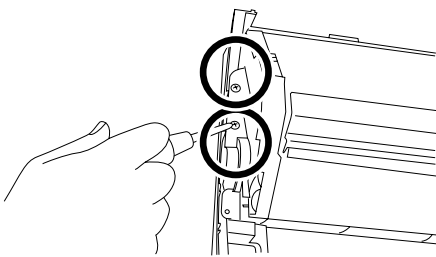
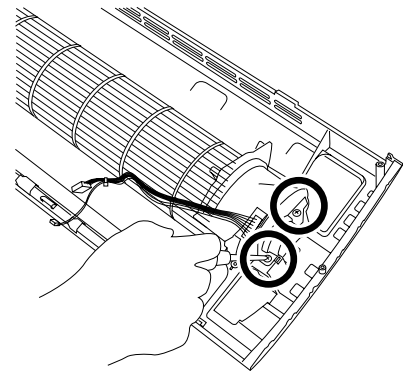

18. Remove 4 screws fixing the evaporator.

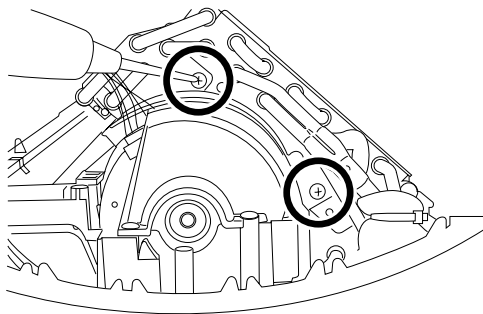

20. Remove 2 screws fixing the motor cover, and pull up the fan.

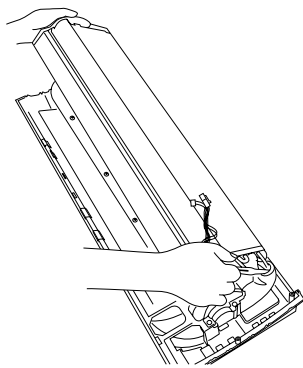
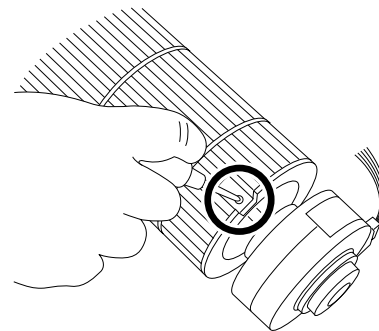

19. Remove the evaporator from the cabinet.

21. Loosen a screw fixing fan.

[Cautionary points for assembling the fan]

- When inserting the motor shaft into the metal fan boss, take care to prevent injuring the inner surface of the metal fan boss.
- Before fastening the motor shaft and fan, insert the motor shaft into contact with the bottom of the metal fan boss.

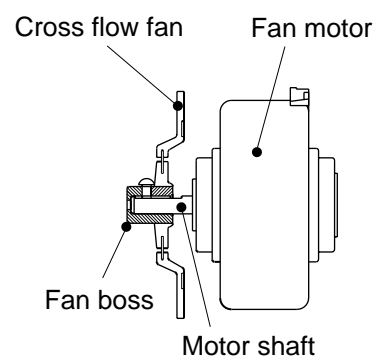

How to remove the display cover

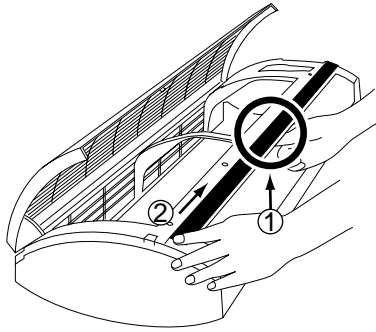

1. Push the center of display cover from the back.
2. Slide the display cover to the right.

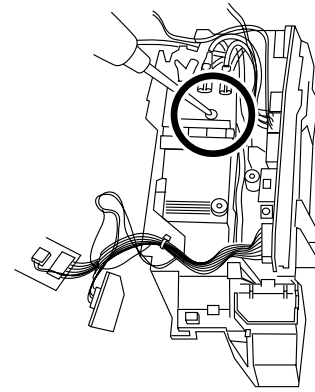

2. Remove the screw fixing the terminal board.

How to assemble the display cover

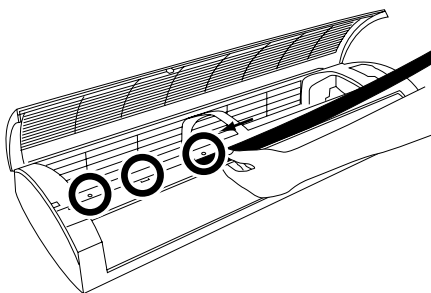

1. Slide the left end of the display cover through 3 hooks on the front panel along the guide from the center of the front panel.

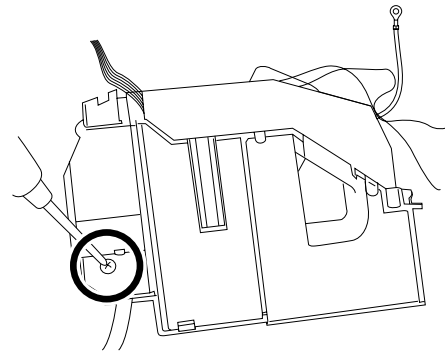

3. Remove a screw fixing the cord holder.

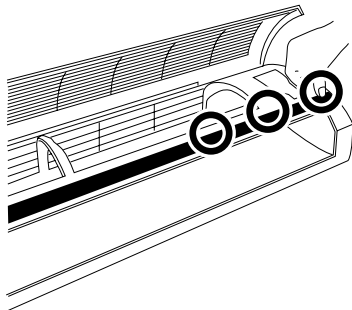

2. After the left half is inserted completely, press the display cover and snap in the 3 hooks on the right.

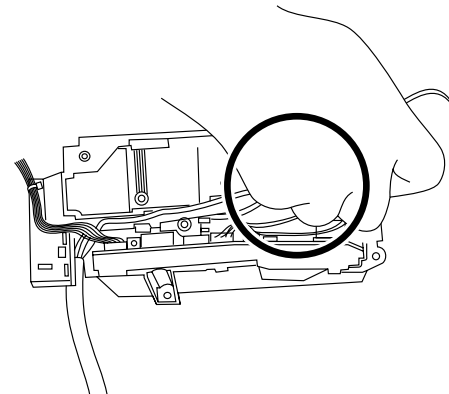

4. Remove 2 screws fixing the board (transformer).

How to remove the control box

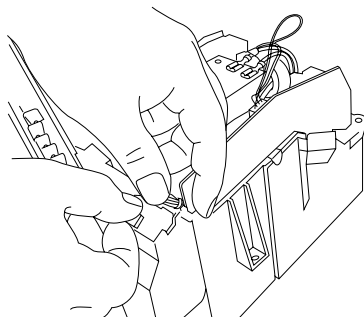

1. Remove the photo detector unit.
 (Press and spread the upper hook, and the photo detector unit will be ready for removal.)

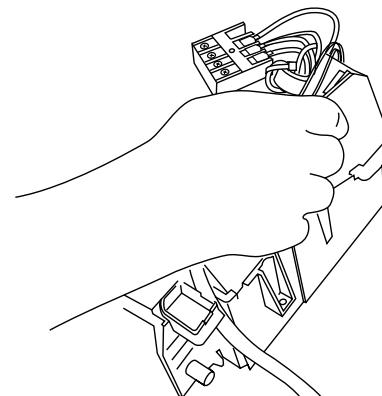

5. Pull the board.

Drain pan and related

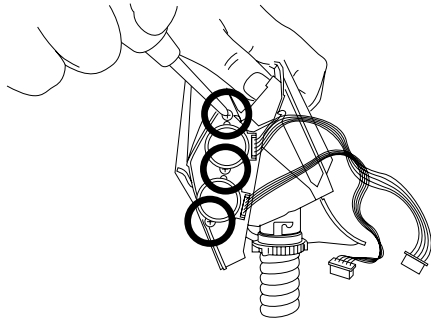

1. Remove 3 screws fixing motors.

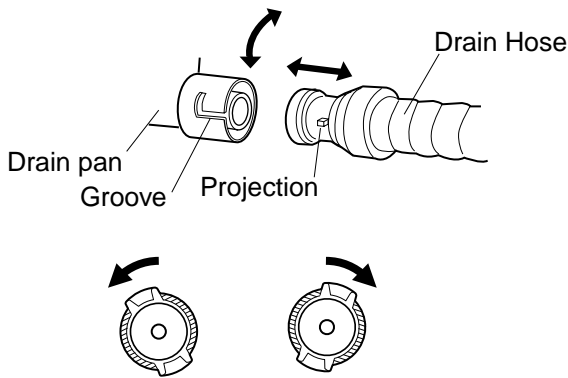

To disconnected To reconnect

2. Turn the cap area of the drain hose counterclockwise, and remove it from the drain pan.
During installation, turn the drain hose to the state of the "engagement position".
After reinstallation, verify that it is securely fastened.

How to remove the horizontal louver

Slightly pull down the hinge area, deflect the louver, and unhook it from the hinge. Remove the shaft from each of the left and right sides.

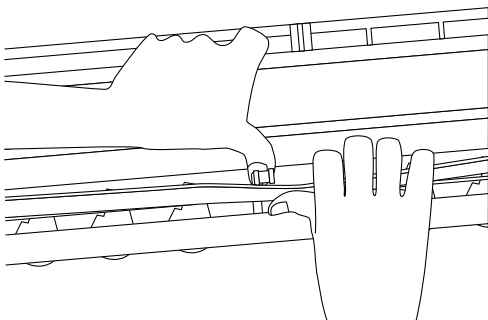

FOR OUTDOOR UNIT [AU-X08BE/X010BE/X13BE, AE-X08BE/X010BE/X13BE]
CAUTION : DISCONNECT THE UNIT FROM THE POWER SUPPLY BEFORE ANY SERVICING

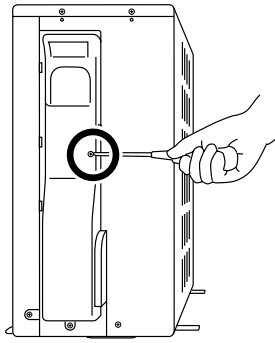

1. Loose a screw fixing the side cover.

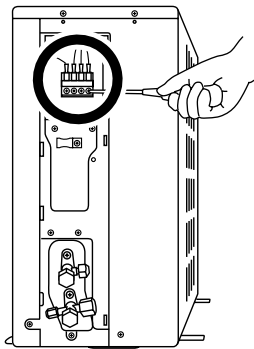
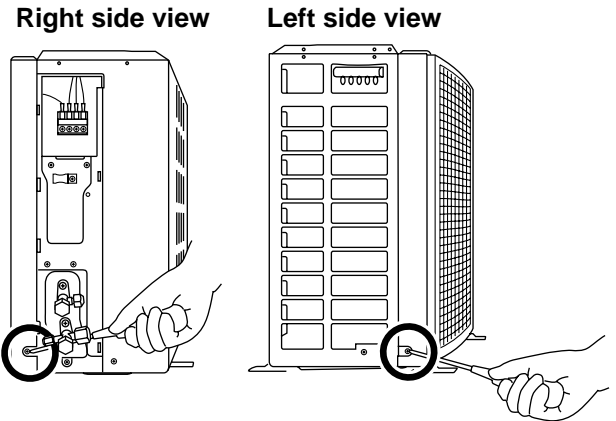

2. Loose the unit to unit cord.

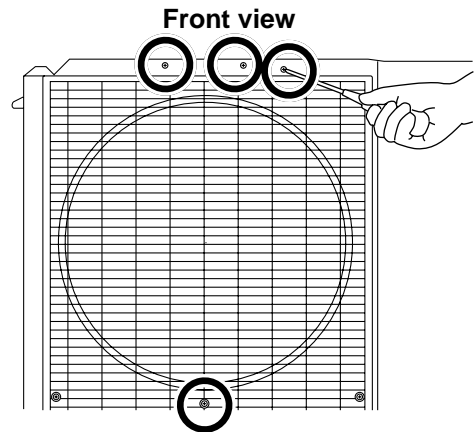

5. Loose 6 screws fixing the front panel.

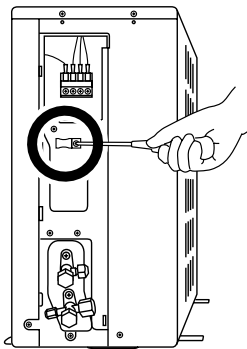

3. Loose a screw fixing the cord clamp.

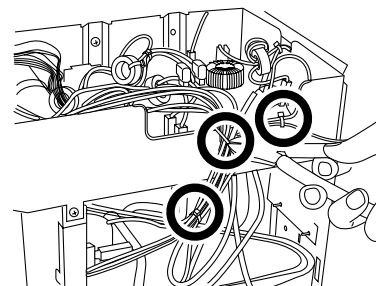

6. Cut 3 nylon bands.

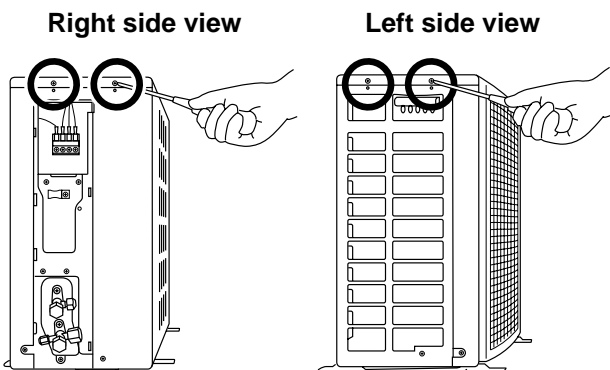

4. Loose 4 screws fixing the top panel.

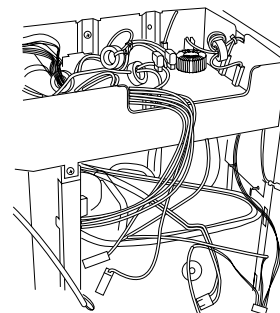

7. Disconnect following connectors and each wire.

- Choke coil (two terminal)
- Fan motor
- Thermistor
- Reverse valve (AE-X08BE/10BE/13BE)

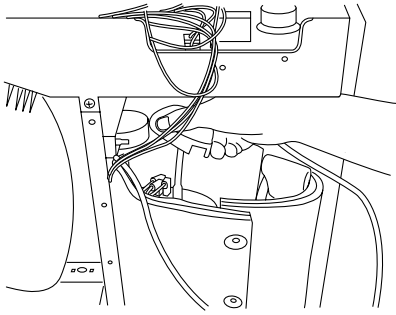

8. Remove the terminal cover of compressor.

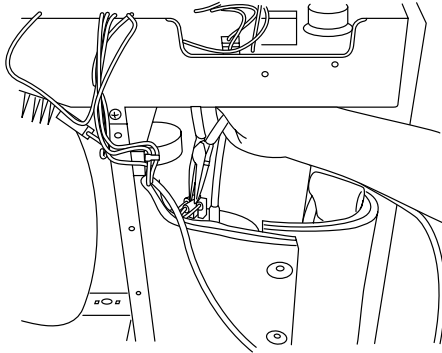

9. Remove 3 terminals of compressor..

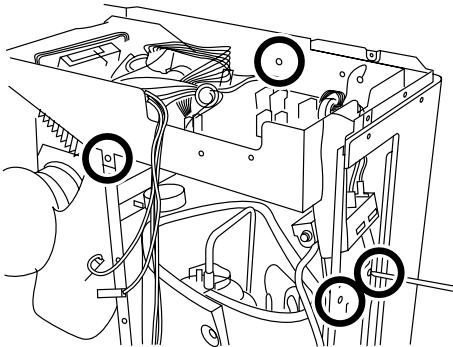

10. Loose 4 screws fixing the control box.

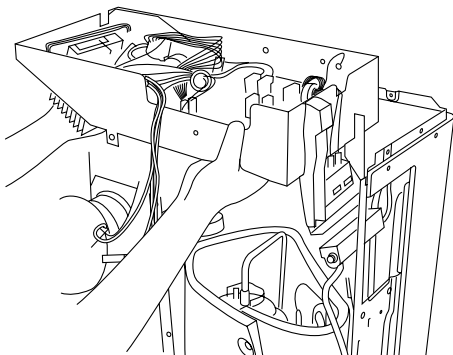

11. Take out the control box.

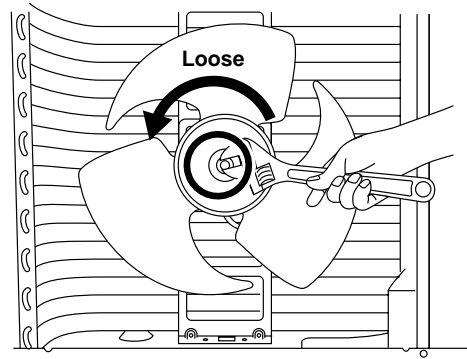

1. Loose the fan nut and fan can take out.

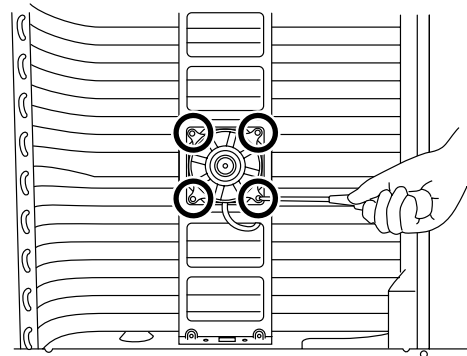

2. Fan motor is secured by 4 screws.

OPTION

HOW TO REPLACE THE AIR PURIFYING FILTER (AZ-F900B; Electrostatic Type (2-sheet package))

Precautions

- The filters are sealed in a plastic bag to keep their dust collection effect. Do not open the bag until using the filters. (Otherwise the filters' life may get shorter.)
- Do not expose the filters to direct sunlight. (Otherwise they may deteriorate.)

1. REMOVE THE AIR FILTERS.

- 1) Open the front panel
- 2) Push the air filter up slightly to unhook them.

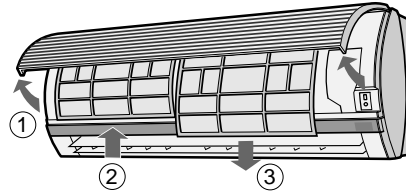

2. CHECK THE AIR PURIFYING FILTERS.

- 1) Take of the old air purifying filters from the air filters. Snap out in the arrow marked direction.
- 2) Set the new air purifying filters with filter stoppers located on the air filters.

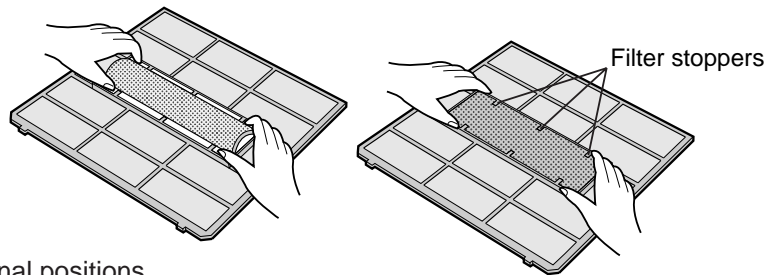

3. REINSTALL THE AIR FILTERS

- 1) Reinstall the air filters in the original positions.
- 2) Close the front panel.
- 3) Push the center part of the panel firmly to lock it in place.

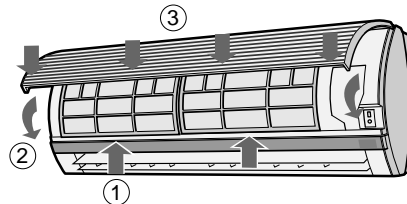

REPLACEMENT INTERVALS GUIDELINE

Replace the air purifying filters at the intervals of 3-6 months.

- The dirty filters are not washable for reuse.
- The filters are available at your nearest dealer.

REPLACEMENT PARTS LIST [AH/AY-X08BE/10BE/13BE]

REF. NO.	PART NO.	DESCRIPTION	Q'TY	CODE
CABINET AND UNIT PARTS				
1- 1	CMOT-A389JBKZ	Fan motor sub assembly	1	BG
1- 2	PGUMSA046JBEO	Damper rubber	1	AD
1- 3	CHLD-A067JBK0	Bearing assembly	1	AL
1- 4	DCHS-A399JBKZ	Cabinet sub assembly [AY-X08BE, AH-X08BE/X10BE]	1	BD
1- 4	DCHS-A401JBKZ	Cabinet sub assembly [AY-X10BE/13BE, AH-X13BE]	1	BC
1- 5	NFANCA089JBEBZ	Cross flow fan	1	BD
1- 6	DSRA-A234JBKZ	Drain pan sub assembly	1	BB
1- 7	CMOTLA901JBEZ	Fan motor	1	BG
1- 8	MJNTPA082JBFA	Louver link	2	AC
1- 9	MLOV-A299JBFA	Vertical louver	12	AC
1-10	MLOV-A297JBFA	Horizontal louver A	1	AK
1-11	MLOV-A298JBFA	Horizontal louver B	1	AK
1-12	QW-VZC406JBEO	Lead wire (for Fan motor)	1	AK
1-13	LHLD-A197JBFP	Louver holder	2	AX
1-14	NBRG-A026JBFA	Louver bushing	2	AB
1-15	LHLD-A476JBFZ	Display cover	1	AK
1-16	PHOS-A025JBEO	Drain hose	1	AL
1-17	PPACGA010JBEO	O ring	1	AB
1-18	PGID-A097JBFZ	Drain cover	2	AF
1-19	RMOT-A061JBEO	Louver motor	2	AS
1-20	PGUMMA110JBEO	Drain plug	1	AD
1-21	CWAK-C101JBKZ	Front panel assembly	1	BL
1-22	PPLT-A212JBFZ	Side cover R	1	AL
1-23	PPLT-A213JBFZ	Side cover L	1	AL
1-24	PCOV-A615JBRA	Display cover	1	BC
1-25	PFILMA145JBEA	Air filter	2	AL
1-26	DHLD-A010JBKZ	Tube holder assembly	1	AK
1-27	HPNL-A514JBFA	Open panel	1	AQ
1-28	TSPC-D601JBRA	Name label [AH-X08BE]	1	AF
1-28	TSPC-D599JBRA	Name label [AH-X10BE]	1	AF
1-28	TSPC-D600JBRA	Name label [AH-X13BE]	1	AE
1-28	TSPC-D598JBRA	Name label [AY-X08BE]	1	AC
1-28	TSPC-D588JBRA	Name label [AY-X10BE]	1	AC
1-28	TSPC-D591JBRA	Name label [AY-X13BE]	1	AC
1-29	PPFFPB901JBEZ	Cabinet insulator [AY-X08BE, AH-X08BE/X10BE]	1	AH
1-30	QW-VZE013JBZZ	Lead wire (upper)	1	AG
1-31	GWAK-A257JBFA	Front panel	1	AX
1-32	PCOV-A614JBFZ	Drain cover	1	AG
1-33	TLABCB374JBRZ	Wiring diagram	1	AC
1-34	QW-VZD893JBZZ	Lead wire (Lower)	1	AG
1-35	LHLD-A303JBFA	Tube cover	1	AD
1-36	PSEL-C125JBEZ	Panel insulator	1	AF
1-37	HDEC-B108JBEZ	Sheet	2	AF
1-38	HDEC-B112JBEZ	Sheet	1	AN
1-39	PSEL-C055JBEZ	Evaporator seal [AY-X10BE/X13BE, AH-X13BE]	1	AC
1-40	PSHE-A126JBEO	Evaporator seal	1	AG
1-41	LSPR-A007JBEO	Seet spring	2	AD
1-42	PSEL-C136JBEZ	Insulator [AY-X10BE/X13BE, AH-X13BE]	1	AC
1-43	PPFFPB962JBEZ	Insulator	1	AC
1-44	PPFFPB967JBEZ	Sidecover insulator	1	AC

CONTROL BOX

2- 1	RTHM-A300JBEO	Thermistor	1	AP
2- 2	PBOX-A342JBFZ	Control box	1	AQ
2- 3	PBOX-A341JBFZ	Terminal cover	1	AH
2- 4	LHLD-A500JBFZ	Thermistor holder	1	AC
2- 5	PCOV-A300JBF0	Thermo holder cover	1	AB
2- 6	HPNLCA776JBFA	Control box cover	1	AG
2- 7	HPNLCA777JBEA	Control panel	1	AD
2- 8	PCOV-A618JBFA	LED holder	1	AE
2- 9	PCOV-A619JBFA	LED holder B	1	AE
2-10	DPWBFA205JBKZ	Control board unit [AH-X08BE]	1	BR
2-10	DPWBFA200JBKZ	Control board unit [AH-X10BE]	1	BR
2-10	DPWBFA201JBKZ	Control board unit [AH-X13BE]	1	BR
2-10	DPWBFA199JBKZ	Control board unit [AY-X08BE]	1	BR
2-10	DPWBFA196JBKZ	Control board unit [AY-X10BE]	1	BR
2-10	DPWBFA197JBKZ	Control board unit [AY-X13BE]	1	BR
2-11	QACC-A158JBEO	Power supply cord	1	AT
2-12	QTANZA002JBZZ	Terminal board (3pin)	1	AN
2-13	QTANZA001JBZZ	Terminal board (4pin)	1	AQ
2-14	PCOV-A609JBWZ	Control box cover	1	AC
2-15	RIC--A025BDE0	IC (IC4, IC5)	2	AE
2-16	VHPGL6ZS27+-6	LED (LED102)	1	AG
2-17	VHPSL326422-6	LED (LED121)	1	AP

REF. NO.	PART NO.	DESCRIPTION	QTY	CODE
2-18	PCOV-A611JBWZ	Control box cover	1	AF
2-19	PCOV-A610JBWZ	Terminal cover	1	AE
2-20	VHLGPIU28RR-1	Photo detector unit (IC201)	1	AK
2-21	QFS-GA027JBE0	Fuse 3A 250V (WPE1)	1	AD
2-22	VHIKID65783-1	IC (IC6)	1	AK
2-23	RIC--A022BDE0	IC (IC3)	1	AE
2-24	VHIBR24C01A-6	IC (IC8)	1	AF
2-25	RH-TZA098JBE0	Transistor (Q1, Q2)	2	AB
2-26	RH-VZA020JBE0	Varistor (CNR1)	1	AE
2-27	RH-VXA002JBZZ	Varistor (NR1)	1	AF
2-28	RH-IZA149JBE0	IC (IC2)	1	AE
2-29	VHPGL6ZE27+-6	LED (LED103 - 111)	9	AG
2-30	RRLYJA078JBE0	Relay (RY1)	1	AP
2-31	RTRN-A287JBZZ	Transformer (TRANS 1)	1	AT
2-32	VHPGL6ZR27+-6	LED (LED101)	1	AF
2-33	VHRPC817X7/1B	Photo coupler (PC1)	1	AD
2-34	VHRPC853H//--6	Photo coupler (PC2)	1	AG
2-35	VHRS201D01/-6	Solid state relay (SSR1)	1	AK
2-36	VHD1SR139-6-1	Diode (D7-D9)	3	AB
2-37	VHD1SR35-4A-1	Diode (D1-D5)	5	AC
2-38	VHEHZ24-2//--1	Zenner diode (ZD1)	1	AB

CYCLE PARTS

3- 1	CPIPCA678JBKZ	Tube assembly [AH-X08BE/10BE, AY-X08BE]	1	BG
3- 1	CPIPCA679JBKZ	Tube assembly [AH-X13BE, AY-X13BE]	1	BH
3- 1	CPIPCA690JBKZ	Tube assembly [AY-X10BE]	1	BH
3- 2	PSEN-A004JBK0	Flare nut assembly (1/4")	1	AE
3- 3	PSEN-A005JBK0	Flare nut assembly (3/8")	1	AG
3- 3	PSEN-A016JBK0	Flare nut assembly (1/2")	1	AR
3- 4	PVLV-0341JBE0	Flare union (1/4")	1	AG
3- 5	PVLV-0342JBE0	Flare union (3/8")	1	AH
3- 5	PVLV-0406JBE0	Flare union (1/2")	1	AK
3- 6	DEVA-A128JBKZ	Evaporator sub assembly [AY-X10BE]	1	BT
3- 6	DEVA-A123JBKZ	Evaporator sub assembly [AH-X08BE]	1	BR
3- 6	DEVA-A122JBKZ	Evaporator sub assembly [AH-X13BE/AY-X13BE]	1	BT
3- 6	DEVA-A121JBKZ	Evaporator sub assembly [AH-X10BE/AY-X08BE]	1	BS

ACCESSORY PARTS

4- 1	CRMC-A529JBEZ	Remote control [AH-X08BE/X10BE/X13BE]	1	BD
4- 1	CRMC-A528JBEZ	Remote control [AY-X08BE/X10BE/X13BE]	1	BB
4- 2	UBATUA027JBE0	Battery pack	1	AE
4- 3	LHLD-A477JBFA	Cord holder (for covering the terminal board of indoor unit)	1	AE
4- 4	XTTSD40P16000	Tapping screw (for fixing the cord holder)	1	AA
4- 5	LX-NZA207JBEZ	Special nut (for fixing long screw steadily)	9	AE
4- 6	LPFT-A029JBF0	Drain joint [AY-X08BE/X10BE/X13BE]	1	AD
4- 7	PPLTNA058JBWZ	Mounting angle	1	AS
4- 8	XTTSD45P30000	Long screw	8	AA
4- 9	TINSEA262JBRZ	Operation manual	1	AM
4-10	TINS-A664JBRZ	Installation manual	1	AE
4-11	TINS-A665JBRZ	Installation manual	1	AE
4-12	LX-BZA106JBE0	Special screw (for hanging remote controller)	1	AE

SCREWS

5- 1	LX-BZA075JBE0	Special screw (for earth)	1	AA
------	---------------	---------------------------	---	----

PACKING PARTS

6- 1	CPADBA038JBKZ	Packing pad assembly	2	AK
6- 2	SPAKCA745JBEZ	Packing case [AH-X08BE]	1	AR
6- 2	SPAKCA743JBEZ	Packing case [AH-X10BE]	1	AR
6- 2	SPAKCA744JBEZ	Packing case [AH-X13BE]	1	AR
6- 2	SPAKCA742JBEZ	Packing case [AY-X08BE]	1	AR
6- 2	SPAKCA740JBEZ	Packing case [AY-X10BE]	1	AR
6- 2	SPAKCA741JBEZ	Packing case [AY-X13BE]	1	AR

HOW TO ORDER REPLACEMENT PARTS

To have your order filled promptly and correctly, please furnish the following information.

1. MODEL NUMBER
2. REF. NO.
3. PART NO.
4. DESCRIPTION

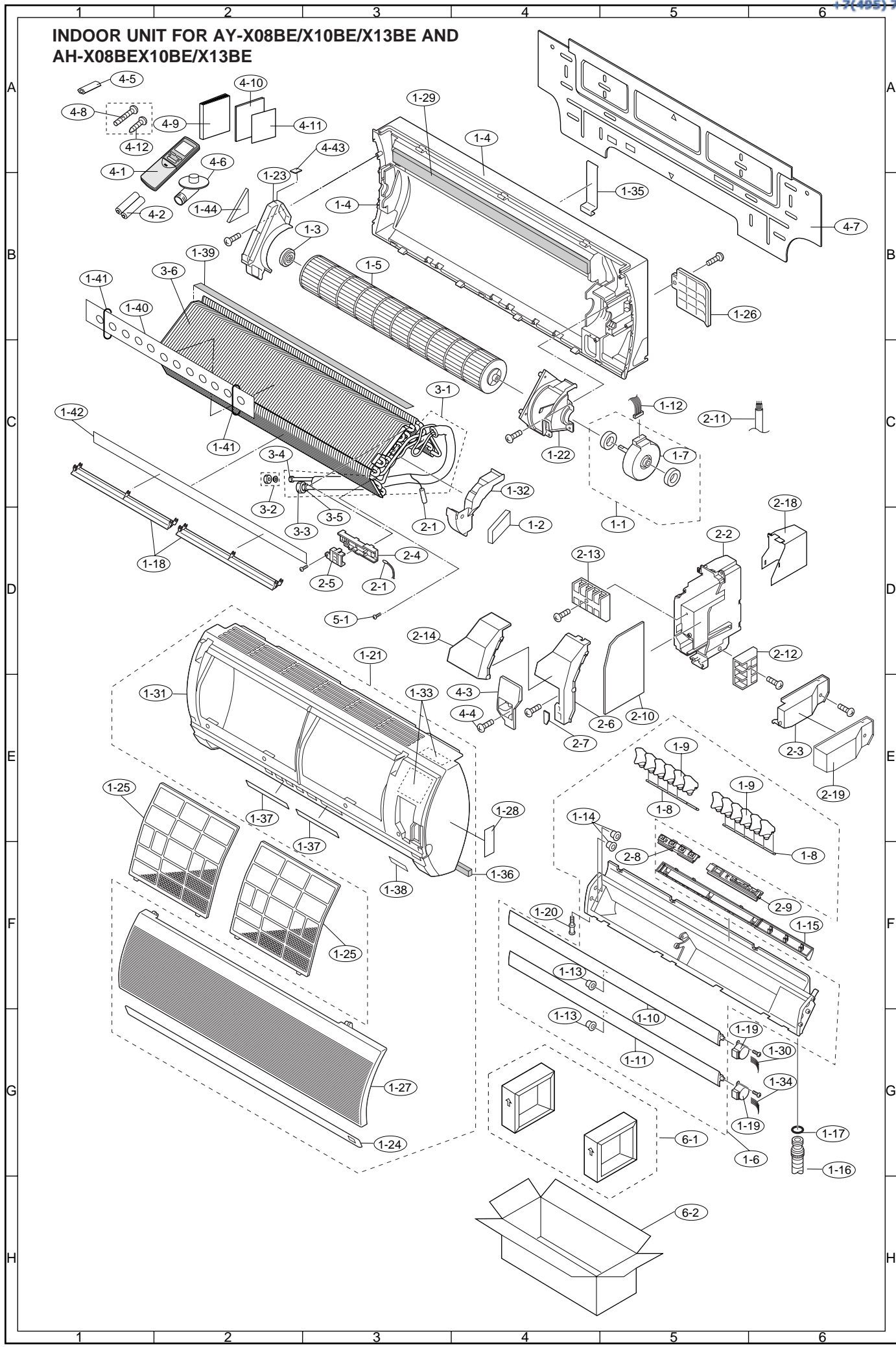

REPLACEMENT PARTS LIST [AU/AE-X08BE/10BE/13BE]

REF. NO.	PART NO.	DESCRIPTION	Q'TY	CODE
CONTROL BOX PARTS				
1- 1	CMOTLA902JBZ	Fan motor [AE-X08BE/X10BE, AU-X08BE/X10BE]	1	BK
1- 1	CMOTLA903JBZ	Fan motor [AE-X13BE, AU-X13BE]	1	BL
1- 2	RTRN-A256JBZ	Current transfoemer CT1	1	AG
1- 3	RFIL-A100JBZZ	Coil assembly [AE-X08BE/X10BE, AU-X08BE/X10BE]	2	AY
1- 3	RFIL-A102JBZZ	Coil assembly [AE-X13BE, AU-X13BE]	2	AV
1- 4	DPWBFA195JBKZ	Electric control board [AE-X08BE/X10BE]	1	BS
1- 4	DPWBFA198JBKZ	Electric control board [AE-X13BE]	1	BG
1- 4	DPWBFA202JBKZ	Electric control board [AU-X08BE/X10BE]	1	BS
1- 4	DPWBFA203JBKZ	Electric control board [AU-X13BE]	1	BS
1- 5	QTANZA001JBZZ	Terminal board (4P)	1	AQ
1- 6	RIC--A022BDE0	Integrated circuit IC2 [AE-X08BE/X10BE, AU-X08BE/X10BE]	1	AE
1- 6	VHIK7818AP1-1	Integrated circuit IC2 [AE-X13BE, AU-X13BE]	1	AF
1- 7	VSKRC245M//-3	Transistor Q3	1	AC
1- 8	VHRPC817X7/1B	Photo coupler PC1	1	AE
1- 8	VHRPC817X7/1B	Photo coupler PC3, PC4 [AE-X13BE, AU-X13BE]	2	AE
1- 9	VHRPC853H//-6	Photo coupler PC2	1	AG
1-10	RC-EZA254JBZZ	Capacitor [AE-X08BE/10BE, AU-X08BE/10BE]	1	BP
1-10	RC-EZA249JBZZ	Capacitor [AE-X13BE, AU-X13BE]	1	BP
1-11	RH-DZA117JBE0	Diode bridge [AE-X08BE/10BE, AU-X08BE/10BE]	1	AM
1-11	RH-DZA087JBE0	Diode bridge [AE-X13BE, AU-X13BE]	1	AQ
1-12	RH-HZ0011JBE0	PTC thermistor	1	AN
1-13	RH-TZA145JBE0	Power transistor module(IPM)[AE-X08BE/10BE, AU-X08BE/10BE]	1	BU
1-13	VHITM38++++-1	Power transistor module(IPM)[AE-X13BE, AU-X13BE]	1	BY
1-14	PDAI-A126JBWZ	Terminal plate	1	AE
1-15	VHITM-05C//-6	Active filter [AE-X08BE/X10BE, AU-X08BE/X10BE]	1	BP
1-15	RH-TXA003JBZZ	Active filter [AE-X13BE, AU-X13BE]	1	BS
1-16	RTHM-A022JBE0	Compressor thermistor	1	AN
1-17	RH-HXA010JBZZ	Thermistor	1	AX
1-18	RTRN-A199JBE0	Choke coil [AE-X08BE/X10BE, AU-X08BE/X10BE]	1	BE
1-18	RTRN-A286JBZ	Choke coil [AE-X13BE, AU-X13BE]	1	BF
1-19	PBOX-A343JBWZ	Control box	1	AR
1-20	LBND-A042JBE0	Wire fixing band	4	AC
1-21	PSPA-A151JBZZ	Spacer	5	AE
1-22	LHLD-A479JBFZ	Heat sink holder	1	AE
1-23	PRDAFA140JBZ	Heat sink for powertransistor module[AE-X08BE/10BE, AU-X08BE/10BE]	1	AX
1-23	PRDAFA142JBZ	Heat sink for powertransistor module [AE-X13BE, AU-X13BE]	1	AX
1-24	QW-VZD962JBZZ	Lead wire (CN14-QM1) [AE-X13BE, AU-X13BE]	1	AE
1-25	PSHE-A190JBZ	Protect sheet	1	AL
1-26	PSEL-C061JBZ	Insulator	1	AE
1-27	PSPA-A144JBE0	Spacer	5	AC
1-28	RFIL-A064JBE0	Ferrite core	4	AF
1-29	QW-VZD961JBZZ	Lead wire (CN13-AF1) [AE-X13BE, AU-X13BE]	1	AG
1-30	QW-VZD871JBZZ	Lead wire (L1+, L1-)	2	AG
1-31	QW-VZD857JBZZ	Lead wire (Earth)	1	AC
1-32	QW-VZD868JBZZ	Lead wire (MRY1 - DB1)	1	AG
1-33	QW-VZD861JBZZ	Lead wire (MRY1 - PTC)	1	AF
1-34	QW-VZD958JBZZ	Lead wire (DB1+-AF(I+))	1	AK
1-35	QW-VZD866JBZZ	Lead wire (T3 - TB2)	1	AF
1-36	QW-VZD873JBZZ	Lead wire (T10 - IPM(-))	1	AF
1-37	QW-VZD867JBZZ	Lead wire (T5 - DB1))	1	AG
1-38	QW-VZD864JBZZ	Lead wire (T2 - TBN)	1	AF
1-39	QW-VZD865JBZZ	Lead wire (T1 - TB1)	1	AF
1-40	QW-VZD859JBZZ	Lead wire (C8(+)- T7)	1	AE
1-41	QW-VZD870JBZZ	Lead wire (C8(+)- AF(0+))[AE-X08BE/X10BE, AU-X08BE/X10BE]	1	AG
1-42	QW-VZD960JBZZ	Lead wire (C8-AF) [AE-X13BE, AU-X13BE]	1	AL
1-43	QW-VZD869JBZZ	Lead wire (C8(-)- AF(0-))[AE-X08BE/X10BE, AU-X08BE/X10BE]	1	AF
1-44	QW-VZD860JBZZ	Lead wire (C8(-)- T8)	1	AE
1-45	QW-VZD872JBZZ	Lead wire (T9 - IPM(+))	1	AE
1-46	QW-IZA007JBZZ	Lead wire (Compressor wire) [AE-X08BE/X10BE]	1	AP
1-46	QW-IZA017JBZZ	Lead wire (Compressor wire) [AU-X08BE/X10BE]	1	AP
1-46	QW-IZA019JBZZ	Lead wire (Compressor wire) [AE-X13BE, AU-X13BE]	1	AP
1-47	QW-VZD420JBE0	Lead wire (AF lead wire 4P)	1	AE
1-48	RH-IXA660JBZZ	Microcomputer IC1	1	AX
1-49	RH-IZA140JBE0	Integrated circuit IC3	1	AE
1-50	RH-TZA098JBE0	Transistor Q1, Q2	2	AB
1-51	RH-VZA020JBE0	Varistor CNR1, CNR2	2	AB
1-52	RH-VXA002JBZZ	Varistor NR1, NR2	2	AD
1-53	RH-VZA042JBE0	Surge absorber SA1	1	AH
1-54	LBNDKA098JBWZ	Capacitor clamp [AE-X08BE/10BE, AU-X08BE/10BE]	1	AP
1-54	LBNDKA099JBWZ	Capacitor clamp [AE-X13BE, AU-X13BE]	1	AS
1-55	PSEL-C122JBZ	Insulator	1	AC
1-56	PSEL-C123JBZ	Insulator	1	AC
1-57	PSEL-C124JBZ	Insulator	1	AC

REF. NO.	PART NO.	DESCRIPTION	Q'TY	CODE
CABINET AND UNIT PARTS				
2- 1	LANGKA124JBPZ	Fan motor angle	1	AR
2- 2	LANGKA127JBPZ	Fan motor angle sub [AE-X08BE/X10BE, AU-X13BE]	1	AE
2- 2	LANGKA128JBPZ	Fan motor angle sub [AU-X08BE/X10BE]	1	AG
2- 2	LANGKA123JBPZ	Fan motor angle sub [AE-X13BE]	1	AE
2- 3	GCAB-A196JBTA	Rear cabinet	1	BD
2- 3	GCAB-A203JBTA	Rear cabinet [AU-X13BE]	1	BC
2- 4	LHLD-0261JBM0	Cord holder	1	AB
2- 5	PFPPB911JBEZ	Motor angle cushion	1	AC
2- 6	GCAB-A195JBTA	Front panel	1	BC
2- 7	GGADFA037JBFA	Fan guard	1	AT
2- 8	PSEL-C045JBEZ	Motor angle cushion	1	AB
2- 9	PSEL-C048JBEZ	F panel insulator	1	AC
2-10	PSEL-C049JBEZ	F panel insulator	1	AC
2-11	PSEL-C050JBEZ	Bulkhead insulator	1	AG
2-12	TLABBA148JBRA	Sharp badge	1	AH
2-13	CCHS-A735JBTA	Base pan assembly [AE-X08BE/X10BE/X13BE, AU-X13BE]	1	BD
2-13	CCHS-A739JBTA	Base pan assembly [AU-X08BE/X10BE]	1	BD
2-14	PFTA-A092JBFA	Side cover	1	AQ
2-15	PCOV-A616JBPZ	Protect cover	1	AE
2-16	MSPR-A027JBE0	Thermistor spring [AE-X08BE/X10BE, AU-X08BE]	1	AB
2-16	MSPR-A026JBE0	Thermistor spring [AE-X13BE, AU-X08BE/10BE]	1	AB
2-17	MSPR-A046JBE0	Protector spring [AU-X13BE, AE-X08BE/X10BE/X13BE]	1	AC
2-17	MSPR-A066JBE0	Protector spring [AU-X08BE/X10BE]	1	AD
2-18	NFANPA094JBEZ	Propeller fan	1	AX
2-19	PSKR-A223JBWZ	Bulkhead [AU-X08BE/X10BE, AE-X08BE/X10BE]	1	AR
2-19	PSKR-A211JBWZ	Bulkhead [AE-X13BE]	1	AQ
2-19	PSKR-A212JBWZ	Bulkhead [AU-X13BE]	1	AR
2-20	TLABKC757JBRZ	Number card [AU-X08BE]	1	AH
2-20	TLABKC755JBRZ	Number card [AU-X10BE]	1	AH
2-20	TLABKC756JBRZ	Number card [AU-X13BE]	1	AG
2-20	TLABKC754JBRZ	Number card [AE-X08BE]	1	AG
2-20	TLABKC744JBRZ	Number card [AE-X10BE]	1	AG
2-20	TLABKC747JBRZ	Number card [AE-X13BE]	1	AH
2-21	TSPC-D605JBRZ	Name badge [AU-X08BE]	1	AG
2-21	TSPC-D603JBRZ	Name badge [AU-X10BE]	1	AG
2-21	TSPC-D604JBRZ	Name badge [AU-X13BE]	1	AG
2-21	TSPC-D682JBRZ	Name badge [AE-X08BE]	1	AG
2-21	TSPC-D589JBRZ	Name badge [AE-X10BE]	1	AD
2-21	TSPC-D593JBRZ	Name badge [AE-X13BE]	1	AE
2-22	PSEL-C051JBEZ	Side cover seal	1	AE
2-23	FFTA-A014JBKZ	Side cover assembly	1	AT
2-24	TLABCB375JBRZ	Wiring diagram [AE-X08BE/10BE]	1	AC
2-24	TLABCB463JBRZ	Wiring diagram [AU-X08BE/10BE]	1	AE
2-24	TLABCB430JBRZ	Wiring diagram [AE-X13BE, AU-X13BE]	1	AE
2-25	DCAB-A093JBKZ	Top cover assembly [AE-X08BE/X10BE]	1	AY
2-25	DCAB-A107JBKZ	Top cover assembly [AU-X08BE/X10BE]	1	AX
2-25	DCAB-A104JBKZ	Top cover assembly [AE-X13BE, AU-X13BE]	1	AZ
2-26	PSEL-C060JBEZ	Insulator for rear cabinet	1	AB
2-27	GCAB-A197JBTA	Top cover	1	AX
2-28	JHNDPA011JBFA	Holder	1	AS
2-29	PSEL-C046JBEZ	Bulkhead insulator	1	AC
2-29	PSEL-C091JBEZ	Bulkhead insulator [AU-X13BE]	1	AE
2-30	PSEL-C119JBEZ	Box insulator	1	AE
2-31	PSEL-C047JBEZ	Box insulator	1	AF
2-32	PSEL-C062JBEZ	Box insulator	1	AG
2-33	CHLD-A093JBK0	Holder assembly	1	AL
2-34	PSEL-C121JBEZ	Side cover seal	1	AC
2-35	PSEL-C120JBEZ	Side cover seal	1	AC

CYCLE PARTS

3- 1	CVLV-A581JBKZ	Reverse valve assembly [AE-X08BE]	1	BQ
3- 1	CVLV-A572JBKZ	Reverse valve assembly [AE-X10BE]	1	BV
3- 1	CVLV-A574JBKZ	Reverse valve assembly [AE-X13BE]	1	BW
3- 2	DCPY-A218JBKZ	Capillary tube assembly [AE-X08BE]	1	BF
3- 2	DCPY-A212JBKZ	Capillary tube assembly [AE-X10BE]	1	BF
3- 2	DCPY-A217JBKZ	Capillary tube assembly [AE-X13BE]	1	BF
3- 2	DCPY-A221JBKZ	Capillary tube assembly [AU-X08BE]	1	BF
3- 2	DCPY-A219JBKZ	Capillary tube assembly [AU-X10BE]	1	BE
3- 2	DCPY-A220JBKZ	Capillary tube assembly [AU-X13BE]	1	BF
3- 3	PCON-A455JBPZ	Condensor [AE-X08BE/X10BE]	1	BT
3- 3	PCON-A445JBPZ	Condensor [AE-X13BE]	1	BS
3- 3	PCON-A451JBPZ	Condensor [AU-X08BE/X10BE]	1	BS
3- 3	PCON-A449JBPZ	Condensor [AU-X13BE]	1	BT
3- 4	DVLV-A461JBKZ	3 way valve unit [AE-X08BE/X10BE, AU-X08BE/X10BE]	1	AY
3- 4	DVLV-A466JBKZ	3 way valve unit [AE-X13BE, AU-X13BE]	1	BA
3- 5	LX-NZA147JBE0	Service nut [AE-X08BE/X10BE, AU-X08BE/X10BE]	1	AK
3- 5	LX-NZA037JBE0	Service nut [AE-X13BE, AU-X13BE]	1	AG

REF. NO.	PART NO.	DESCRIPTION	Q'TY	CODE
3- 6	LX-NZA146JBE0	Bonnet	2	AF
3- 7	DVLV-A462JBKZ	2 way valve unit	1	AW
3- 8	FCMPRA065JBK0	Compressor ass'y(Including for Ref.No.3-9,3-10,3-11)[AE-X10BE/X13BE,AU-X13BE]	1	CM
3- 8	FCMPRA075JBK0	Compressor ass'y(Including for Ref.No.3-9,3-10,3-11)[AE-X08BE]	1	CH
3- 8	FCMPRA103JBKZ	Compressor ass'y(Including for Ref.No.3-9,3-11~3-14,2-17)[AU-X08BE/10BE]	1	CD
3- 9	PCMPRA267JBE0	Compressor [AE-X10BE/X13BE, AU-X13BE]	1	CK
3- 9	PCMPRA285JBE0	Compressor [AE-X08BE]	1	CK
3- 9	PCMPRA331JBEZ	Compressor [AU-X08BE/10BE]	1	CC
3-10	LBSHCA005JBE0	Terminal bushing [AU-X13BE, AE-X08/X10/X13BE]	1	AA
3-11	PCOV-0562JBE0	Terminal cover [AU-X13BE, AE-X08/X10/X13BE]	1	AD
3-11	PCOV-A010JBE0	Terminal cover [AU-X08/X10BE]	1	AF
3-12	PSEL-A403JBE0	Terminal gasket [AU-X08/X10BE]	1	AB
3-13	PSEL-A150JBE0	Gasket washer [AU-X08/X10BE]	1	AA
3-14	LX-NZA002JBE0	Special nut	1	AA
3-15	GLEG-A001JBE0	Compressor cushion [AU-X08BE/X10BE]	3	AC
3-15	GLEG-A029JBE0	Compressor cushion [AE-X08BE/X10BE/X13BE, AU-X13BE]	3	AE
3-16	PSPF-A767JBEZ	Compressor cover [AE-X08BE/X10BE/X13BE]	1	AV
3-16	PSPF-A780JBEZ	Compressor cover [AU-X08BE/X10BE/X13BE]	1	AT
3-17	PSPF-A768JBEZ	Compressor cover [AE-X08/X10/X13BE]	1	AG
3-17	PSPF-A779JBEZ	Compressor cover [AU-X08/X10/X13BE]	1	AG
3-18	PSEN-A004JBK0	Flare nut ass'y	1	AE
3-19	PSEN-A005JBK0	Flare nut ass'y [AU-X08/X10BE, AE-X08/X10BE]	1	AG
3-19	PSEN-A016JBK0	Flare nut ass'y [AU-X13BE, AE-X13BE]	1	AR
3-20	PGUM-A131JBEZ	Compressor sheet	1	AG
3-21	PSPF-A797JBE0	Compressor cover	1	AG
3-22	PMUF-A026JBE0	Muffler [AE-X08BE/10BE, AU-X08BE/X10BE]	1	AL
3-22	PMUF-A054JBEZ	Muffler [AE-X13BE, AU-X13BE]	1	AT
3-23	PVLVXA030JBE0	Reverse valve [AE-X08BE/X10BE]	1	BC
3-23	PVLVXA039JBE0	Reverse valve [AE-X13BE]	1	BD
3-24	LX-NZA146JBE0	Bonnet [AE-X08BE/10BE, AU-X08BE/X10BE]	1	AF
3-24	LX-NZA037JBE0	Bonnet [AE-X13BE, AU-X13BE]	1	AG

SCREWS AND NUTS

4- 1	LX-BZA091JBE0	Special screw	32	AA
4- 2	LX-BZA072JBE0	Special screw (for 2/3 way valve unit)	4	AB
4- 3	XTTSA40P14000	Tapping screw	1	AA
4- 4	LX-BZA166JBE0	Special screw	3	AB
4- 5	LX-NZA026JBE0	Special nut (for compressor)	3	AC
4- 6	LX-BZA075JBE0	Special screw	2	AA
4- 7	LX-BZA091JBE0	Special screw	7	AA
4- 8	LX-BZA075JBE0	Special screw (for Earth)	1	AA
4- 9	XBPSD40P20JS0	Machine screw (for IPM)	5	AB
4-10	LX-NZA135JBE0	Special nut (for propeller fan)	1	AC
4-11	XBPSD40P20J00	Machine screw (for DB1)	1	AA
4-12	XCTSD40P12000	Tapping screw (for Terminal board ass'y angle, for capacitor clamp)	2	AA
4-13	XTPSD30P12XS0	Tapping screw 3mm x 16mm (for PWB assembly)	2	AC
4-14	LX-BZA076JBE0	Tapping screw 3mm x 16mm (for Top cover)	8	AA
4-15	XTTSD40P16000	Tapping screw (for Heatsink)	1	AA
4-16	LX-BZA091JBE0	Special screw (for Heatsink holder)	1	AA
4-17	XCTSD40P16000	Tapping screw (for Terminal board ass'y)	1	AA

PACKING PARTS

6- 1	CPADBA031JBKZ	Bottom pad assembly	1	AS
6- 2	SPAKCA697JBEZ	Packing case [AE-X08BE]	1	AX
6- 2	SPAKCA681JBEZ	Packing case [AE-X10BE]	1	AX
6- 2	SPAKCA687JBEZ	Packing case [AE-X13BE]	1	AY
6- 2	SPAKCA700JBEZ	Packing case [AU-X08BE]	1	AX
6- 2	SPAKCA698JBEZ	Packing case [AU-X10BE]	1	AX
6- 2	SPAKCA699JBEZ	Packing case [AU-X13BE]	1	AX

HOW TO ORDER REPLACEMENT PARTS

To have your order filled promptly and correctly, please furnish the following information.

1. MODEL NUMBER
2. REF. NO.
3. PART NO.
4. DESCRIPTION

OUTDOOR UNIT FOR AE-X08BE/X10BE/X13BE AND AU-X08BE/X10BE/X13BE

