

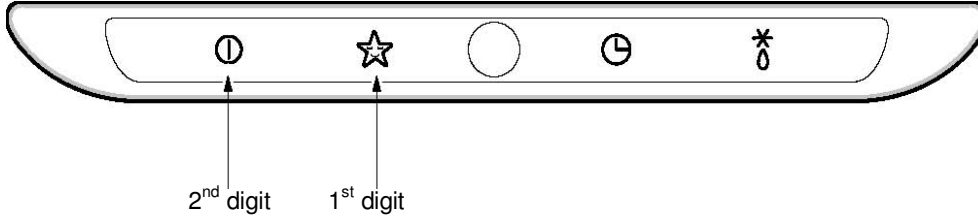

Universal and Multi Split Units

If there is a fault on any LG Universal or Multi unit, a two digit number will appear on the remote controllers led display. If the unit does not have a remote controller the fault will be displayed using the LED's on the front of the indoor unit.



The second digit of the fault code is shown by the power led which has the following symbol by it ⓘ



The first digit will be displayed by one other led.

Error Indicator:

- The function provides self-diagnosis and displays an error code if there is any trouble.
- Error codes are displayed on the Indoor unit's Wired Remote as CH**, and/or Fascia Display. In addition, the code is indicated via LED's on the outdoor unit control board.
- If more than two troubles occur simultaneously, the lower number of error code is displayed first.
- After an error occurs, if error is released, error LED is also released simultaneously.

Indoor Unit Faults:

Error code	Contents	Case of error	Indoor Status
01	Air sensor (open/short)	Open / Short circuit	Off
02	Inlet pipe sensor	Open / Short circuit	Off
03	Communication(Indoor ↔ Wired R/Control)	Communication Poorly	Off
04	Drain pump / Float switch	Float switch Open circuit (High level water alarm)	Off
05	Communication(Indoor ↔ Outdoor)	Communication Poorly	Off
06	Outlet pipe sensor	Open / Short circuit	Off
07	Different operation mode	Indoor units set in different operation modes	Off
HL	High Limit (Float Switch)	Same as code 04, Float switch Open circuit	Off
CL	Child Lock Function selected	Not an error, press Timer & Min buttons simultaneously for 3 seconds to toggle On/Off	On
Po	Jet Cool Mode selected	Not an error, press Jet Cool button to toggle On/Off	On



Outdoor Unit Faults can also be read from the outdoor unit PCB using the flashing LED's as below:

Error code	Contents	LED01G (Red)	LED02G (Green)	Case of Error	Outdoor Status
21	IPM Fault (Compressor Over current)	2 times	1 time	Compressor malfunction, IPM Fault	Off
22	CT 2 (Max. Current)	2 times	2 times	Current is 14A ↑	Off
23	DC Link Low Volt.	2 times	3 times	DC Link volt. Is 140V ↓	Off
24	Low / High Pressure	2 times	4 times	Low / High press switch OPEN	Off
25	AC Low / AC High Volts.	2 times	5 times	Abnormal AC volt. Input.	Off
26	DC Compressor Position	2 times	6 times		Off
27	PSC Fault (Reactor)	2 times	7 times		Off
28	DC Link High Volts	2 times	8 times	Off	Off
32	Discharge Pipe Temp. High (INV)	3 times	2 times	Off	Off
33	Discharge Pipe Temp. High (Cons.)	3 times	3 times	Off	Off
40	CT Circuit	4 times		CT Circuit malfunction	Off
41	D-Pipe sensor INV. (Open/Short)	4 times	1 time	Open / Short circuit.	Off
44	Air sensor (Open/Short)	4 times	4 times	Open / Short circuit	Off
45	Cond. Pipe Sensor (Open/Short)	4 times	5 times	Open / Short circuit	Off
46	Suction Pipe Sensor (Open/Short)	4 times	6 times	Open / Short circuit	Off
47	D-pipe Sensor Cons. (Open/Short)	4 times	7 times	Open / Short circuit	Off
48	D-Pipe & Air Sensor (Open)	4 times	8 times	Dual Sensor unplugged	Off
51	Over Capacity	5 times	1 times	Over Load Combination	Off
52	Communication Error (Main micom ↔ Sub micom)	5 times	2 times	Poor/Loss of Communication	Off
53	Communication Error (Indoor ↔ Outdoor)	5 times	3 times	Poor/Loss of Communication	Off
54	Outdoor 3-Phase Power Supply Reverse Phase / Missing Phase	5 times	4 times	Incorrect Wiring	Off
60	EEPROM Check Sum	6 times		Check Sum Mis-Match	Off
61	Cond. Pipe Sensor Temp. High	6 times	1 time	Cond. Temp. High	Off
62	Heat Sink Sensor Temp. High	6 times	2 times	Heat Sink Temp. High	Off
63	Cond. Pipe Sensor Temp. Low	6 times	3 times	Cond. Temp. Low	Off
65	Heat Sink Sensor (Open/Short)	6 times	5 times	Open / Short circuit	Off
67	Outdoor BLDC Fan Lock	6 times	7 times	Fan Motor/Circuit Problem	Off
105	Comms. Error (Main board ↔ Fan board)	6 times	5 times	Poor/Loss of Communication	Off

The codes are explained in detail on the following pages.



Fault code 01

Is a fault with the Indoor unit return air Thermistor

Unplug the Thermistor from the PCB and Check its resistance check against this graph:

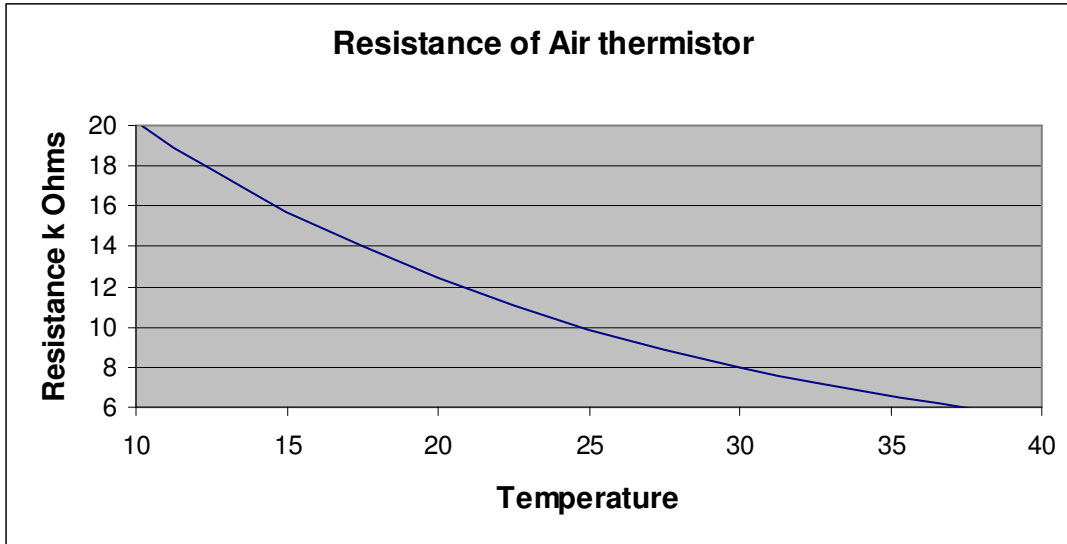

Alternatively the sensor can be tested while still connected to the PCB measure the DC voltage across the resistor and check it against the graph below.

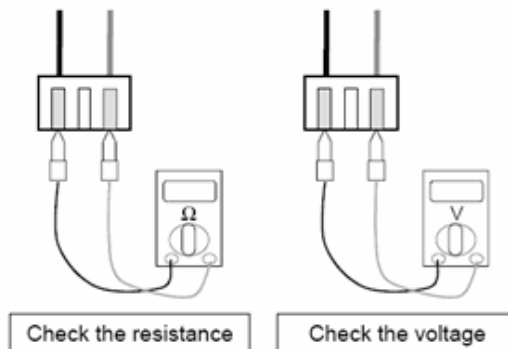
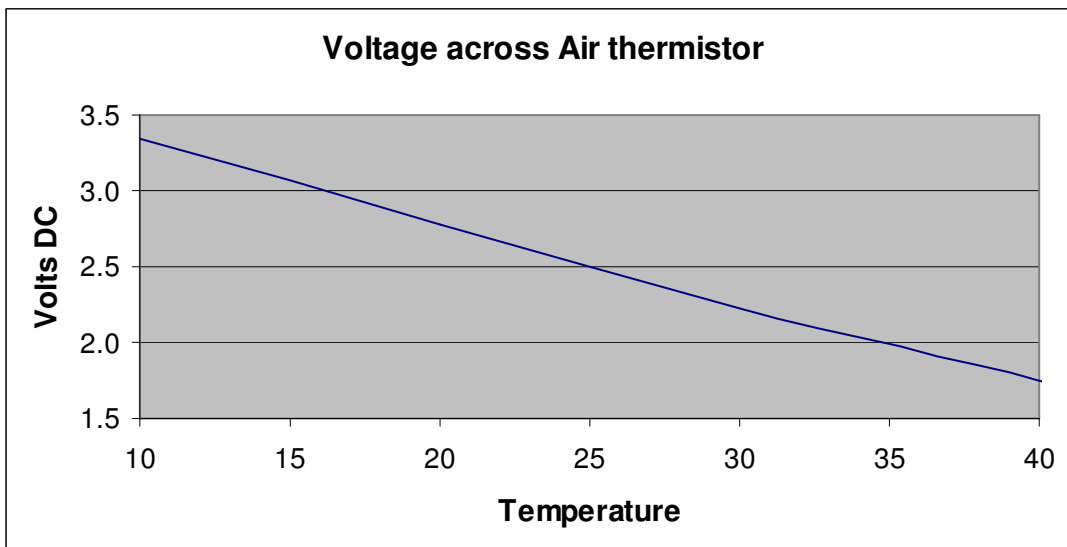



Fault code 02

Is a problem with the Indoor unit coil inlet Thermistor

Unplug the Thermistor from the indoor PCB and Check its resistance against this graph:

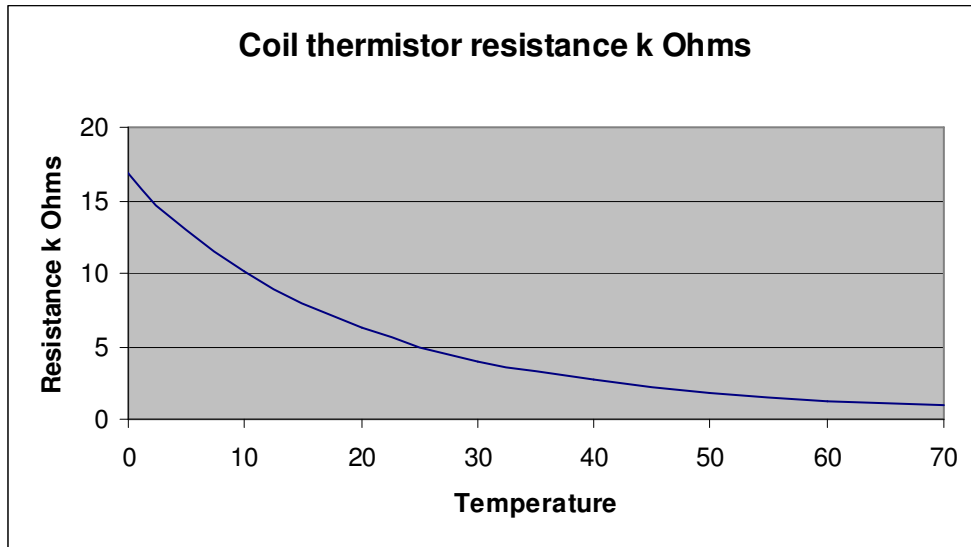

Alternatively the sensor can be tested while still connected to the PCB measure the DC voltage across the resistor and check it against the graph below.

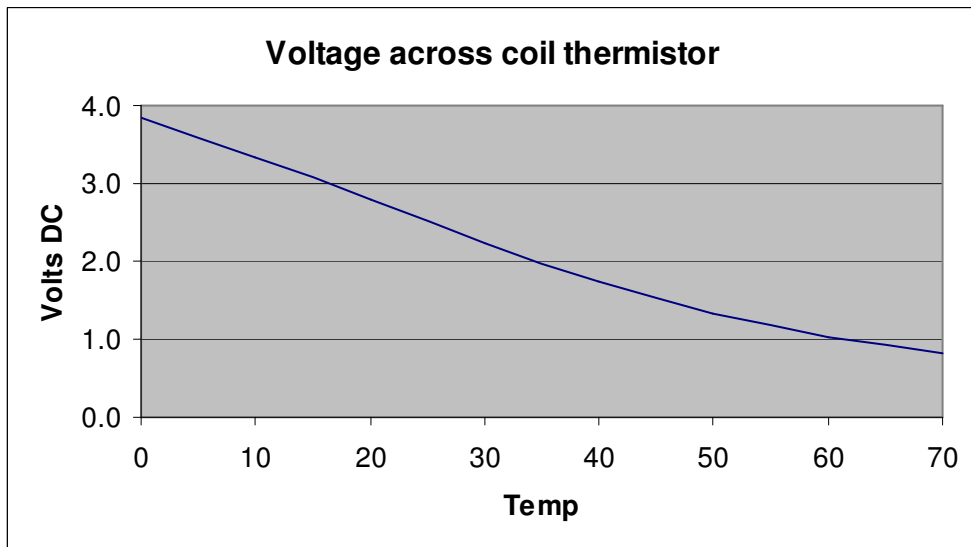



Fault Code 03

Indicates a wiring error between the remote controller and the fan coil, this is most common in **group control** applications where more than 1 fan coil is connected to a single remote controller.

Firstly check the wiring has been done correctly see below.

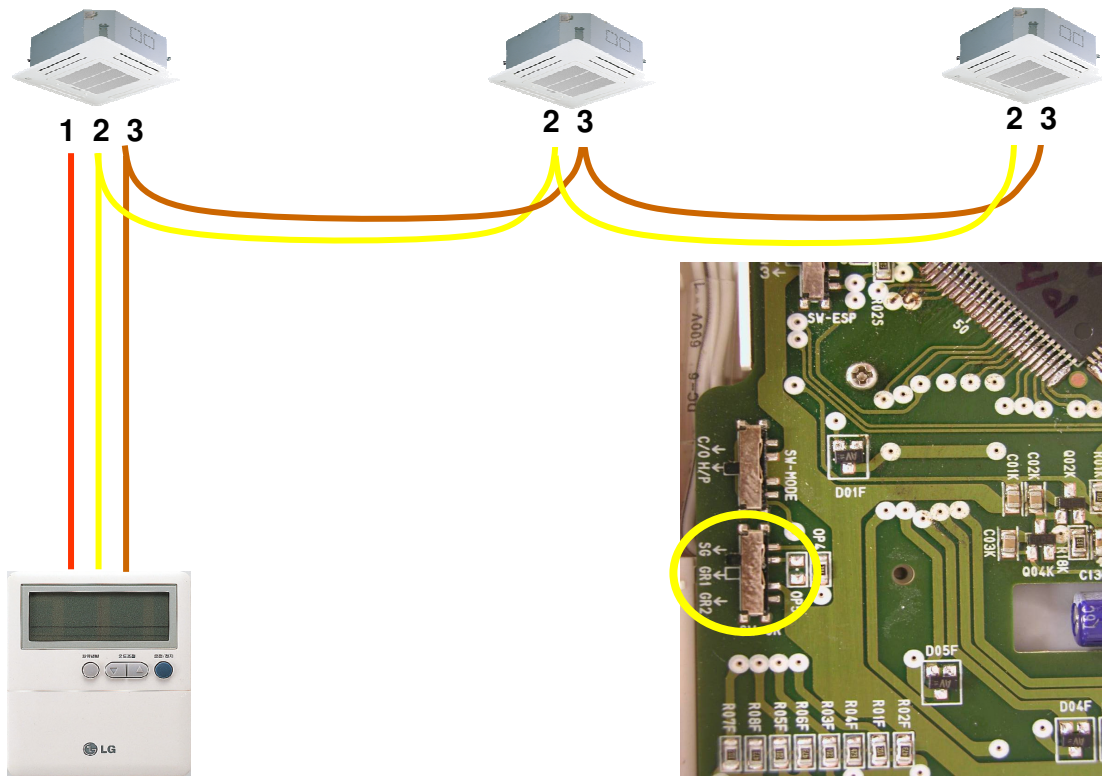

Next check the switch in the back of the remote controller, it has to be set to Group or GR1 for group control, the Factory setting is Single or SG, after setting the switch reset the power for 2 minutes. If the fault does not clear, check the Voltage of the remote controller cable.

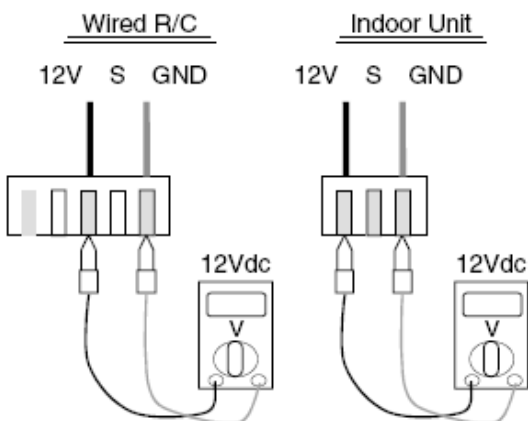

The Red cable is 12 Vdc
The Brown or Black cable is Ground or 0 Vdc
The Yellow is signal (Comms.)

Test

Voltage across the Brown/ Black cable and the Red, this should be 12 Vdc
Voltage from Yellow to Brown/Black this should be fluctuating between 8 – 12 Vdc.

**Fault Code 04**

Fault code CH04 indicates that the float switch of the fan coil has risen.

On fan coils without a drain pump it indicates that the jumper (blue plug with 30mm of blue wire) in terminal CN FLOAT is missing.

If the fan coil is running and the float rises it will take 3 ½ minutes for the fault to show on the controller, this is to give the unit time to pump excess water away. Once the float falls, (or the jumper is put back into the board) it will not be possible to clear the fault for 40 seconds. It is considered good practice to reset the power to clear this fault code.

Fault Code 05

This fault code indicates a communication error between the indoor and outdoor units; this is usually caused by wiring errors or condensate pumps connected to the inter-connecting cable.

The communication between the units is a fluctuating DC voltage commonly called a serial signal, it can be easily lost if the wiring is not done correctly. If there is a communication error fault **CH05** will appear within 5 mins of powering up the system.

Testing

Turn on the power and start the indoor unit in cooling, set the temperature to 18°C; the serial communication signal will only be present for the first 3 mins of operation.

Set your meter to DC Volts, Test between terminals 2 and 3, of the outdoor unit and wiring terminals you should see 0-65 V dc, it will be fluctuating.

If the Voltage is not present disconnect the inter unit wiring, test the Voltage on the wiring terminals again, If No Voltage is present the outdoor PCB must be faulty.

Once the signal has been detected leaving the outdoor unit check what is being received by the indoor unit, measure DC Voltage across the wiring terminal 2 and 3, it should be identical to what you saw at the outdoor unit, if not your wiring is at fault.



Fault code 06

Is a problem with the Indoor unit coil outlet Thermistor

Unplug the Thermistor from the indoor PCB and Check its resistance against this graph:

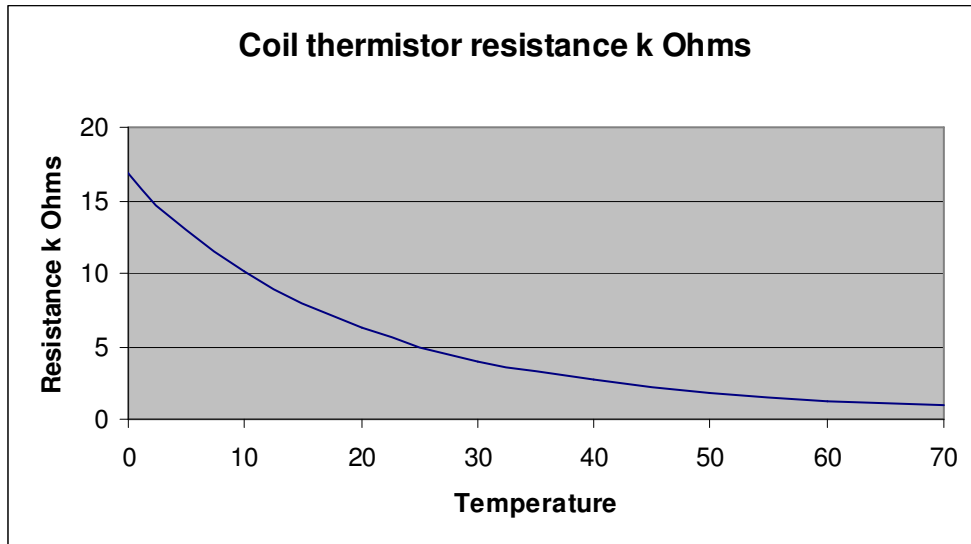

Alternatively the sensor can be tested while still connected to the PCB measure the DC voltage across the resistor and check it against the graph below.

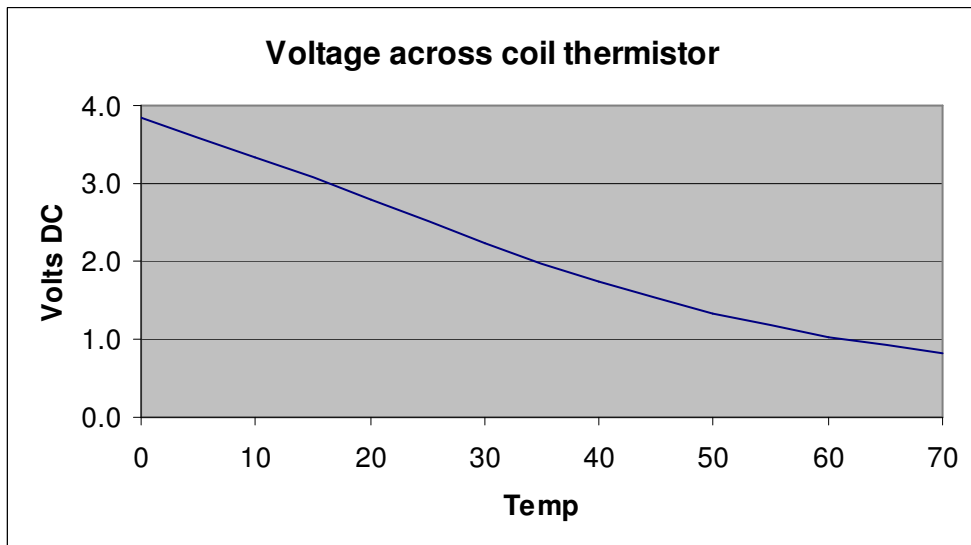



Fault Code 07

On Multi split systems, the first unit switched on is the cool heat master, the master tells the condensing unit what to do. If the condenser is in heating and any slave is set to cooling a CH07 fault code will appear. Likewise if the condenser is in cooling and any slave is set to heating a CH07 fault code will appear. If the master is switched off the next longest running unit becomes the master.

To clear the fault turn off the unit at the remote controller, turn it back on again and change the mode

Fault Code 21

This fault is caused by an over current in the inverters DC power circuit. If the DC part of the circuit exceeds 14 Amps fault code 21 will be displayed.

This is caused by either the inverter PCB being faulty or compressor being short circuit or down to earth.

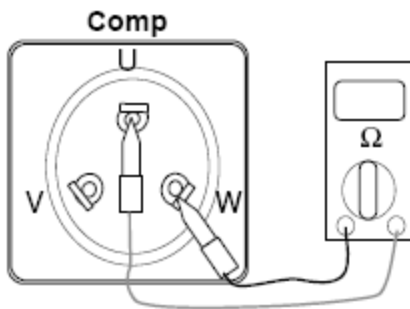

Disconnect the electrical connections to the compressor and check the resistance of the compressor windings, measure from U to V, V to W and W to U the values should be between 0.25 and 5 Ohms each.

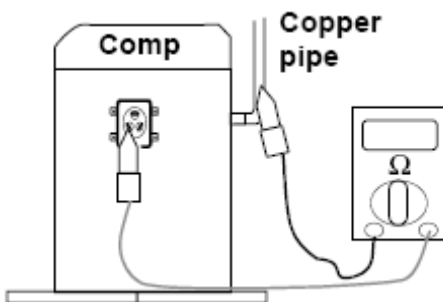

The next test is to measure the resistance of the compressor windings to earth. Using a Megger (High Voltage Meter) measure the resistance from any of the 3 compressor terminals to an Earth point (pipe work). The value should exceed 2 M Ohms.

If the compressors fail these tests it will need replacing.

If the compressor is OK you will need to check the inverter output voltages. Please see section on Inverter testing at end.

Fault Code 22

This fault is caused by a Compressor over-current see code 21

Please see section on Inverter testing at the end.

Fault Code 23

This fault indicates a fault in the DC part of the inverter circuit; it means that the Dc Voltage to the inverter is below 140 V Dc, it should be 370 V for single phase machines and 600 V dc for three phase machines. The fault is usually caused by the inverter charging resistor being faulty; this component is mounted on the outdoor unit PCB and cannot be replaced.

Start the unit running and measure the DC Voltage supply to the inverter. This is easiest to measure at the inverter capacitors; it should be 370 V for single phase machines and 600 V dc for three phase machines

See section on Inverter testing at the end.

**Fault Code 24**

If the unit has a low or high pressure fault CH24 will display.

If the LP switch goes open circuit the compressor will be stopped, on inverter units this can take up to 30 seconds. The LP Switch goes open circuit when the suction pressure falls below 0.5 bar the Hp Switch opens at 41 bar.

The fault code will only occur if the pressure switch is tripped 5 times within 1 hour, this can only be reset by switching off the power to the condensing unit for 2 minutes.

If your unit does not have any pressure switches it may still have a plug on the outdoor unit PCB labelled CN Press, it should have a link plugged in, if the link is missing it must be replaced.

Fault Code 25

This fault indicates a problem with the incoming power supply to the system.

Measure the Voltage of the incoming supply, if it is less than 140V AC or greater than 300V AC this fault will occur.

If the Power supply is correct and the fault persists replace the outdoor unit PCB.

Fault Code 26

This fault indicates a problem with the positioning system of the inverter compressor, which indicates a seized compressor.

Firstly check the compressor is correctly connected. Next reset the power supply to the system ensuring the power is left off for 5 minutes. Start the unit up, after a couple of minutes the compressor will try and start, you can hear a high pitched whine when it does. If the compressor does not start turning within a couple of seconds the whining will stop. The compressor will try to start 3 times then the fault will recur.

Fault Code 27

This fault indicates a problem with the inverter module, see section on testing inverters. Also check reactor is connected to the PCB and check its resistance it should be well under 1 Ohm.

Fault Code 28

This fault indicates a problem in the DC part of the inverter circuit; it means that the DC Voltage to the inverter is too high.

Start the unit running and measure the DC Voltage supply to the inverter. This is easiest to measure at the inverter capacitors; it should be 370 V for single phase machines and 600 V dc for three phase machines. See section on Inverter testing at end.

Fault Code 32

Indicates that the Inverter compressor discharge temperature is high (above 105°C) this usually indicates the system has either a shortage of refrigerant or a blockage in the system.

Reset the power to the unit for 2 minutes and restart it. If the compressor starts measure the compressor discharge temperature, typically it should not be more than 50°C above the ambient temperature around the condensing unit. It may take quite a long period for the compressor to overheat so don't just start the unit and run. Make sure you check the unit is operating correctly and providing adequate cooling.



Fault Code 33

Indicates that the fixed speed compressor discharge temperature is high (above 105°C) this usually indicates the system has either a shortage of refrigerant or a blockage in the system.

Reset the power to the unit for 2 minutes and restart it, If the compressor starts measure the compressor discharge temperature, typically it should not be than 50°C above the ambient temperature around the condensing unit. It may take quite a long period for the compressor to overheat so don't just start the unit and run. Make sure you check the unit is operating correctly and providing adequate cooling.

Fault Code 40

This fault indicates a problem with the current drawn by the AC part of the inverter circuit.

Refer to the inverter testing procedure at the end.



Fault Code 41

This fault indicates an Inverter Compressor discharge Thermistor fault
Unplug the Thermistor and Check its resistance check against this graph:

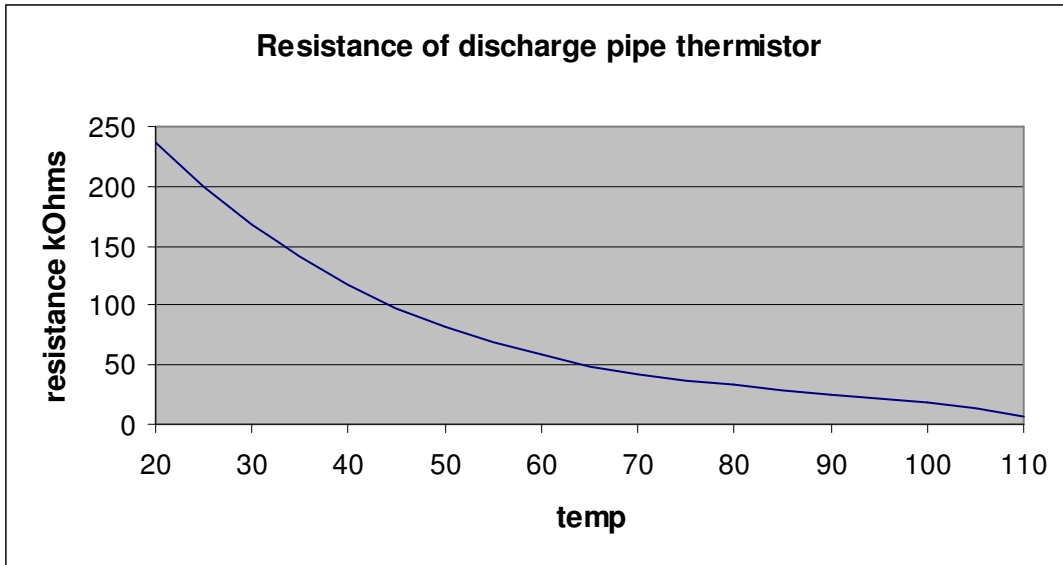

Alternatively the sensor can be tested while still connected to the PCB measure the DC voltage across the resistor and check it against the graph below.

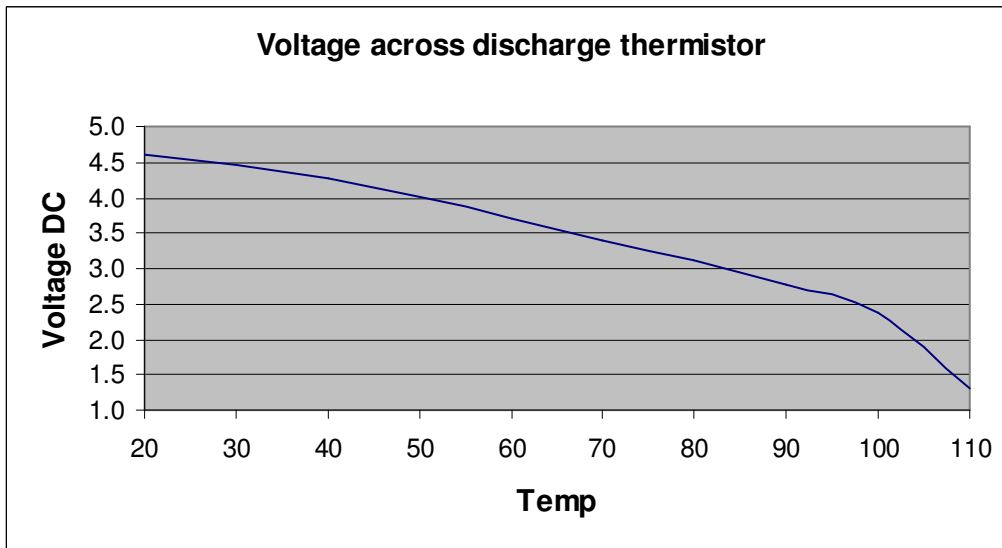



Fault Code 44

Indicates a fault with the Outdoor unit air Thermistor

Unplug the Thermistor from the PCB and Check its resistance check against this graph:

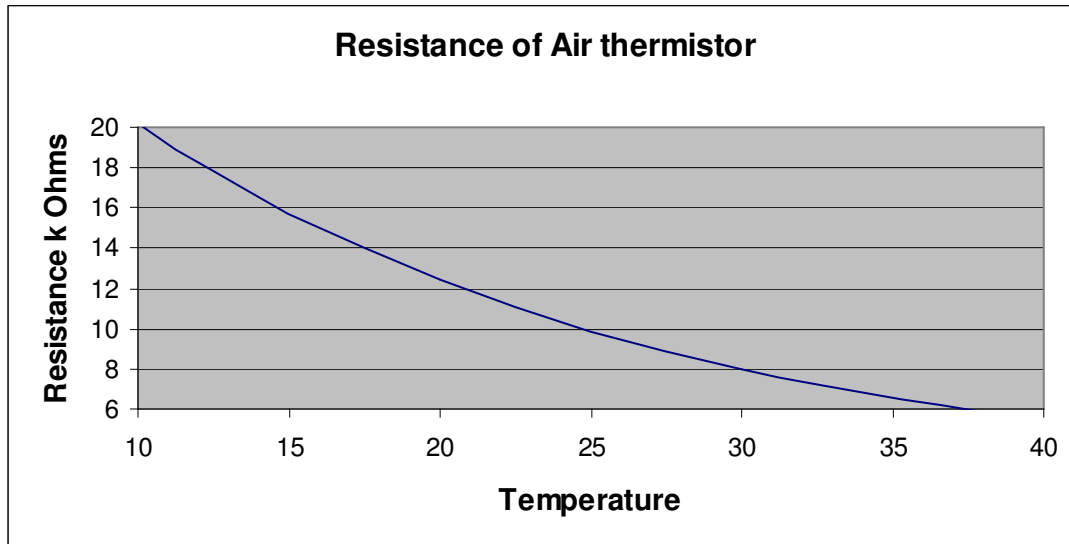

Alternatively the sensor can be tested while still connected to the PCB measure the DC voltage across the resistor and check it against the graph below.

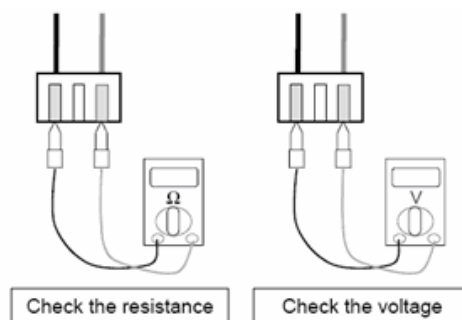
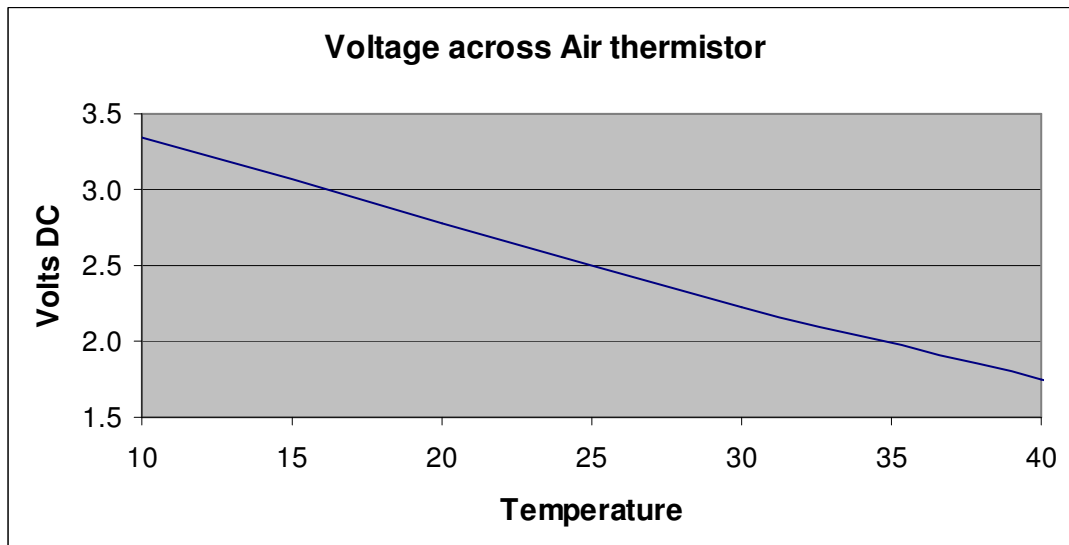



Fault Code 45

Indicates a problem with the condenser coil outlet Thermistor

Unplug the Thermistor from the indoor PCB and Check its resistance against this graph:

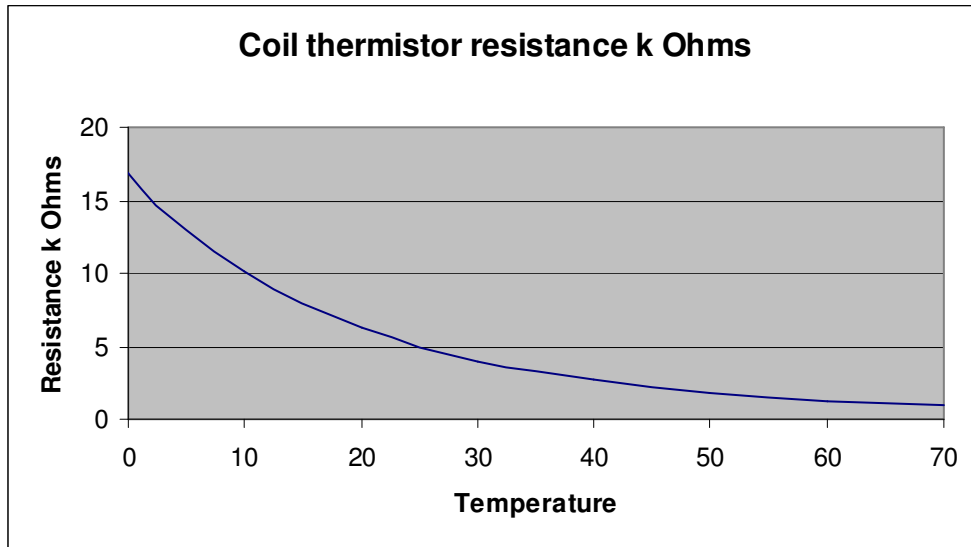

Alternatively the sensor can be tested while still connected to the PCB measure the DC voltage across the resistor and check it against the graph below.

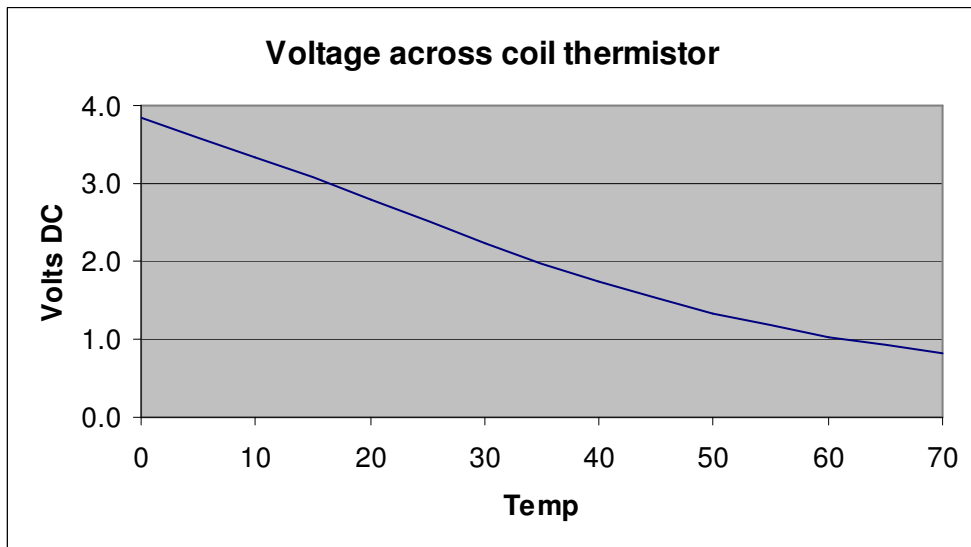



Fault Code 46

Indicates a problem with the compressor suction Thermistor

Unplug the Thermistor from the indoor PCB and Check its resistance against this graph:

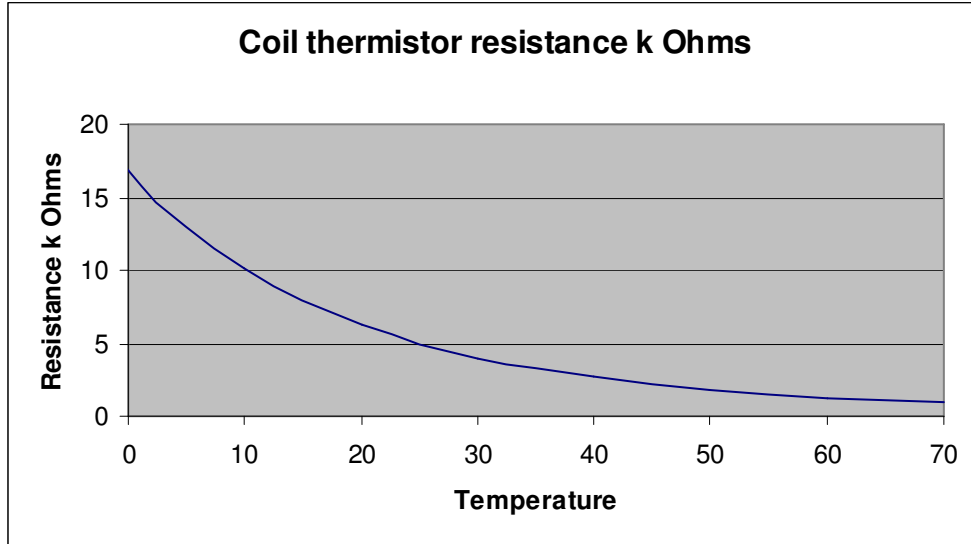

Alternatively the sensor can be tested while still connected to the PCB measure the DC voltage across the resistor and check it against the graph below.

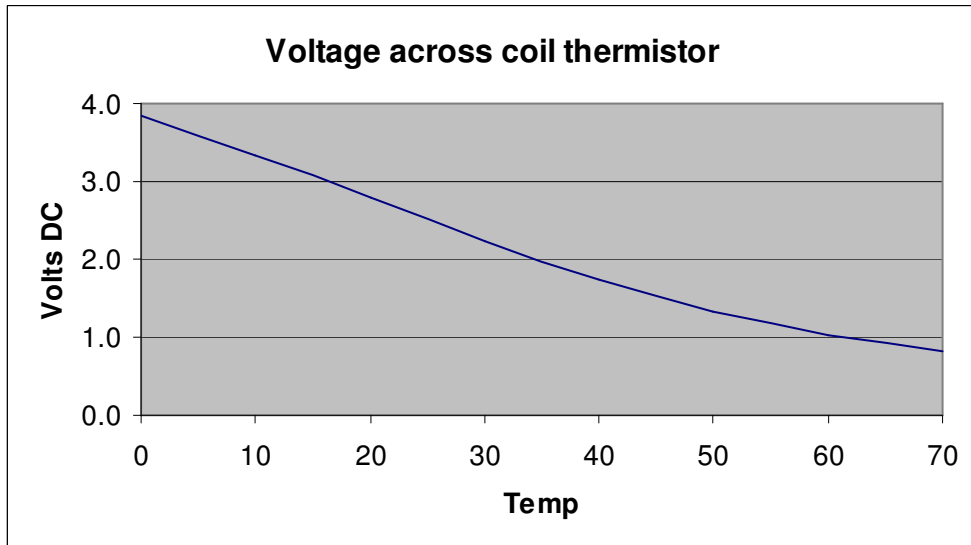



Fault Code 47

Indicates an Inverter Compressor discharge Thermistor fault
Unplug the Thermistor from the PCB and Check its resistance check against this graph:

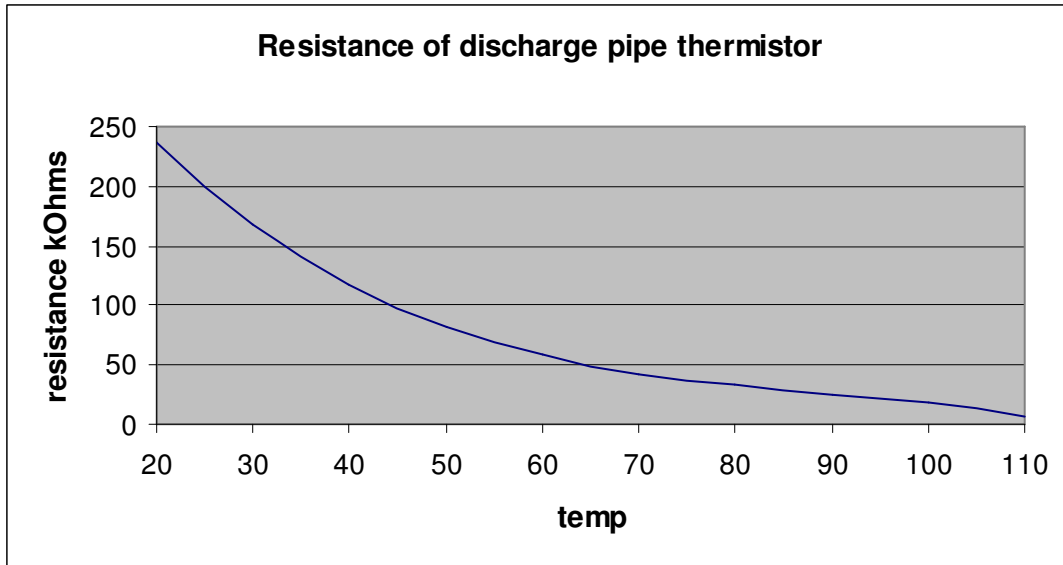

Alternatively the sensor can be tested while still connected to the PCB measure the DC voltage across the resistor and check it against the graph below.

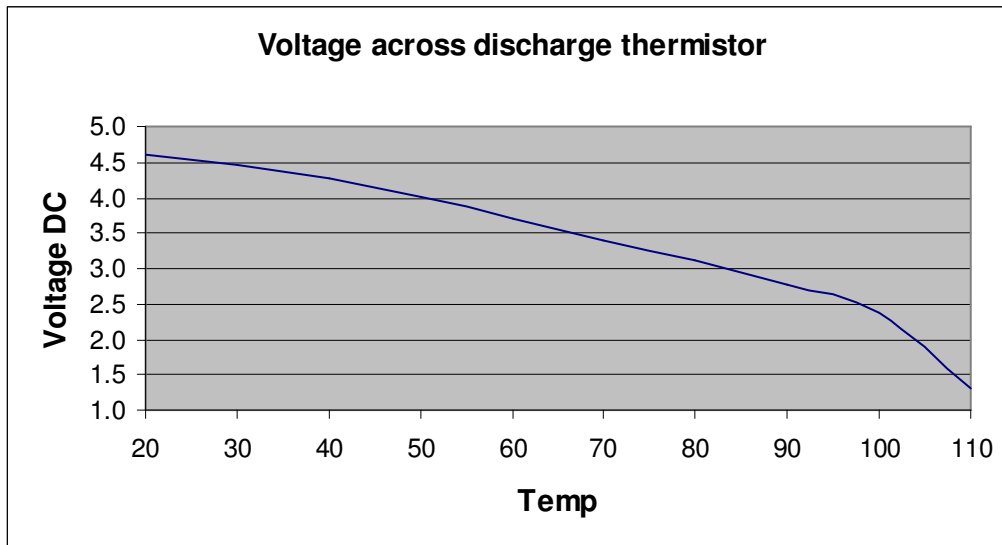

**Fault Code 48**

This fault indicates that the compressor discharge sensor and the condenser air temperature sensors are both unplugged. Both these sensors are connected to a single connector on the outdoor unit PCB, plug it in and the fault will go away.

Fault Code 51

This indicates that the capacity of the indoor unit / units is too great for the condensing unit. Make a note of the model number of the fan coil/coils and the condensing unit and check with the equipment supplier that the units you have installed can be connected together.

Fault Code 52

This fault code indicates a communication error between the Main and Sub micom (CPU's) on the outdoor unit main PCB. Check for evidence of damage, if none found reset power, if fault reappears replace pcb.

Fault Code 53. (see fault code 05)**Fault Code 54**

This fault normally indicates a lost phase or the phases are reversed on the power supply to 3 phase units.

Check all 3 phases are available at the power terminals to the unit. You should have 415v AC across red to blue, blue to yellow and red to yellow,

If this is all ok turn off the power and swap the red and yellow cores of the power supply cable over, reset the power and the unit will operate.

Fault Code 60

Check the correct PCB assembly has been installed, check for dry joints, replace outdoor unit PCB if nothing is found.

Fault Code 61

Indicates the outdoor unit condenser coil temperature is high above 65°C, this will usually be experienced in cooling mode and will indicate insufficient air being drawn over the coil.

Check there are no blockages to the coil (carrier bags dirt etc); check the air flow is not short circuiting from the front to the back of the unit and check for Nitrogen in the system.

Fault Code 62

Indicates the outdoor unit Inverter heat-sink thermistor has detected that the heat sink is overheating 85°C. This is usually caused by debris blocking the heat-sink fins or an error with the thermistor, see code 65.



Fault Code 65

Is a problem with the Inverter PCB heat sink thermistor for the heat sink on the outdoor unit PCB, unplug the Thermistor from the PCB and Check its resistance against this graph:

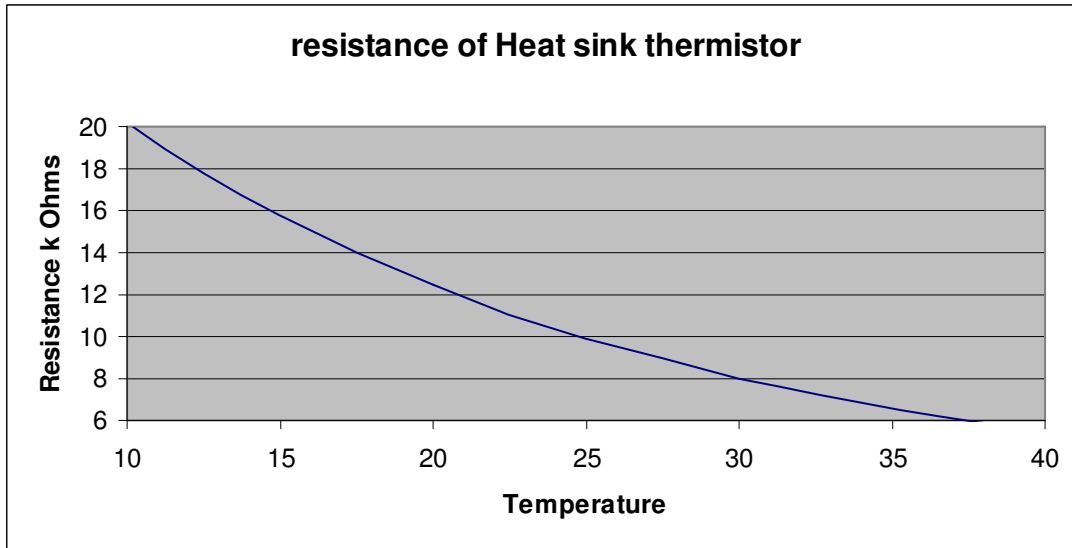

Alternatively the sensor can be tested while still connected to the PCB measure the DC voltage across the resistor and check it against the graph below.

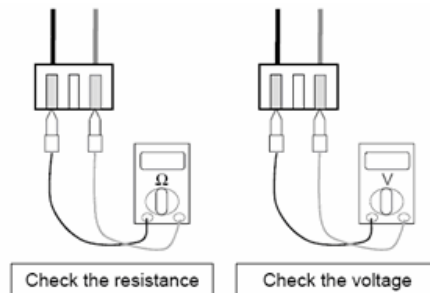
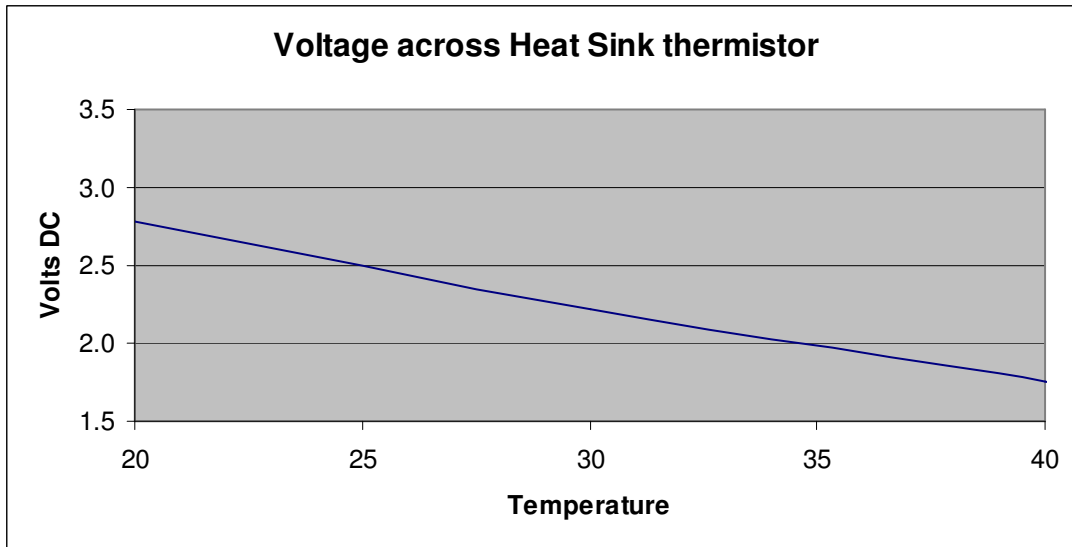

**Fault Code 67**

This is a problem with the Outdoor Fan Motor, where rotation is not detected, and could be result of either Mechanical or Electrical failure.

- Check that motor is free to rotate and not seized.
- Check the motor is electrically sound, windings not Open or Short circuit.
- Check power output from PCB to fan motor.
- Check rotation feedback circuit.

More modern units use **inverter fan motors**, which are powered by a DC Voltage. In reality these fan motors are AC fan motors with a small inverter-type circuit build inside. This inverter circuit is integrated with the fan motor and impossible to replace, you have to replace the entire fan motor.

Similar to inverter-controlled compressors, the speed of these fan motors can be changed to whatever is needed (within certain limits). In practice the change in fan speed is not 'continuous' but certain fixed speeds have been programmed inside the AC unit.

This type of fan control can be recognized by the 5 wires coming from the fan on a connector with 7 possible connections

These fan motors have 5 connections, power supply is 360VDC, and the speed is determined by a voltage ranging from 0 (0 rpm) to 5VDC (max speed) and a power supply for the internal electronics of 15VDC.

These motors are easy to identify from a wiring diagram, they always show them not connected to anything as the electronics are too difficult to draw on the diagram.

Detail of Hall Sensors

A Hall effect sensor works like a magnetic reed switch, one end is wired to a 15 Vdc supply and the other is the feed back to the PCB. As a magnet mounted on the rotor of the motor passes the hall sensor the reed switch closes momentarily and allows the DC signal to flow through it back to the PCB. The hall sensors have a resistance so the voltage fed back to the PCB will only be approximately 12V DC.

The pcb will know what speed the fan motor should be turning as it is also controlling the output of the inverter, if there is a discrepancy between the inverter output RPM and the feedback from the hall sensors a fault will occur. Usually the fan will rev very fast for a few seconds then stop this indicates hall sensor problems.

Replace either Motor or Fan PCB as necessary.

Fault Code 105

This is due to a Communication error between the Main outdoor PCB and Fan PCB.

- Check for Open/Short of communication line between the Main and Fan PCB's.
- Check communication cable plug connections.
- Is the communication LED on?



Testing Inverters

It is best to test inverters with no compressors connected especially if you expect the compressor is at fault. But if you remove the wires from the compressor and try to run the systems a fault will be displayed. The fault is caused by the inverter PCB being able to detect whether a compressor is connected or not. Most modern inverters are able to detect whether the compressor has been disconnected in only a few seconds making testing very difficult.

Testing can be done in two ways:

Firstly the hard way.....

You will need a digital multi meter with a min max function,

Turn off the power

Disconnect the compressor either from the PCB or at the compressor terminals.

Connect your meter to two of the phases (Red to blue) set your meter to record max and min voltage

Power up and Start the unit

Let the inverter start and watch the Voltage rise

Record the maximum Voltage

The inverter will stop after a few seconds and the voltage will fall to 0

Swap the leads to measure the next two phases (Red to Yellow).

Measure as before

Repeat for the last two phases Blue to Yellow.

The readings of maximum voltage should be the same for all 3 measurements if not the inverter is faulty, the PCB will need replacing.

If the readings are equal the Inverter is healthy and the compressor will need replacing.

And the easy way:

You will need an LG Inverter tester,

Turn off the power

Disconnect the compressor lead from the compressor terminals.

Connect your inverter tester to all 3 leads (polarity is not important)

Power up and Start the unit

Let the inverter start and watch the led's

All 6 must light up and should be of equal brightness

The inverter will stop after a few seconds and the led's will go out

If you miss the led's (they will only light for a couple of seconds) the unit will try to start again 3 times with a 3 minute delay between each test

If all 6 led's DON'T light up the inverter is faulty, the PCB will need replacing.

If the led's all light up the Inverter is healthy and the compressor will need replacing.