

SHARP SERVICE MANUAL

S8235AYXP13CE

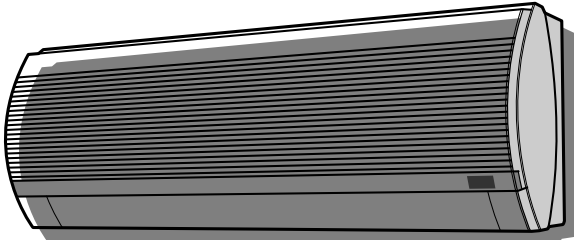

SPLIT TYPE ROOM AIR CONDITIONERS

INDOOR UNIT

AY-XP08CE

AY-XP10CE

AY-XP13CE

OUTDOOR UNIT

AE-X08BE-C

AE-X10BE-C

AE-X13BE

MODELS



In the interests of user-safety (Required by safety regulations in some countries) the set should be restored to its original condition and only parts identical to those specified should be used.

TABLE OF CONTENTS

	Page
SPECIFICATIONS	2
EXTERNAL DIMENSIONS	3
WIRING DIAGRAMS	5
ELECTRICAL PARTS	9
BLOCK DIAGRAM	10
MICROCOMPUTER CONTROL SYSTEM	12
FUNCTIONS	17
FUNCTION AND OPERATION OF PROTECTIVE PROCEDURES	27
BREAKDOWN DIAGNOSIS PROCEDURE	29
REFRIGERATION CYCLE	32
PERFORMANCE CURVES	33
DISASSEMBLING PROCEDURE	34
OPTION	41
REPLACEMENT PARTS LIST	43

SPECIFICATIONS

ITEMS	MODEL	INDOOR UNIT	OUTDOOR UNIT	INDOOR UNIT	OUTDOOR UNIT	INDOOR UNIT	OUTDOOR UNIT
		AY-XP08CE	AE-X08BE-C	AY-XP10CE	AE-X10BE-C	AY-XP13CE	AE-X13BE
Cooling capacity(Min. ~ Max.)	kW	2.2(0.9 – 2.7)		2.8(0.9 – 3.3)		3.6(0.9 – 4.2)	
Heating capacity(Min. ~ Max.)	kW	3.2(0.9 – 3.6)		3.7(0.9 – 5.0)		4.8(1.0 – 6.2)	
Moisture removal(at cooling)	Liters/h	0.7		0.8		1.3	

Electrical data

Phase			Single					
Rated frequency		Hz	50					
Rated voltage		V	220 - 240					
Rated current ★	Cool	A	3.4 – 3.1		4.3 – 4.0		5.5 – 5.1	
	Heat	A	4.2 – 3.9		4.8 – 4.4		6.8 – 6.2	
Rated input ★	Cool	W	730		930		1200	
	Heat	W	910		1050		1480	
Power factor ★	Cool	%	98 – 98		98 – 97		99 – 98	
	Heat	%	98 – 97		99 – 99		99 – 99	
Compressor	Type		Hermetically sealed rotary type					
	Model		44A072QV2JD		HV187X1-S12F3		HV237A1-S15DK	
	Oil charge		280cc (SUNISO 4GST)		370cc (SUNISO 4GSD)		455cc (SUNISO 4GSD)	
Refrigerant system	Evaporator		Louver Fin and Grooved tube type					
	Condenser		Corrugate Fin and Grooved tube type					
	Control		Capillary tube					
	Refrigerant volume		760g		850g		880g	
De-Ice system		Micro computer controled reversed systems						
Noise level (at cooling)	High	dB(A)	33	43	36	43	38	48
	Med.	dB(A)	29	–	32	–	33	–
	Low	dB(A)	27	–	27	–	29	–

Fan system

Drive			Direct drive					
Air flow quantity (at cooling)	High	m ³ /min.	7.5	28	9.8	27.7	9.4	30
	Med.	m ³ /min.	6.5	–	8.0	–	8.0	–
	Low	m ³ /min.	5.1	–	6.0	–	6.5	–
Fan			Cross flow fan	Propeller fan	Cross flow fan	Propeller fan	Cross flow fan	Propeller fan

Connections

Refrigerant coupling		Flare type					
Refrigerant tube size Gas, Liquid		3/8", 1/4"				1/2", 1/4"	
Drain piping mm		O.D ø 18					

Others

Safety device			Compressor: Thermal protector					
			Fan motors: Thermal fuse					
			Fuse, Micro computer control					
Air filters			Polypropylene net (Washable)					
Net dimensions	Width	mm	815	780	815	780	815	780
	Height	mm	278	540	278	540	278	540
	Depth	mm	198	269	198	269	198	269
Net weight		kg	9	36	10	36	10	39

Note: The condition of star " ★ " marked item are 'ISO5151' : 1994(E), condition T1.

EXTERNAL DIMENSIONS

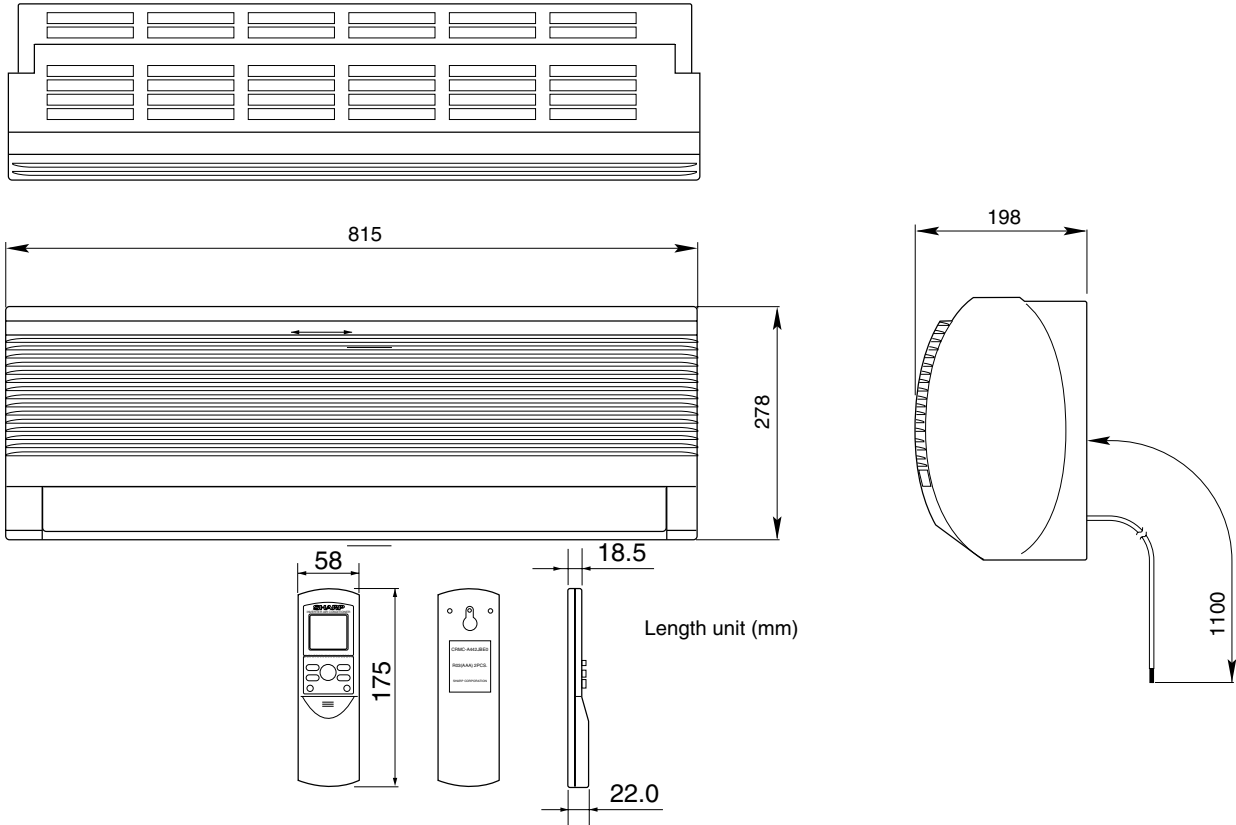

Figure E-1. INDOOR UNIT

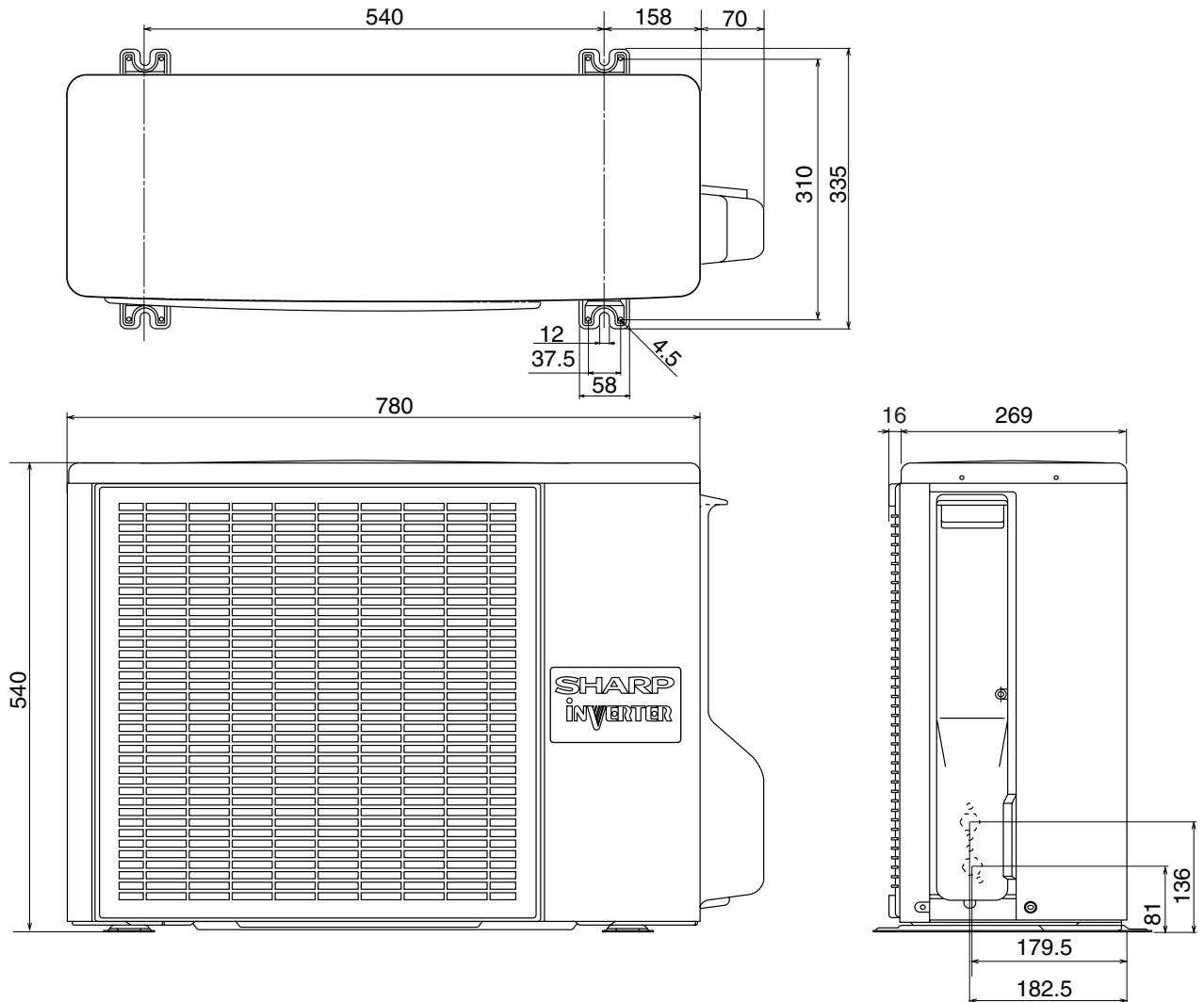

Figure E-2. OUTDOOR UNIT

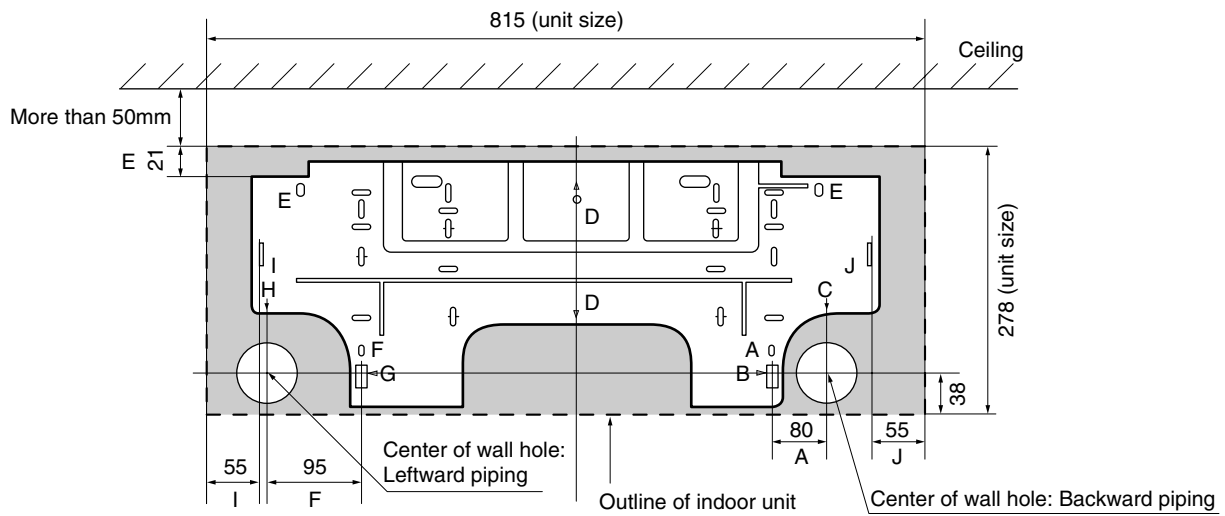

Figure E-3. INSTALLATION DIMENSIONS

WIRING DIAGRAMS

LED INDICATION FOR SELF-DIAGNOSIS

Temperature Indicator Blinking No.	Abnormal contents
1	Short circuit of the outdoor thermistor
2	Overheat of the compressor
3	Abnormal AC current
4	Compressor lock
5	Open circuit of the outdoor thermistor
6	Power module (IPM) abnormality
7	AC overcurrent
14	Abnormal power factor module (AFM)
17	Open circuit of serial signal line
18	Short circuit of serial signal line
19	Abnormal fan motor of indoor unit

<Indication of the abnormal condition>
 LED indicator will blink, if the set
 is in abnormal condition.

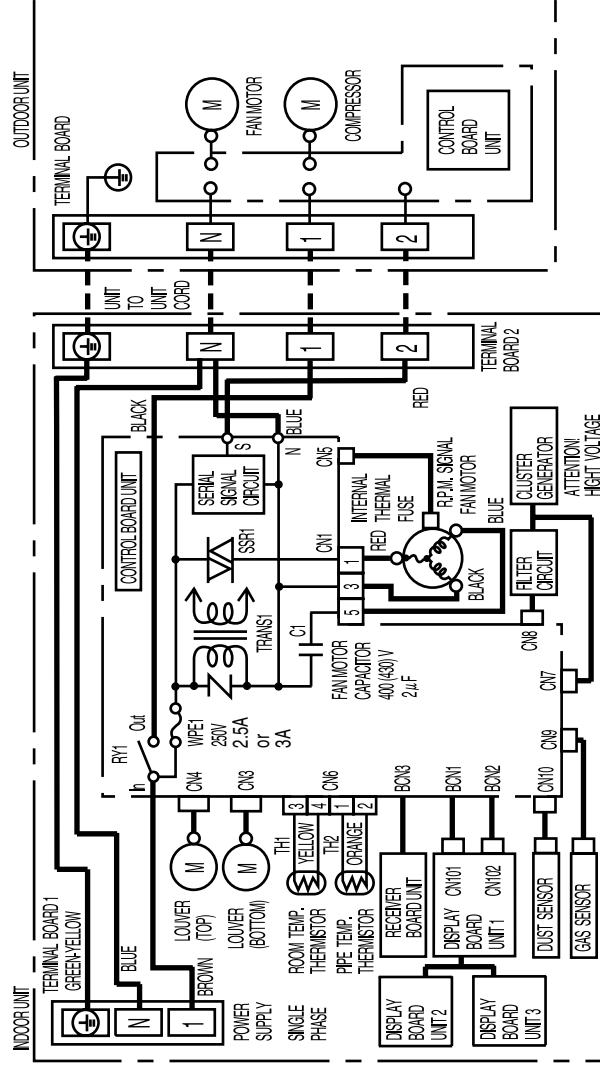
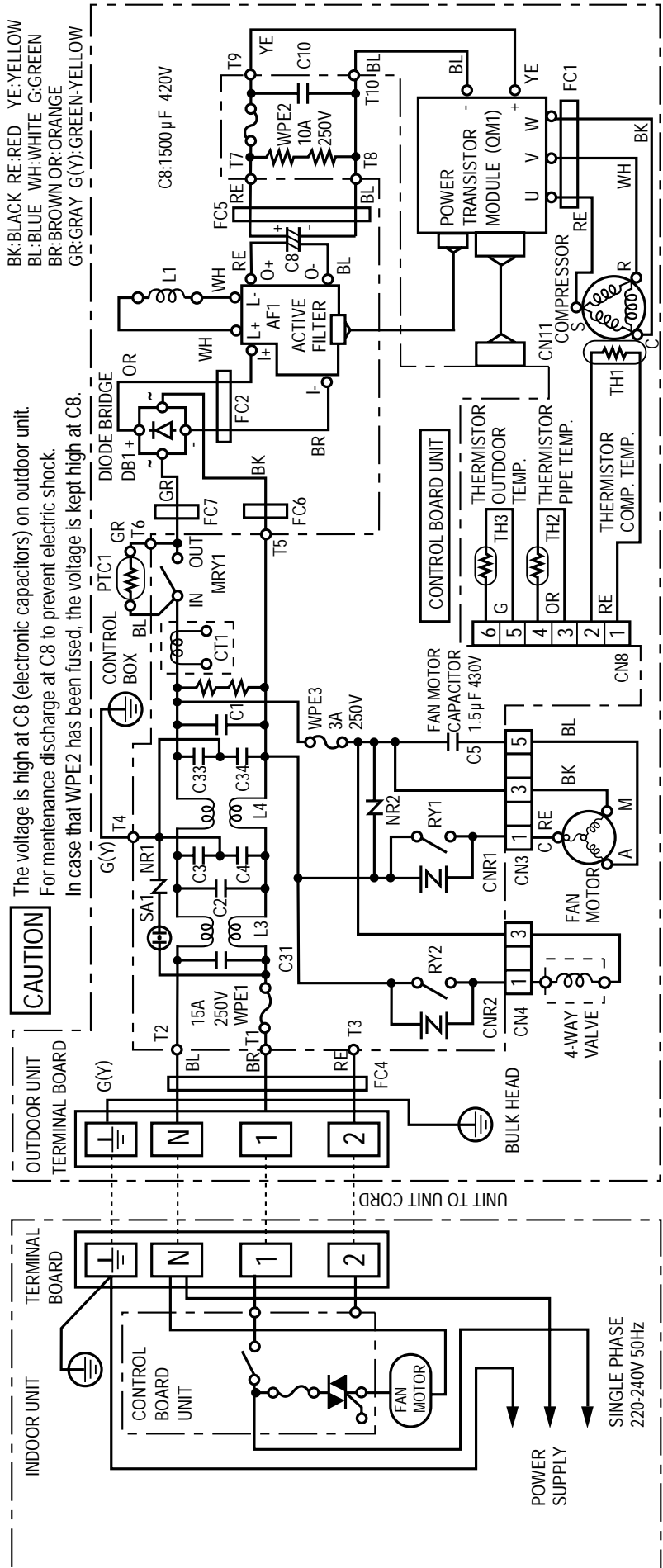

Figure W-1. Wiring Diagram for AY-XP08CE/XP10CE/XP13CE



BK:BLACK RE:RED YE:YELLOW
 BL:BLUE WH:WHITE G:GREEN
 BR:BROWN OR:ORANGE
 GR:GRAY G(Y):GREEN-YELLOW

CAUTION

The voltage is high at C8 (electronic capacitors) on outdoor unit.
 For maintenance discharge at C8 to prevent electric shock.
 In case that WPE2 has been fused, the voltage is kept high at C8.

LED INDICATION OF SELF-DIAGNOSIS

ON OUTDOOR UNIT

LED BLINKING
LED turns on
Slow flashing (1 time for 2 seconds)
Quick flashing (3 times for 2 seconds)

Example: NO.2 Compressor lock

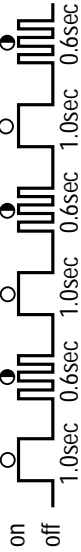

LED INDICATION PATTERN

NO.	LED indication pattern	Multifunction part or abnormal condition
1	○ ●	Normal
2	○ ○ ●	Abnormal signal line
3	○ ○ ● ○	Compressor lock
4	○ ○ ● ○ ○	Overheat of the compressor
	○ ○ ● ○ ○ ○	Power module (CM1) abnormality

LED INDICATION PATTERN

NO.	LED indication pattern	Multifunction part or abnormal condition
5	○ ○ ○ ○ ○	Short circuit of the thermistor
6	○ ○ ○ ○ ○ ○	Open circuit of the thermistor
7	○ ○ ○ ○ ○ ○ ○	AC abnormal current
8	○ ○ ○ ○ ○ ○ ○ ○	AC overcurrent
9	○ ○ ○ ○ ○ ○ ○ ○ ○	Power factor module error

NO.3 Overheat of the compressor



Figure W-2. Wiring Diagram for AE-X08BE-C

WIRING DIAGRAM

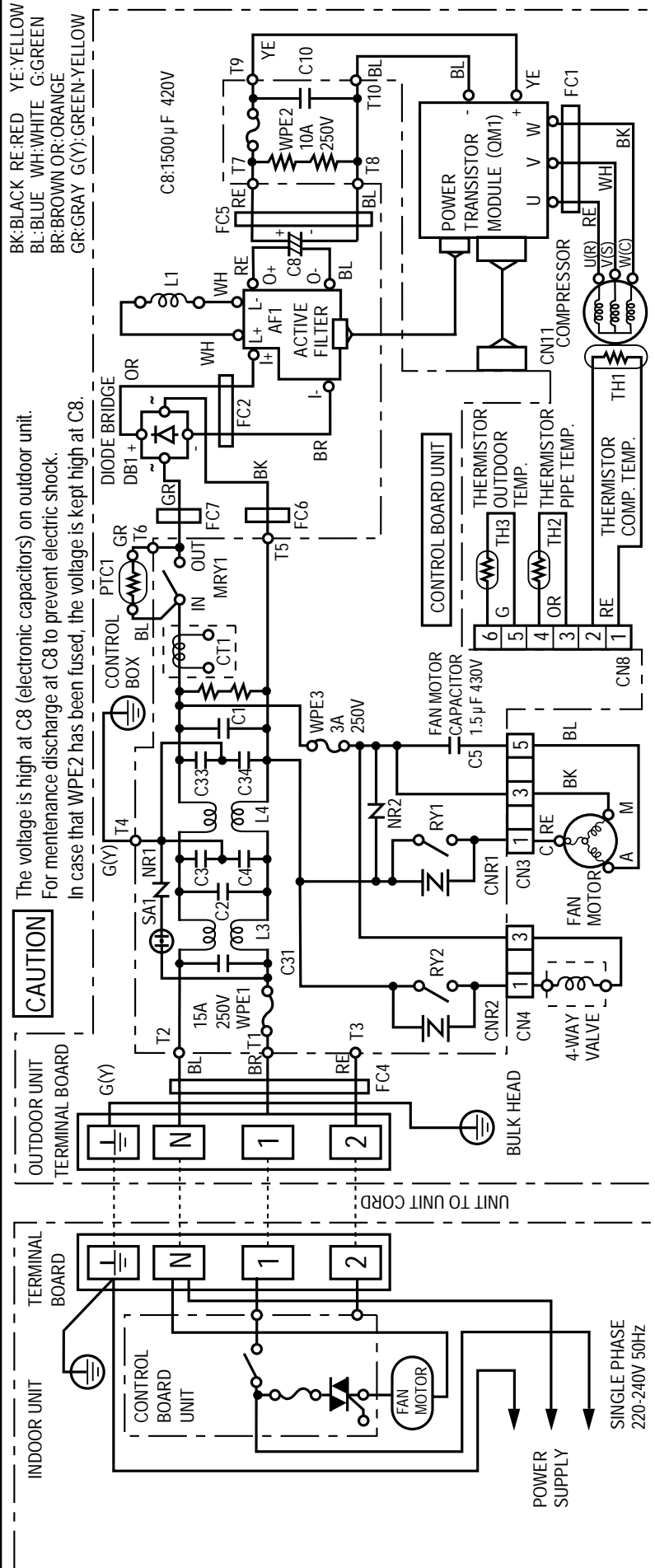

LED INDICATION OF SELF-DIAGNOSIS

ON OUTDOOR UNIT

LED BLINKING
LED turns on
Slow flashing (1 time for 2 seconds)
Quick flashing (3 times for 2 seconds)

Example: NO.2 Compressor lock

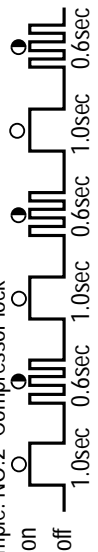

NO.	LED indication pattern	Multifunction part or abnormal condition
1	○	Normal
2	●	Abnormal signal line
3	○●	Compressor lock
4	○●●	Overheat of the compressor

NO.3 Overheat of the compressor



NO.	LED indication pattern	Multifunction part or abnormal condition
5	○●●●●	Short circuit of the thermistor
6	○●●●●●	Open circuit of the thermistor
7	○●●●●●●	AC abnormal current
8	○●●●●●●●	AC overcurrent
9	○●●●●●●●●●	Power factor module error

Figure W-3. Wiring Diagram for AE-X10BE-C

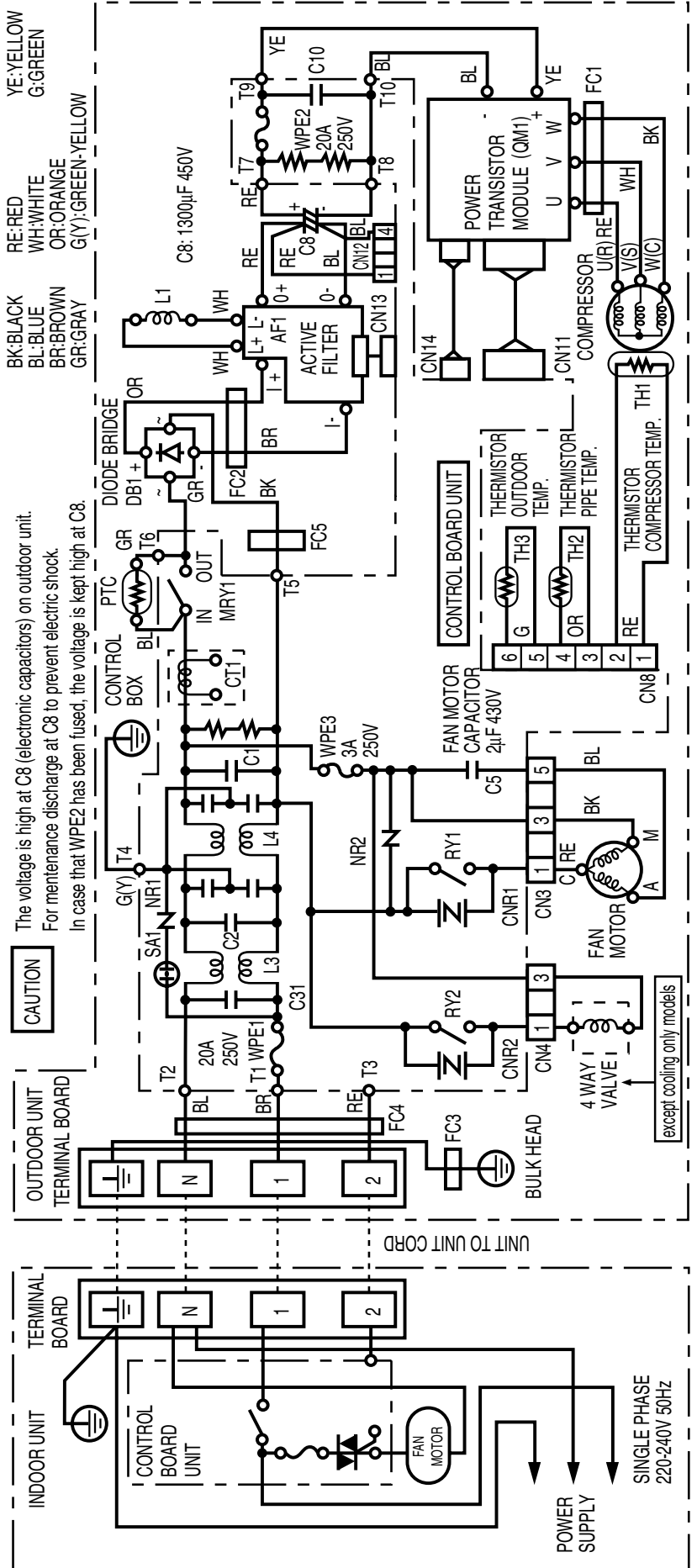

CAUTION
 The voltage is high at C8 (electronic capacitors) on outdoor unit.
 For maintenance discharge at C8 to prevent electric shock.
 In case that WPE2 has been fused, the voltage is kept high at C8.

LED INDICATION OF SELF-DIAGNOSIS ON OUTDOOR UNIT		LED INDICATION PATTERN		MULTIFUNCTION PART OR ABNORMAL CONDITION	
	LED BLINKING	NO.	LED indication pattern	Multifunction part or abnormal condition	
●	LED turns on	5	○●●●●●	Short circuit of the thermistor	
○	Slow flashing (1 time for 2 seconds)	6	○●●●●○	Open circuit of the thermistor	
●	Quick flashing (3 times for 2 seconds)	7	○●●●●●●	AC abnormal current	
		8	○●●●●●●●	AC overcurrent	
		9	○●●●●●●●●●	Power factor module error	

LED INDICATION PATTERN		MULTIFUNCTION PART OR ABNORMAL CONDITION	
○	Normal	NO.3	Overheat of the compressor
●	Abnormal signal line		
○●	Compressor lock		
○●●	Overheat of the compressor		
○●●●	QM1 (IPM) Abnormality		

ON	OFF	Example: NO.2 Compressor lock
1.0sec	0.6sec	1.0sec 0.6sec 1.0sec 0.6sec
1.0sec	0.6sec	1.0sec 0.6sec 1.0sec 0.6sec
1.0sec	0.6sec	1.0sec 0.6sec 1.0sec 0.6sec

Figure W-4. Wiring Diagram for AE-X13BE

ELECTRICAL PARTS

For Model AY-XP08CE/XP10CE/XP13CE

DESCRIPTION	MODEL	REMARKS	SITE
Indoor fan motor	ML-A915	220 - 240V, 50Hz	AY
Indoor fan motor capacitor	–	430V, 2 μ F	AY
Transformer	–	Primary; AC 220 - 240V, 50Hz Secondary; AC19V, 50Hz	AY
WPE1	–	QFS-GA040JBZZ (250V, 3A)	AY

For Model AE-X08BE-C

Compressor	44A072QV2JD	3-PHASE Induction motor	AE
Outdoor fan motor	ML-A902	220 - 240V, 50Hz 220V, 60Hz	AE
Outdoor fan motor capacitor	–	430V, 1.5 μ F	AE
WPE1	–	QFS-GA033JBZZ(15A, 250V)	AE
WPE2	–	QFS-GA015JBE0(10A, 250V)	AE
WPE3	–	QFS-GA040JBZZ(3A, 250V)	AE

For Model AE-X10BE-C

Compressor	HV187X1-S12F3	3-PHASE Induction motor	AE
Outdoor fan motor	ML-A902	220 - 240V, 50Hz 220V, 60Hz	AE
Outdoor fan motor capacitor	–	430V, 1.5 μ F	AE
WPE1	–	QFS-GA033JBZZ(15A, 250V)	AE
WPE2	–	QFS-GA015JBE0(10A, 250V)	AE
WPE3	–	QFS-GA040JBZZ(3A, 250V)	AE

For Model AE-X13BE

Compressor	HV237A1-S15DK	3-PHASE Induction motor	AE
Outdoor fan motor	ML-A903	220 - 240V, 50Hz 220V, 60Hz	AE
Outdoor fan motor capacitor	–	430V, 2.0 μ F	AE
WPE1	–	QFS-GA014JBE0(20A, 250V)	AE
WPE2	–	QFS-GA019JBE0(20A, 250V)	AE
WPE3	–	QFS-GA040JBZZ(3A, 250V)	AE

BLOCK DIAGRAMS

INDOOR UNIT

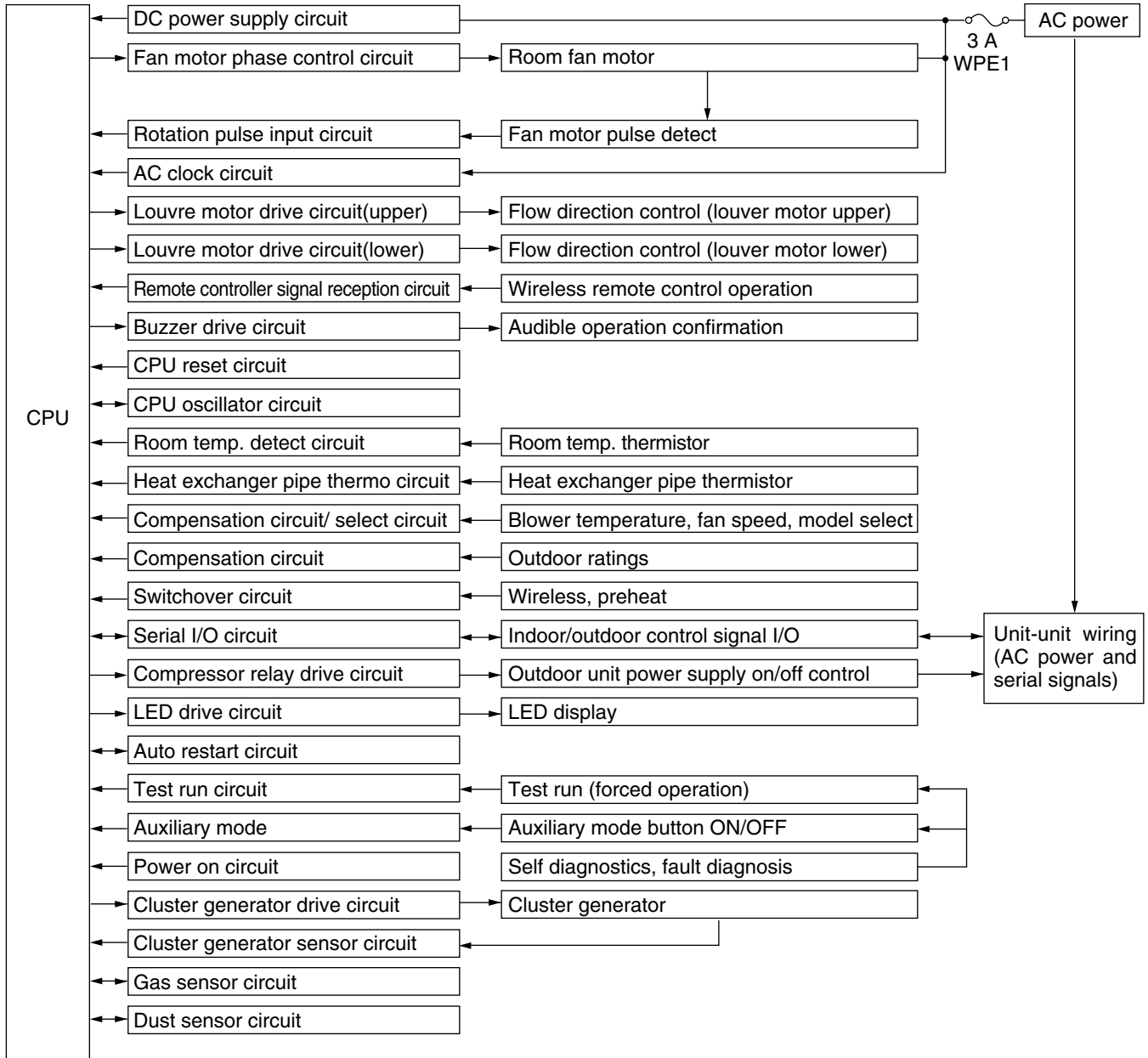

OUTDOOR UNIT for AE-X08BE-C/AE-X10BE-C

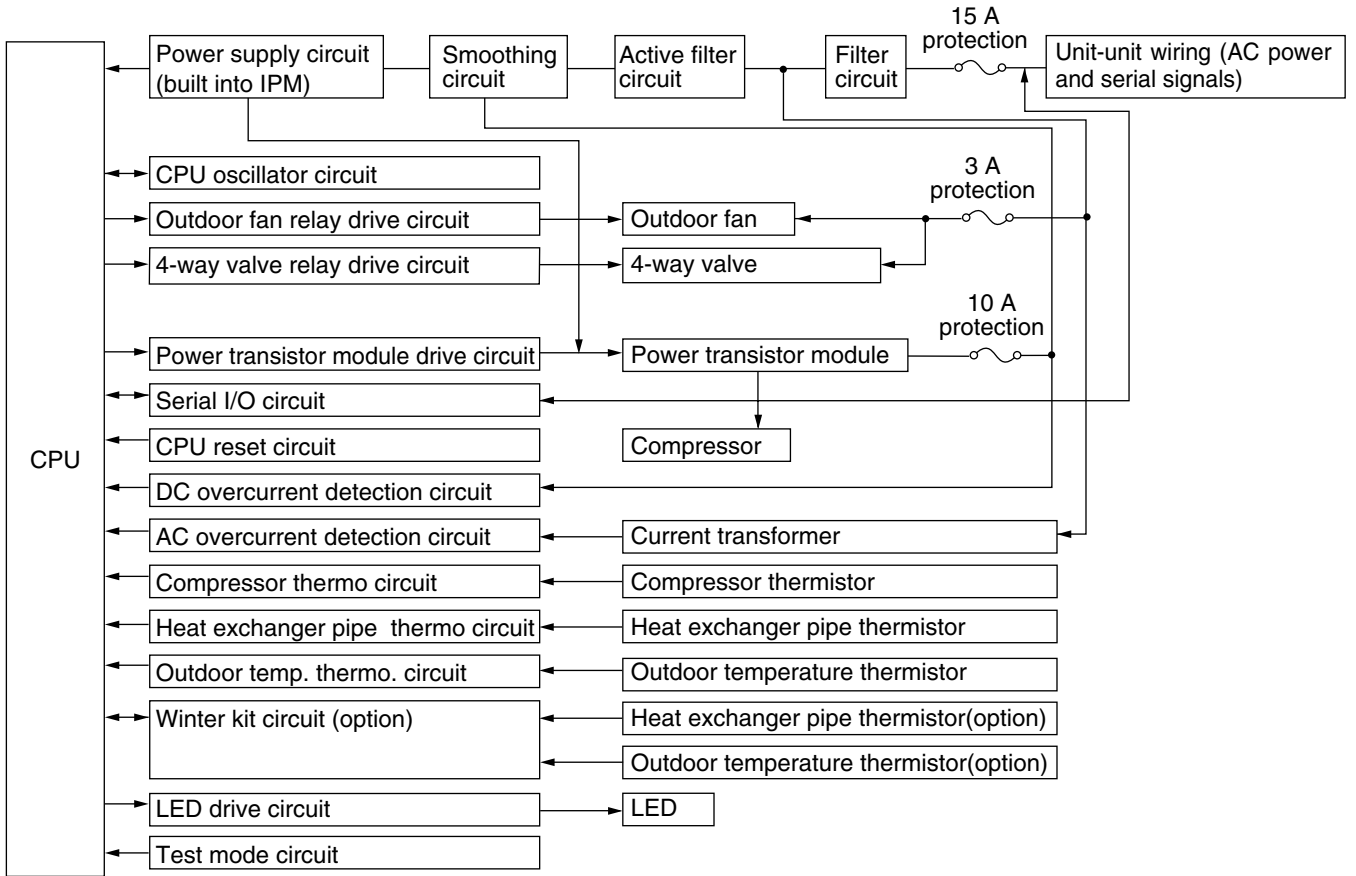

OUTDOOR UNIT for AE-X13BE

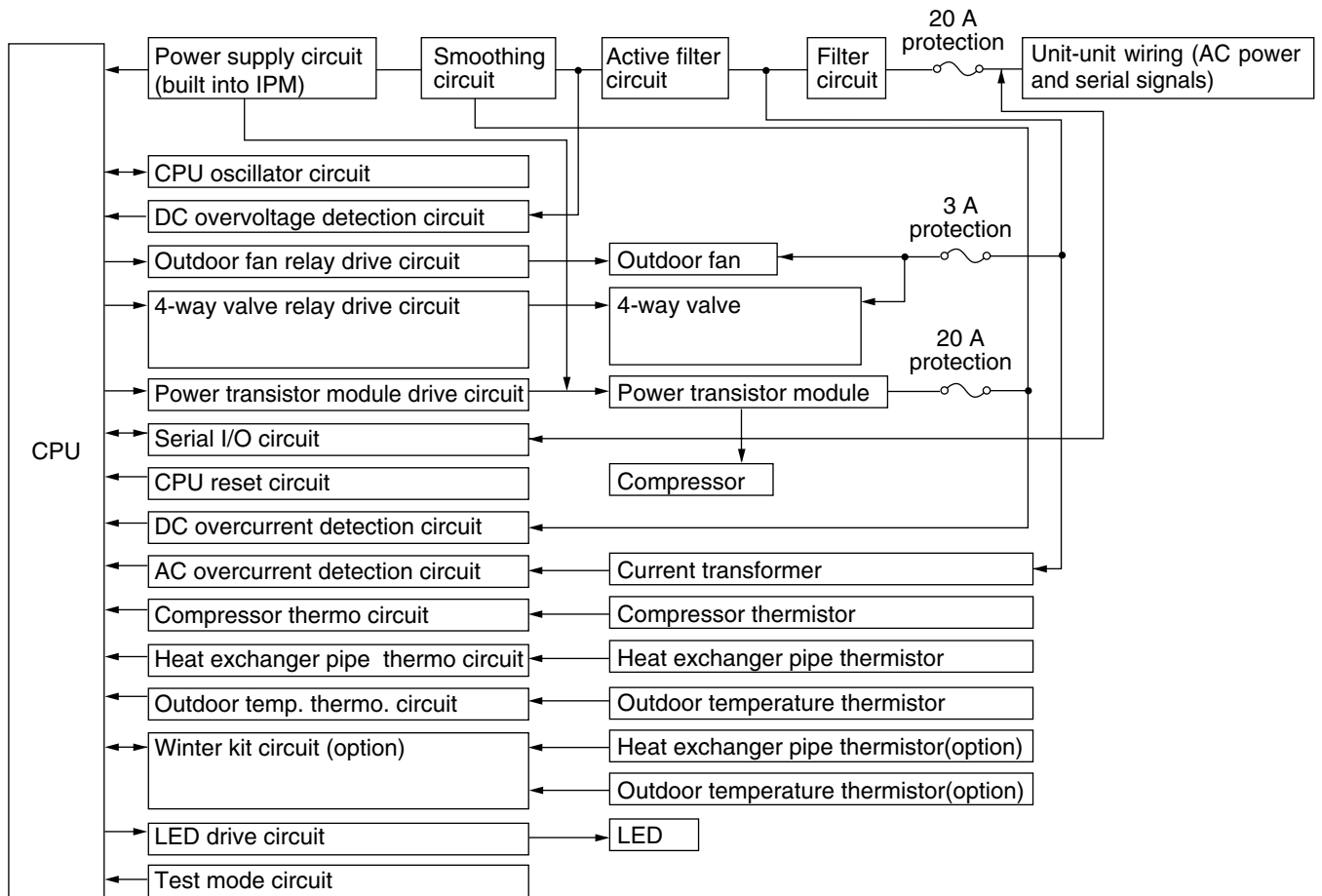

MICROCOMPUTER CONTROL SYSTEM

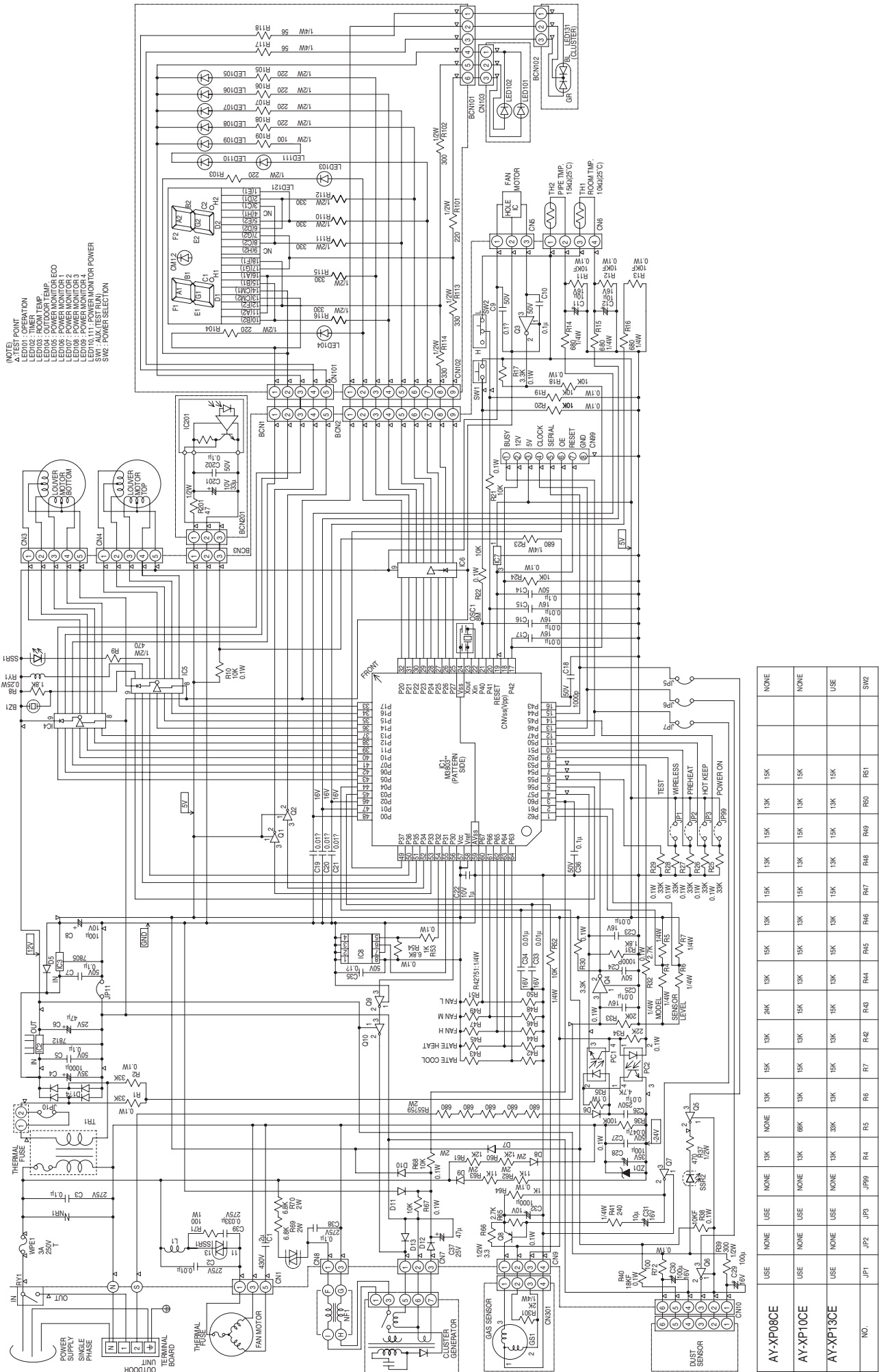

Figure L-1. Electronic Control Circuit Diagram for AY-XP08CE/XP10CE/XP13CE

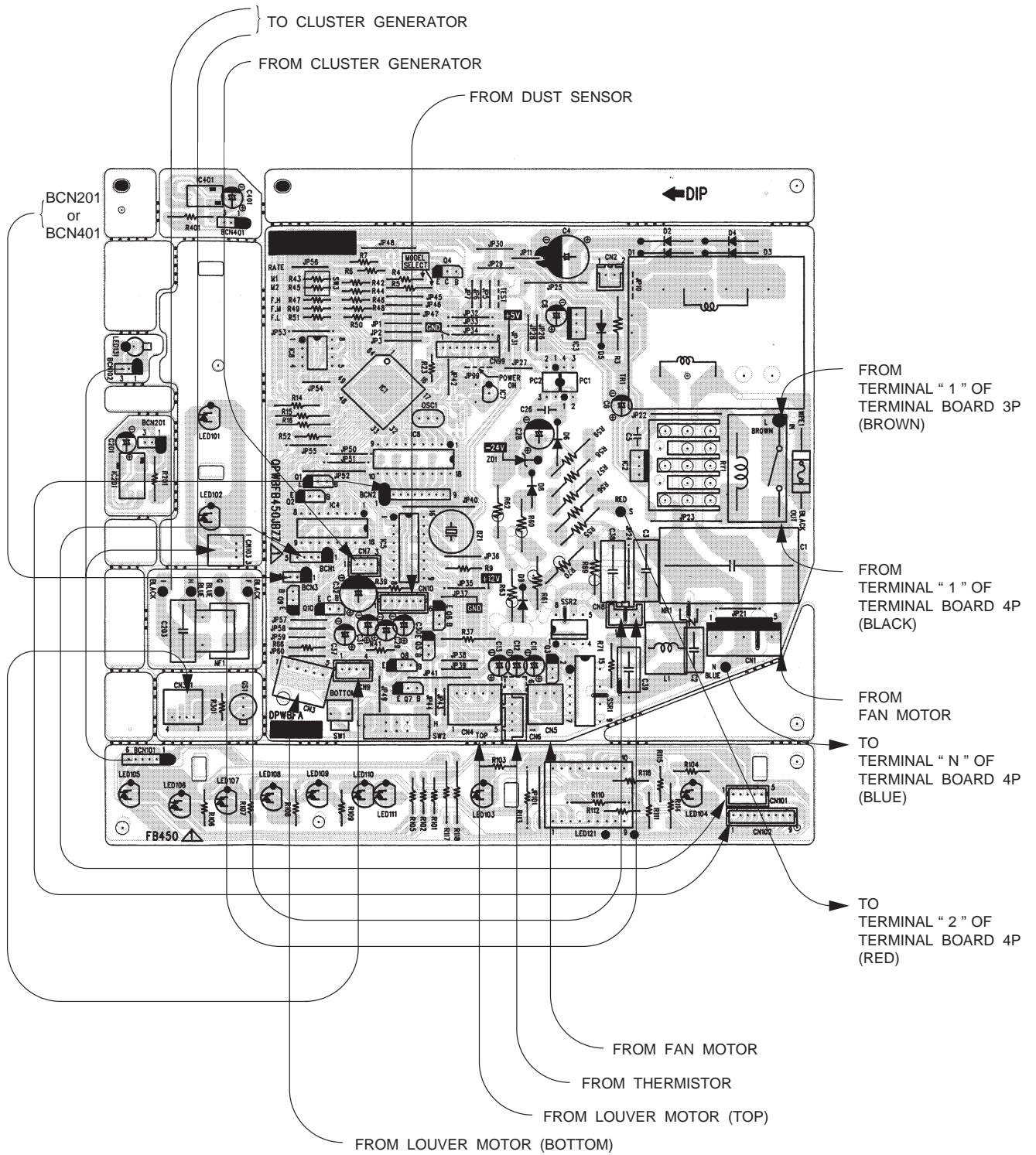

Figure L-2 Printed Wiring Board for AY-XP08CE/XP10CE/XP13CE

- NOTE
1. Δ MARK IS TEST POINT.
 2. \sim IF NOT SPECIFIED 1/4W (RESISTOR)

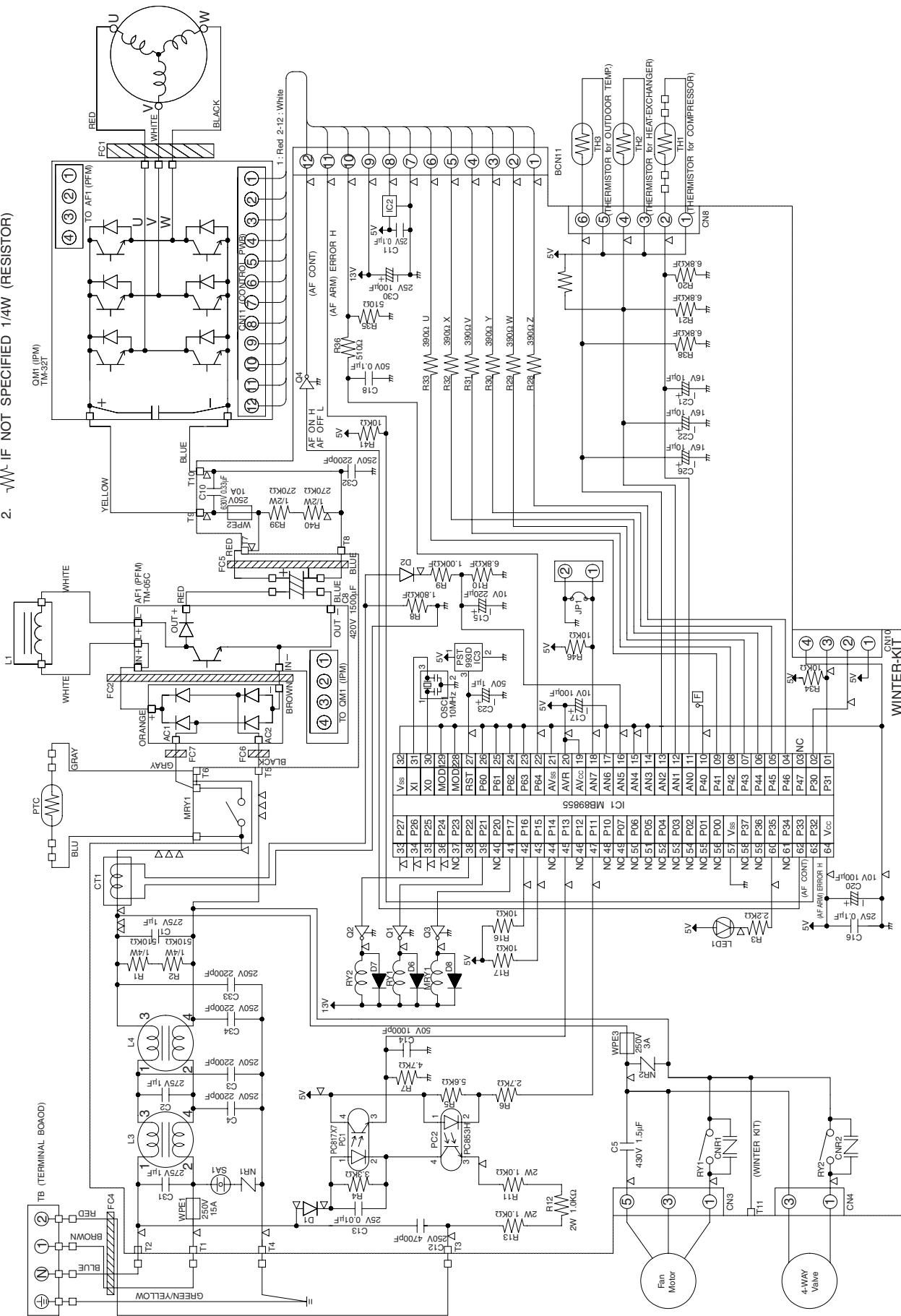

Figure L-3. Electronic Control Circuit Diagram for AE-X08BE-C/X10BE-C

- NOTE
1. Δ MARK IS TEST POINT.
 2. \sim IF NOT SPECIFIED 1/4W (RESISTOR)

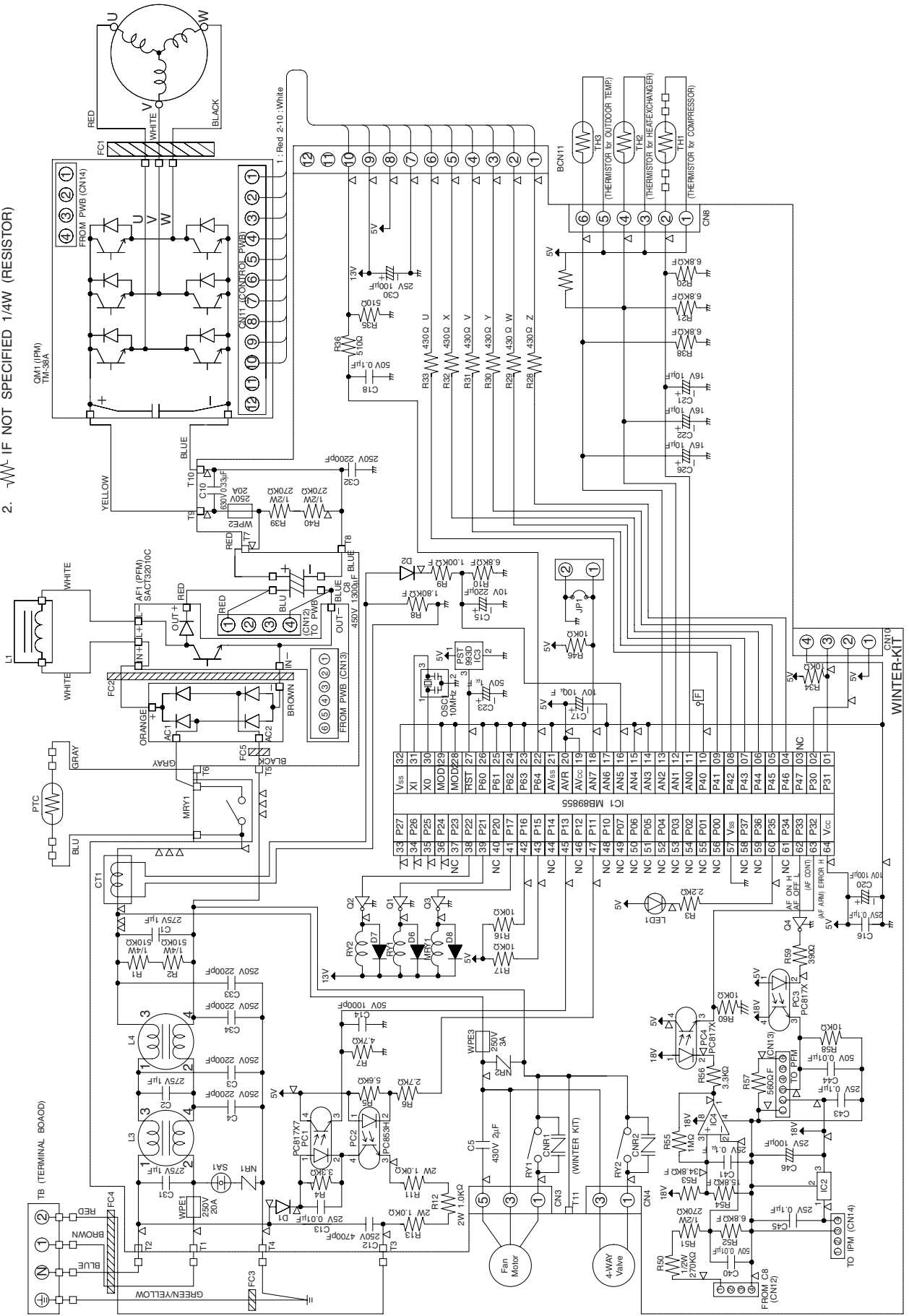

Figure L-4. Electronic Control Circuit Diagram for AE-X13BE

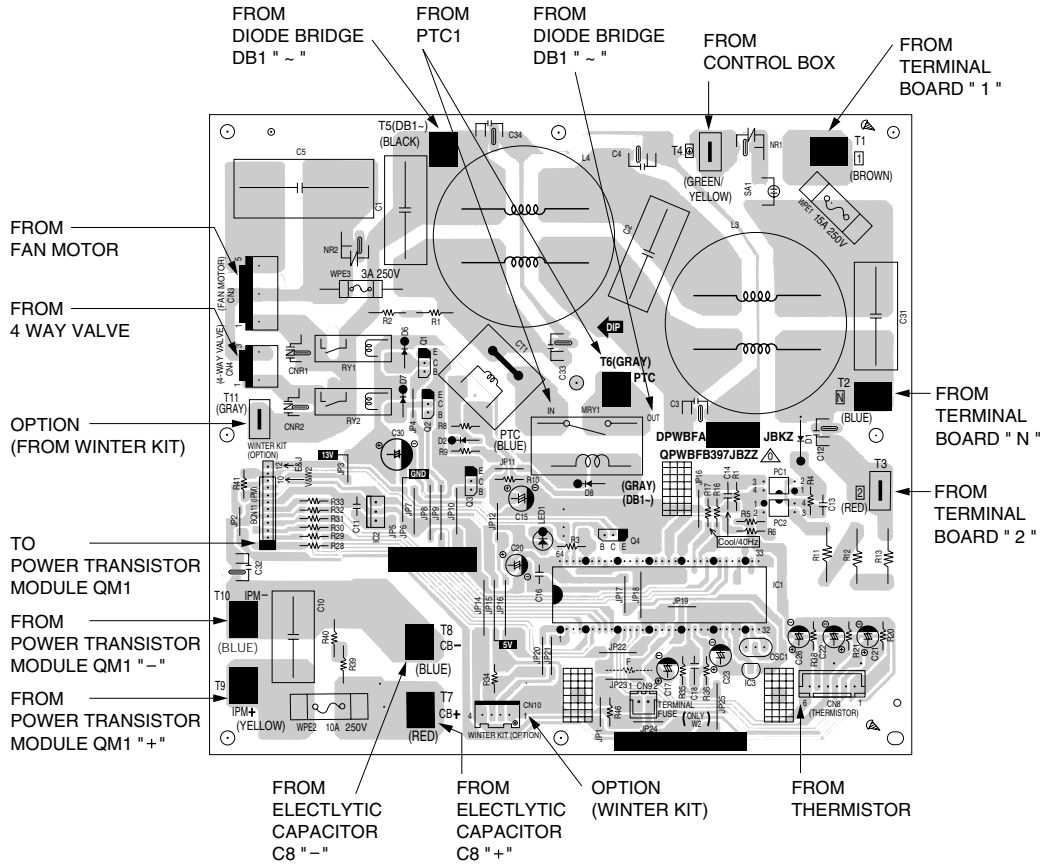

Figure L-5 Printed Wiring Board for AE-X08BE-C/X10BE-C

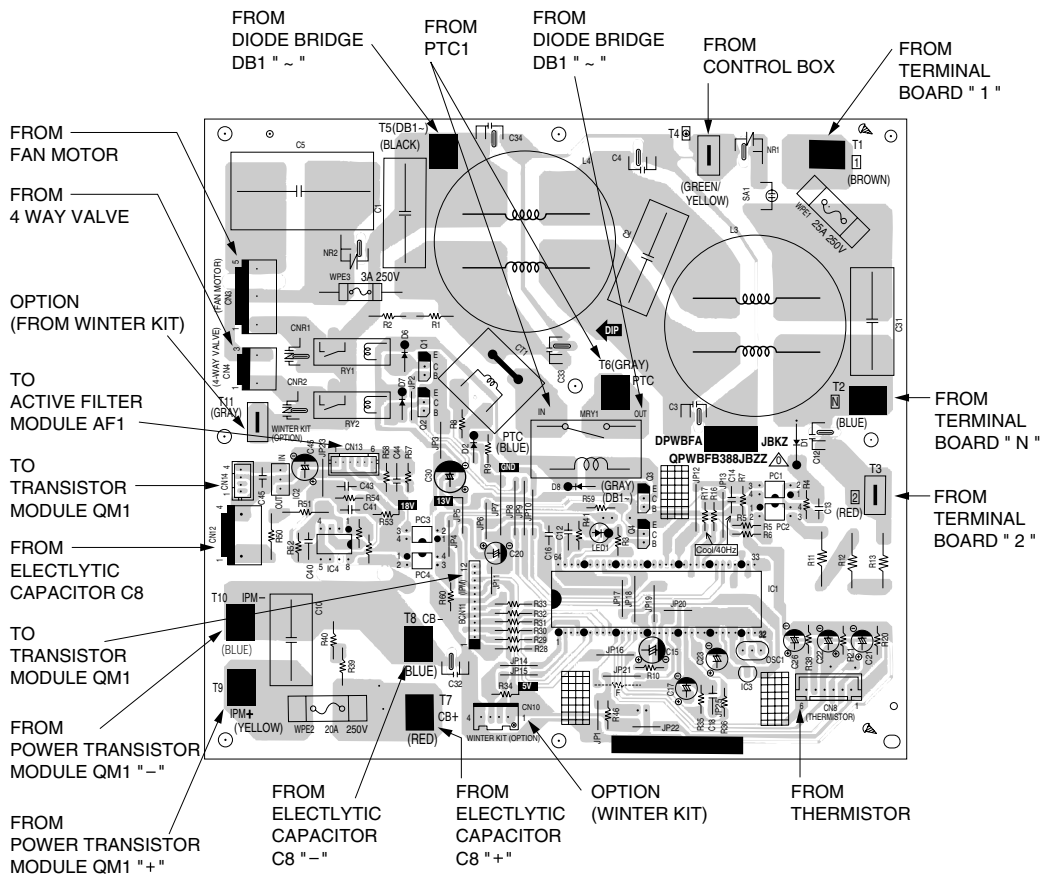

Figure L-6 Printed Wiring Board for AE-X13BE

FUNCTIONS

1. INDOOR UNIT

1-1 Temperature Adjustment

(1) Cooling

When the room temperature is higher than the preset temperature by 2°C or more, the unit runs at the maximum operation frequency until the temperature comes down to the preset temperature.

When reaching the preset temperature, the unit runs at the frequency calculated by the fuzzy operation and switches to the normal control.

(2) Heating

When the room temperature is lower than the preset temperature by 3.5°C or more, the unit runs at the maximum operation frequency until the temperature comes down to the preset temperature.

When reaching the preset temperature, the unit runs at the frequency calculated by the fuzzy operation and switches to the normal control.

(3) Dry

After operation begins, 2 minutes of the room temperature is stored in memory, and that becomes the set value.

1-2 Indoor fan control

(1) Cooling

The fan speed can be selected from "Auto", "Soft", "Low", and "High". When "Soft", "Low" or "High" is selected, the fan speed is constant regardless of the room temperature. When "Auto" is selected, the fan speed automatically changes between "Soft" and "High" depending on the difference

between the room and preset temperature.

Control for indoor freezing prevention

If the temperature of the indoor heat exchanger stays below approximately 1°C for four minutes during cooling or dry, this control stops the compressor. Over 3°C the compressor will run again.

(2) Heating

Control for cold air blowing prevention

When heating begins, this control stops the indoor

fan until the temperature of the indoor heat exchanger reaches 23°C. It also stops the fan if the temperature goes below 21°C during operation.

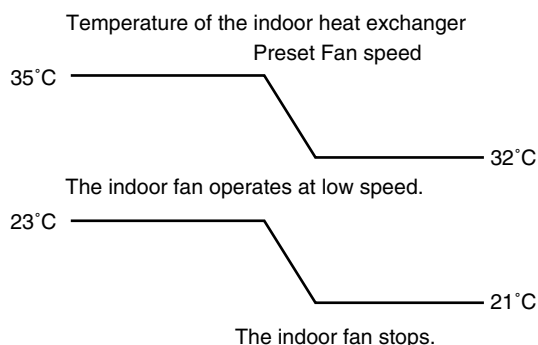

1-3 Hot keep

If the room temperature is in the j or k zone during heating, the compressor is turned on and off to prevent overheating.

The fan goes off 30 seconds after the compressor goes off.

Compressor intermittent time	Fan
3 min. on - 3 min. off	Same as Compressor
3 min. on - 8 min. off	After "3 min. on - 3 min.off" is repeated 4 times, the compressor goes off, and only the fan continues to repeat "3 min. on - 8 min.off".

1-4 Automatic operation

The operating mode and temperature setting are determined by the room temperature and the external air temperature.

The operating mode will changeover automatically with the following condition.

Room temperature (°C)	※ Outdoor temperature (°C)					
	0	10	18	28	34	
29	※ Cooling (26°C)	※ Cooling (25°C)	※ Cooling (24°C)	Cooling (24°C)	Cooling (25°C)	Cooling (26°C)
21	Heating (24°C)	Heating (23°C)	Heating (22°C)	(Dry) (Room temperature - 2°C)		

Room temperature (°C)

※ When the cooling operation only can use winter kit

1. From cooling to heating

Cooling mode will changeover to heating mode when condition of indoor temperature 1.7°C lower than the set temperature conditions for 5 minutes.

2. From heating to cooling

Heating mode will change over to cooling mode when condition of indoor temperature 1.3°C higher than the set temperature conditions for 25 minutes under Hot keep condition.

3. When the set temperature is adjusted within the range of ±2°C by the remote control's key.

(▼ ▲), the changeover judgement room temp. will also be shifted within the range of ±2°C.

1-5 ON-timer

The ON-timer is set by pressing the ON-timer button. In order to attain the set temperature at the set time, the operation starting time is corrected by neuro and fuzzy computing one hour before the set time.

1-6 OFF-timer

The OFF-timer is set by pressing the OFF-timer button. Operation is as follows:

	Set temperature
Cooling Heating	By fuzzy computing Set the shift up time Final (Cooling setting + 1°C) (Heating setting - 3°C)
Dry	Same as above (Final setting + 1°C)

*During Heating

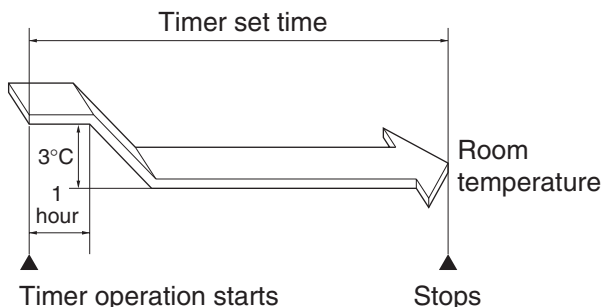

*During Cooling / Dry

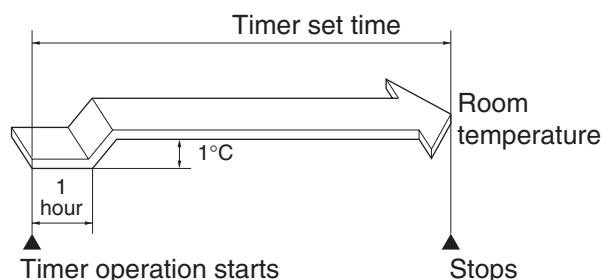

1-7 Swing louvre

The louvre is moved by a stepping motor to perform swing and fixing in the set position. If the "FLOW DIRECTION" button is pressed during swing, it will stop. If the "FLOW DIRECTION" button is pressed while it is stopped, it will swing. The vertical adjustment louvre will change its angle continuously. Press the SWING button again when the vertical adjustment louvre is at the desired position.

- The louvre will stop moving within the range shown in the diagram.
- The adjusted position will be memorized and will be automatically set to the same position when operated the next time.

Adjustment range

COOL and DRY modes HEAT and FAN ONLY mode

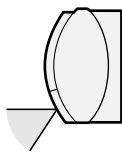

The adjustment range is narrower the SWING range in order to prevent condensation from dripping.

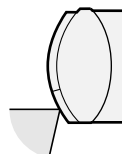

The range is wide so the air flow can be directed toward the floor.

1-8 One-hour operation

If this button is pressed when operation is stopped, operation will begin and then stop after 1 hour. If pressed when it is operating, will stop after one hour.

1-9 Full power operation

Immediately begins cooling or heating at maximum power and air flow.
 (During heating)
 Operates at setting of 32 °C.
 (During cooling)
 Operates at setting of 18 °C.

1-10 Power ON start

If a jumper wire is inserted into the place indicated JP99 on the indoor control board, and the power plug is inserted. cooling or heating will be automatically determined by the room temperature sensor on the main unit, and operation will begin.

1-11 Preheat

When heating is stopped, supplies a small amount of power to the compressor to make heating start more quickly. Operates when the indoor temperature sensor and external air sensor detect that the room temperature and outdoor temperature are low (below 18°C and 5°C, respectively). Stops when the compressor chamber temperature rises above 25°C. Preheat does not operate for 2 hours after heating is stopped. After that, it goes on for 180 minutes and then stops for 30 minutes, repeatedly.

1-12 Power selector (AY-XP13CE)

Operation power "H" (High) or "L" (Low) can be selected by switching the POWER SELECTOR slide switch located above the AUX. button.

	Power select	Cooling	Heating
AY-XP13CE	H	7.9A	10.5A
	L	6.1A	7.2A

1-13 Auto Restart

When power failure occurs, after power is recovered, the unit will automatically restart in the same setting which were active before the power failure.

Operating mode (Cool, Heat, Dry)

- Temperature adjustment (within 2°C range) automatic operation
- Temperature setting
- Fan setting
- Air flow direction
- Power ON/OFF
- Automatic operation mode setting
- Swing louvre

Setting not memorized

- Timer setting
- Full power setting

1-14 Indoor/outdoor temperature display

Every time the Temperature check button is pressed on the remote control, the display changes in the order of indoor temperature → outdoor temperature → no display. The temperature is displayed on the temperature indicator on the main unit to be referred to for energy saving.

(When the unit is not running, the display changes between indoor temperature and no display.) Indoor temperature is the temperature of the suction air measured by the room thermistor, and outdoor temperature is that measured by the outdoor temperature thermistor. When indoor temperature is displayed, the indoor LED on the main unit is lit, and when outdoor temperature is displayed, the outdoor LED is lit. For 90 seconds after the operation starts, - - is displayed instead of the actual outdoor temperature since it is still being measured. Because of the effect of the exchanger, the unit cannot confirm the exact indoor temperature right after the operation is terminated. Therefore, for one hour since the operation is stopped, the indoor temperature immediately before the operation is stopped is displayed. After over one hour since it is stopped, the unit displays the actual room temperature at that point.

1-15 Error diagnostic display

(a) Indoor unit

- (1) When an error is detected, all relays are turned off. At the same time, the details of the error are displayed by flashing the number corresponding to the type of the error. The details can also be displayed by pressing down the emergency operation switch for 5 seconds or more in the state of operation stop. However, if the operation is continued only in the serial open state and the state remains unchanged after that, the main relay is turned off in 8 minutes. In the serial short state, the error is not displayed and the operation is continued. If the unit stays in the same state, the main relay is turned off in 8 minutes. Although the error is not displayed, it is memorized and can be displayed when it is recalled.
- (2) If the operation is stopped and the emergency operation button is pressed down for 5 seconds or more, the self-diagnosis memory can be recalled.
- (3) Details of self-diagnosis (error mode) are informed by the flashing number as well as the lighting pattern of the operation lamp which flashes with the timer lamp. (For details, refer to Error diagnostic method.)

1-16 Compressor relay

- (1) It is ON during operation, and when operation is stopped, goes OFF after a delay of 100 seconds (not immediately).

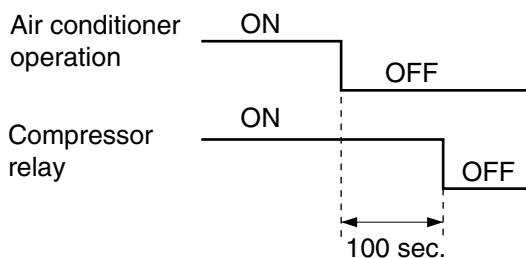

- (2) The minimum OFF time of the relay is 80 seconds. It will not go ON again before 80 seconds elapses.

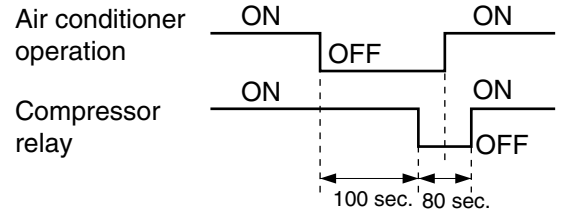

- (3) If air conditioner operation is turned on again during the 100 second delay before the compressor relay goes off, the compressor relay will stay on.

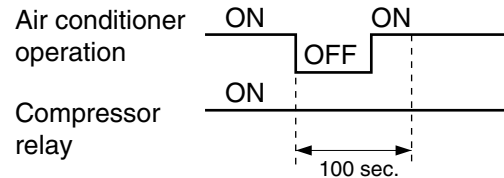

2. DESCRIPTION OF ODOR SENSOR

- (1) Outline of the odor sensor

The odor sensor is used to cluster display during operation. This odor sensor sensitively reacts to the various air contaminations such as a volatile organic solvent, fragrant materials and tobacco burning gas. In the figure on the right, RS indicates a sensor resistance, RL a load resistance, VRS a sensor output voltage, and VC a sensor power supply voltage. Their relation is expressed in the following formula. When the air contamination level increases, the value of the sensor resistance RS drops, which also lowers the value of the sensor output voltage.

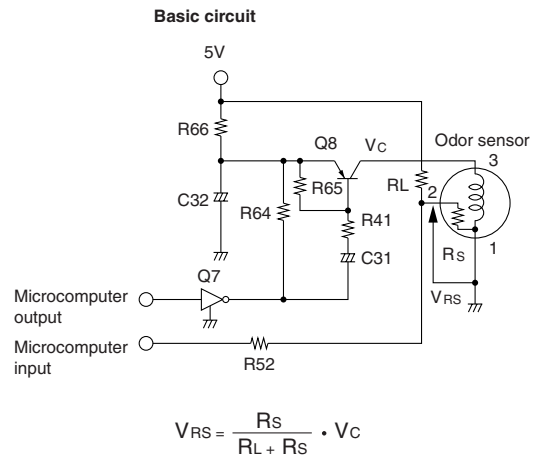

While detecting contamination, the microcomputer outputs the following pulse to the transistor Q8, which drives the heater with the built-in odor sensor using the pulse.

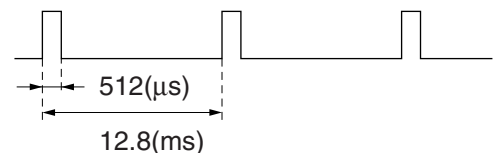

What to Odor Sensor react to ?

Odor Sensor also may react to vapour of insecticides, cosmetics, alcohol, hemicals and the like, and to extreme change of temperature / humidity.

(2) Detection of the air contamination by the fluctuation ratio of sensor resistance

The output voltage from the odor sensor is input into the microcomputer to detect the air contamination.

This method detects the air contamination by converting sensor output voltage into the sensor resistance value and calculating its fluctuation ratio per unit of time. Therefore, the sensor determines that the air is contaminated when the sensor resistance value drops abruptly.

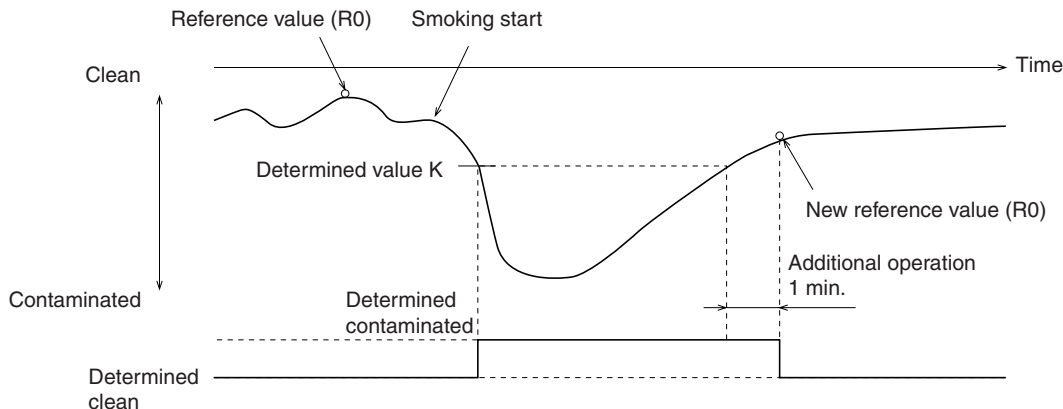

(3) Operation of the microcomputer

When the air conditioner is power on, the microcomputer starts operating and, after 1 minute, starts detecting the air contamination.

(4) Switching sensitivity of the odor sensor

The sensitivity of the odor sensor can be adjusted when the sensor is too responsive or unresponsive.

It is set as standard at the factory.

Sensitivity is divided into three levels: high, standard, and low.

The contamination is detected when the sensor resistance drops below following percentages compared to the reference value in a clean state.

(This is equal to the description of the resistance of the allergen sensor.)

	P.W.B.	
	R7	R6
High (85%)	15kΩ	—
Standard (80%)	15kΩ	13kΩ
Low (75%)	—	13kΩ

3. DESCRIPTION OF THE OPTIAL ALLERGEN SENSOR

(1) Outline of the optical allergen sensor

As with the odor sensor, this sensor is used to display cluster during the operation. The pulse signal is output from the microcomputer into the basic circuit show in the figure below, and the sensor signal is input into the microcomputer according to the size or amount of the dust.

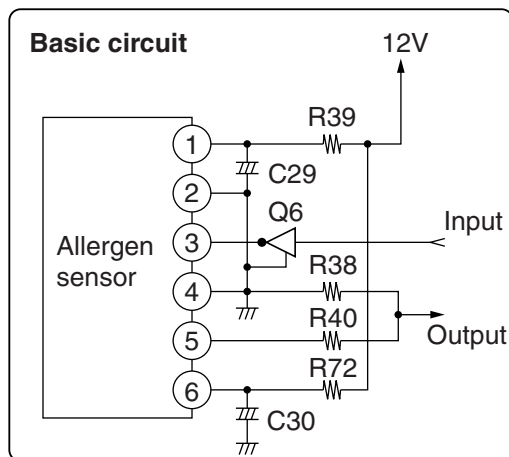
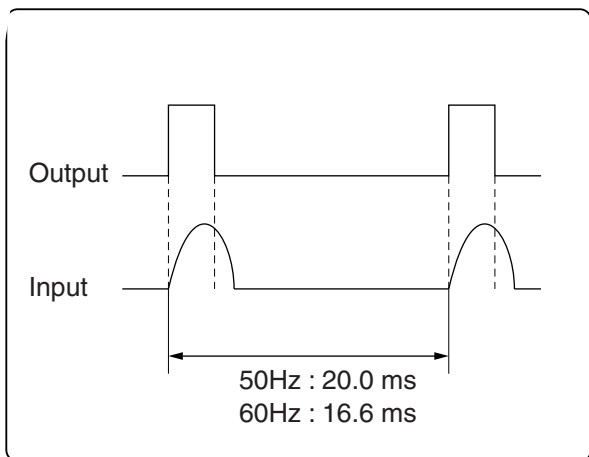

(2) Dust detection by using the sensor

The output voltage from the optical allergen sensor is input into the indoor unit's microcomputer to detect the air contamination (dust). This method inputs the sensor voltage per unit of time and calculates the relative fluctuation to determine whether the air is contaminated or not.

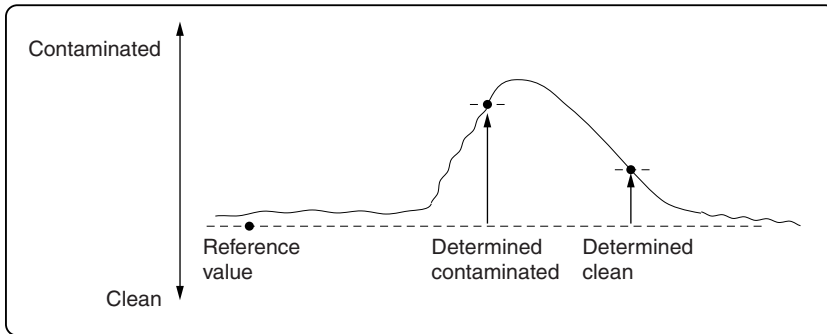

(3) Operation of the indoor unit's microcomputer

As with the odor sensor, the microcomputer starts constantly detecting the air contamination level after 1 minute of the operation start.

(4) Switching sensitivity of the optical allergen sensor

The sensitivity can be adjusted. However, both sensors will be adjusted to the same level.

The air contamination is detected in the following seconds at each sensor level.

	R7	R6
High (2 sec.)	15kΩ	—
Med (3 sec.)	15kΩ	13kΩ
Low (4 sec.)	—	13kΩ

TIPS ABOUT INDICATOR PANEL

The indicator panel will change each time you press the DISPLAY button in the following manner.

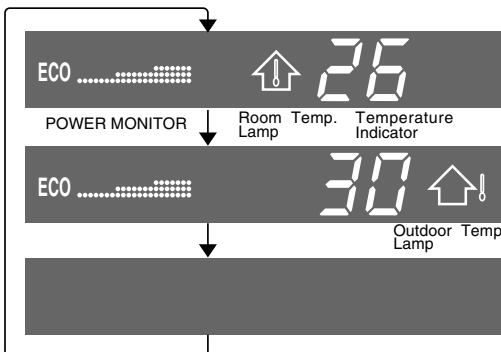
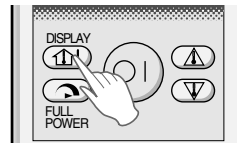

The room temperature and POWER MONITOR are displayed.

The outdoor temperature and POWER MONITOR are displayed.

No display.

POWER MONITOR

When the room temperature or the outdoor temperature is displayed, the POWER MONITOR will light up in 4 levels for COOL and HEAT modes (3 levels for DRY mode), to indicate the operation power. When the air conditioner is operating at maximum power in the COOL and HEAT modes, "Power" will light and "Eco" will turn off on the indicator panel.

NOTES:

- The displayed temperatures are rough estimates and may vary from the actual temperatures.
- Temperature display ranges
 Room temperature: 0°C ~ 40°C (L0 is displayed when less than 0°C and H , when higher than 40°C)
 Outdoor temperature: -9°C ~ 45°C (L0 is displayed when less than -9°C and H , when higher than 45°C)
- -- is displayed during the first 90 seconds of operation while the temperatures are being detected.
- Only the room temperature can be displayed for 5 seconds when the unit is not in operation.

PLASMA CLUSTER OPERATION

You can choose PLASMA CLUSTER AUTO OPERATION, AIR CLEAN OPERATION or REFRESHING OPERATION

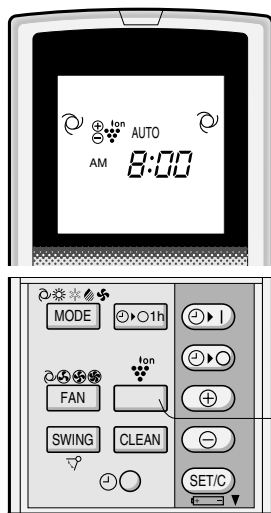

1 During operation, press the PLASMA CLUSTER button to select the mode.

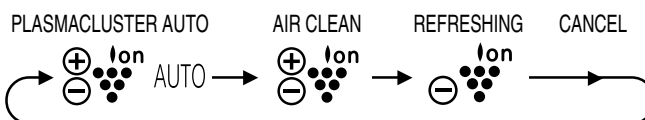

- In the AIR CLEAN operation, the blue PLASMA CLUSTER lamp on the unit will light up.
- In the REFRESHING operation, the green PLASMA CLUSTER lamp on the unit will light up.

TO CANCEL

Press the PLASMA CLUSTER button until PLASMA CLUSTER symbol on the remote control display goes off.

- The PLASMA CLUSTER lamp on the unit will turn off.

NOTES:

- Setting of the PLASMA CLUSTER operation will be memorized and will operate in the same mode, the next time you turn on the air conditioner.
- To turn off the PLASMA CLUSTER lamp, press the DISPLAY button.

SELF CLEAN OPERATION

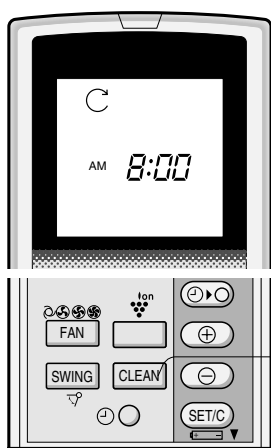

- The red OPERATION lamp () and the blue PLASMA CLUSTER lamp on the unit will light up.
- The unit will stop operation after forty minutes.
- The remaining operation time will be indicated on the TEMPERATURE INDICATOR of the indoor unit in minute decrements.

TO CANCEL

Press the SELF CLEAN button.
 Or, turn the unit off by pressing the ON/OFF button.

- The red OPERATION lamp (), the blue PLASMA CLUSTER lamp and the TEMPERATURE INDICATOR on the unit will turn off.

NOTE:

- You cannot set the temperature, fan speed, air flow direction or timer setting during the SELF CLEAN operation.

TIP ABOUT PLASMACLUSTER OPERATION

The ionizer inside the air conditioner will release cluster ions, which are collective mass of positive and negative ions, into the room. The cluster ions eliminate airborne mold fungus and deodorize / decompose odor-causing molecules.

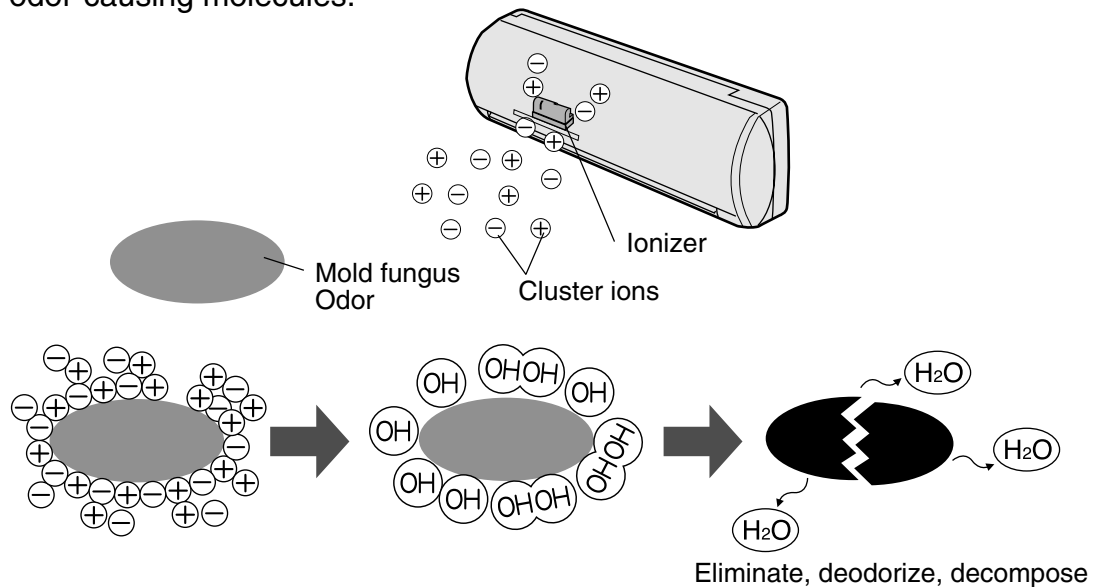

AIR CLEAN OPERATION

Cluster ions released into the air will keep your room air clean.

REFRESHING OPERATION

Negative cluster ions which also exist in natural environment will be released into the air of your room in an increased rate, and help your physical and mental refreshment.

PLASMACLUSTER AUTO OPERATION

Allergen sensor and odor sensor will detect foul air in the room.

Air Clean Operation will be performed for one minute after the air conditioner is operated to detect foul air.

Air Clean Operation and Refreshing Operation will be selected and be performed automatically depending on the air foul degree.

Air Clean Operation will be performed when the air is detected to be foul, Refreshing Operation will be performed when the air is clean.

SELF CLEAN OPERATION

Plasmacluster Operation will be performed with FAN or HEAT mode, in order to reduce the growth of mold fungus, and dry inside of the air conditioner unit.

Utilize the operation at seasonal change over terms.

Mold fungus already grown can not be eliminated by this operation.

TIPS ABOUT ALLERGEN SENSOR AND ODOR SENSOR

What does Allergen Sensor react to?

- Allergen sensor reacts to mold fungus, plants/flowers pollen, dead ticks, dust, tobacco smoke etc.

What to Odor Sensor react to?

- Odor Sensor reacts to tobacco smoke, motor exhaust, odor emitted from animals, etc.

Allergen and Odor Sensor also may react to vapour of insecticides, cosmetics, alcohol, chemicals and the like, and to extreme change of temperature/humidity.

2. OUTDOOR UNIT

2-1 Defrost operation

(AE-X08BE/X08BE-C/X10BE/X10BE-C/13BE)

(1) Overview

Defrosting begins during heating if the conditions for compressor operation time and outdoor heat exchanger temperature are met.

When defrosting begins, the indoor and outdoor fans stop. Defrosting stops when the temperature of the outdoor heat exchanger goes above approximately 5°C or defrosting time exceeds 13 minutes.

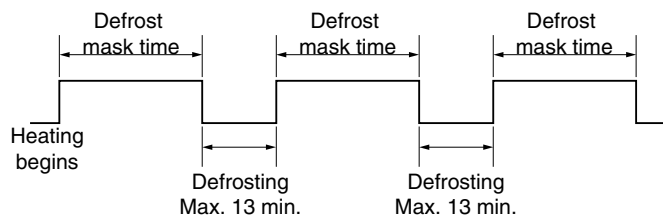

2) Defrosting

If the compressor operation time is more than 20 minutes in the heating mode and the outdoor air temperature and outdoor heat exchange temperature satisfy the defrosting conditions, the defrosting operation is started.

When the outdoor sheat-exchanger temperature reaches approx. 5°C or above or when the defrosting time exceeds 12 minutes, the defrosting operation is quit.

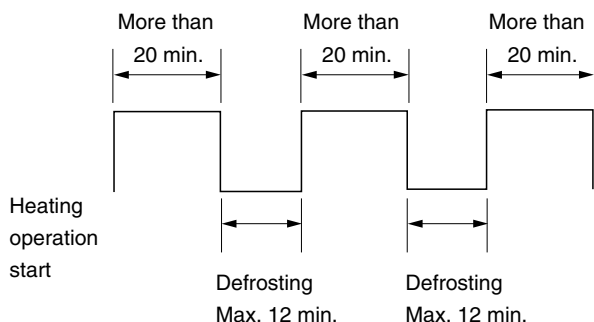

(3) During defrosting

When defrosting begins, the compressor stops. Approximately 1 minutes later, the compressor reactivates in the refrigeration cycle, and the outdoor heat exchanger is defrosted.

Each mode is as follows:

The outdoor fan is stopped

The operating frequency is as shown in the table below The indoor fan is stopped

(4) Defrost stop

When defrosting time exceeds 13 minutes When the temperature of the outdoor heat exchanger rises above approximately 5°C Defrost stop is determined by either of the above conditions, and the compressor is stopped. At the same time, the outdoor fan go ON. The compressor is reactivated in the heating cycle 1 minute after it was stopped, and normal control resumes.

2-2 Frequency control

Model	Set value	
	Cool	Heat
AE-X08BE-C	5.3A	5.4A
AE-X10BE-C	6.2A	6.7A
AE-X13BE	7.9A	10.5A

(1) AC current peak control

(2) Control for prevention of indoor heat exchanger overheating. If the temperature of the indoor heat exchanger exceeds the overheating prevention line 1 or 2 during heating, the operating frequency is lowered by approximately 5 to 10 Hz. After that, the frequency is lowered by approximately 5Hz once every 60 seconds or 10 Hz once every 120 seconds. When the temperature of the indoor heat exchanger goes below the overheating prevention line 1, the frequency is raised by approximately 5 Hz once every 60 seconds, and normal operation is restored. If the frequency is lowered to minimum frequency without the temperature of the outdoor heat exchanger decreasing and this condition lasts for 1 minute, the compressor will be stopped.

Frequency	A	B	C	D	E	F	G
AE-X13BE	120	113	107	100	50	43	37
AE-X08BE-C	101	100	90	85	50	45	40
AE-X10BE-C	114	109	103	97	50	43	37

Overheating prevention line 1(Lower 5Hz)									
Operating Frequency		A~	A~B	B~C	C~D	D~E	E~F	F~G	~G
During normal operation	[°C]	46.11	49.59	51.87	53.29	54.26	53.29	52.34	51.41
During full power operation	[°C]	49.14	51.87	54.75	56.25	58.32	56.76	55.74	54.26
Overheating prevention line 2(Lower 10Hz)									
Operating Frequency		A~	A~B	B~C	C~D	D~E	E~F	F~G	~G
During normal operation	[°C]	48.26	51.87	51.87	55.24	56.25	55.24	54.26	53.29
During full power operation	[°C]	51.41	51.87	53.77	58.32	59.94	58.32	57.27	56.25

- (3) Control for prevention of outdoor heat exchanger overheating. If the temperature of the outdoor heat exchanger exceeds the overheating prevention line 1 or 2 during cooling, the operating frequency is lowered by approximately 5 to 15 Hz.

After that, the frequency is lowered by approximately 5 once every 60 seconds or approximately 15Hz once every 120 seconds. When the temperature of the outdoor heat exchanger goes below the overheating prevention clear line, the frequency is raised by approximately 5 Hz once every 60 seconds, and normal operation is restored. If the frequency is lowered to minimum frequency without the temperature of the outdoor heat exchanger decreasing and this condition lasts for 1 minute, the compressor will be stopped.

Overheating prevention line 1	56°C	Lower 5Hz once every 60 seconds
Overheating prevention line 1	58°C	Lower 15Hz once every 120 seconds
Overheating prevention line 1	55°C	

- 4) Control for prevention of discharge overheating
 If the discharge temperature exceeds approximately 105°C during compressor operation, the operating frequency is lowered by approximately 5 Hz. After that, the frequency is lowered by approximately 5 Hz once every 60 seconds. When the discharge temperature goes below approximately 104°C, the frequency is raised by approximately 5 Hz once every 60 seconds, and normal operation is restored.
 If the frequency is lowered to minimum frequency without the discharge temperature decreasing and this condition lasts for 1 minute, the compressor will be stopped.
- (5) Control for prevention of indoor heat exchanger freezing
 If the temperature of the indoor heat exchanger goes below approximately 5°C during cooling(only Full power operation), the operating frequency is lowered by approximately 5 Hz. After that, the frequency is lowered by approximately 5 Hz once every 60 seconds. When the temperature of the indoor heat exchanger rises above approximately 5°C, the frequency is raised by approximately 5 Hz once every 60 seconds, and normal operation is restored.
 If the temperature of the indoor heat exchanger goes down to approximately 0°C and this condition continues for 4 minutes, the compressor is stopped.
 When the temperature rises above approximately 2°C, normal operation is restored.

2-3 Overcurrent protection

- (1) Compressor lock detection
 If the set value 2.7A of AC current is exceeded in 6 seconds when operation begins, operation is stopped. In this case, the compressor outdoor fan does not stop, and 170 seconds after operation is stopped, another try will be made. Three retries are allowed. On the fourth retry, a complete stop request signal is sent to the indoor unit, and the outdoor unit will remain stopped until reset is performed. At this time, the 3-minute delay for control of the outdoor unit will not function; therefore, do not cancel by removing the plug and cutting the power.
- (2) DC overcurrent detection, AC overcurrent detection
 To protect against overcurrent due to sudden changes in load, the compressor is stopped if the set value (AE-X08BE-C/X10BE-C: 26A), (AE-X13BE: 47A) DC is exceeded in the DC section, or the set value (AE-X08-C/10BE-C: 11A, AE-X13BE: 13A) AC is exceeded in the AC section. In this case, the outdoor fan does not stop, and 170 seconds after operation is stopped, another try will be made. Three retries are allowed. On the fourth retry, a complete stop request signal is sent to the indoor unit, and the outdoor unit will remain stopped until reset is performed. At this time, the 3-minute delay for control of the outdoor unit will not function; therefore, do not cancel by removing the plug and cutting the power.

2-4 Compressor protector control

If the temperature of the compressor chamber exceeds 114°C, the compressor is stopped. In this case, the outdoor fan does not stop, and when the compressor chamber temperature decreases to 100°C three minutes after operation is stopped, another try will be made. Three retries are allowed. On the fourth retry, a complete stop request signal is sent to the indoor unit, and the outdoor unit will remain stopped until reset is performed. At this time, the 3-minute delay for control of the outdoor unit will not function; therefore, do not cancel by removing the plug and cutting the power.

2-5 Power transistor module protector

If the temperature of the chips in the power transistor module exceeds 105 °C, the compressor is stopped. In this case, the outdoor fan does not stop, and when the temperature of the chips in the power transistor module decreases to 105 °C 170 seconds seconds after operation is stopped, another try will be made. Three retries are allowed. On the fourth retry, a complete stop request signal is sent to the indoor unit, and the outdoor unit will remain stopped until reset is performed. At this time, the 3-minute delay for control of the outdoor unit will not function; therefore, do not cancel by removing the plug and cutting the power.

2-6 Power factor module

(AE-X08BE-C / AE-X10BE-C)

If a voltage error (over 400 V), current error (over 17 A), or temperature error (over 90°C) is detected in the power factor module, 170 seconds the compressor is stopped.

(AE-X13BE)

If a voltage error (over 420V) is detected at power factor module output voltage, 170seconds the compressor is stopped.

In this case, the outdoor fan does not stop, and 170 seconds after operation is stopped, another try will be made. Three retries are allowed. On the fourth retry, a complete stop request signal is sent to the indoor unit, and the outdoor unit will remain stopped until reset is performed. At this time, the 3-minute delay for control of the outdoor unit will not function; therefore, do not cancel by removing the plug and cutting the power.

2-7 Serial signals

- (1) Serial signals consist of all 96-bit signals.
- (2) If the outdoor unit does not receive a serial signal, it will stop approximately 30 seconds later. Note that this is true only of normal operation; in test mode, it does not stop and operation takes place based on the test mode commands.

FUNCTION AND OPERATION OF PROTECTIVE PROCEDURES

NO	Function	Operation				Self diagnostic display	
		Description	Detection time	Restart condition	Restart times	Indoor	Outdoor
1	Indoor fan lock	Stops operation if no revolution pulse signal is input from the indoor fan motor for one minute.	When indoor fan is revolving	Operation OFF	No limit	Yes	No
	Indoor fan rpm error	Stops operation if the revolution pulse signal from the indoor fan indicates low rpm (approximately 300 rpm or less).					
2	Indoor freezing guard	Lowers the operating frequency if the temperature of the indoor heat exchanger goes below 5°C during cooling. Stops the compressor if the temperature stays below 0°C for 4 minutes.	During cooling and dry	Automatically restarts when the exchange temperature rises above the freezing prevention temperature (above 2°C)	No limit	No	No
3	Indoor overheating control	Lowers the operating frequency if the temperature of the indoor heat exchanger rises above the overheating temperature during heating. Stops the compressor if the temperature stays above the overheating temperature for 1 minute at minimum frequency or less. Set values for overheating temperature During normal operation: 46°C to 54°C During full power operation: 49°C to 58°C	During heating	Automatically restarts when the exchange temperature goes below the overheating temperature.	No limit	No	No
4	DC overcurrent	Stops the compressor if a current of approximately 47/26A or more flows in the power transistor module. Also stops the compressor if the temperature of the power transistor module is exceeds 105°C.	During compressor operation	Automatically restarts after safety time (170 seconds)	8 times	Yes	Yes
5	AC overcurrent	Lowers the operating frequency if the compressor AC current exceeds set valve(*). Show "2-2(1)AC peak control" Stops the compressor if the current exceeds at 40Hz or less set valve(*).	During compressor operation	Automatically restarts after safety time (170 seconds)	4 times	Yes	Yes
6	Compressor lock	Stops the compressor if the compressor AC current exceeds (AE-X08BE-C/AE-X10BE-C: 26A, AE-X13BE: 47A) immediately after activating the compressor (in 6 seconds).	Immediately after compressor activation.	Automatically restarts after safety time (170 seconds)	4 times	Yes	Yes

(*)

Model	Set valve	
	Cool	Heat
AE-X08BE-C	5.3A	5.4A
AE-X10BE-C	6.2A	6.7A
AE-X13BE	7.9A	10.5A

NO	Function	Operation				Self diagnostic display	
		Description	Detection time	Restart condition	Restart times	Indoor	Outdoor
7	Compressor overheating control	Lowens the operating frequency if the temperature of the compressor chamber thermistor (TH1) rises above 105°C or 101°C. Stops the compressor if the thermistor stays above 105°C or 101°C for 1 minutes at minimum frequency or less.	During compressor operation	Automatically restarts after safety time (170 seconds)	No limit	No	No
8	Compressor high temperature error	Stops the compressor if the compressor chamber thermistor is above 114°C. (Or when TH1 shorts)	During operation	Automatically restarts when thermistor (TH1) temperature falls below 100°C (approximately 30 minutes)	4 times	Yes	Yes
9	Outdoor heat exchanger overheating control	Lowens the operating frequency if the temperature of the outdoor heat exchanger rises above 56°C during cooling. Stops the compressor if the temperature stays above 56°C for 1 minute at minumum frequency.	During compressor operation	Automatically restarts after safety time (170 seconds)	No limit	No	No
10	Outdoor thermistor short	Stops the compressor if an outdoor thermistor (excluding TH1) shorts.	When compressor is activated	Automatically restarts after safety time (170 seconds)	4 times	Yes	Yes
11	Outdoor thermistor open	Stops the compressor if the circuit of an outdoor thermistor breaks.	When compressor is activated	Automatically restarts after safety time (170 seconds)	4 times	Yes	Yes
12	AC abnormal current error	Stops the compressor if if the operating frequency is above 70 Hz and the compressor current is below 1.0 A.	During compressor operation	Automatically restarts after safety time (170 seconds)	4 times	Yes	Yes
13	Serial signal error	Turns the compressor relay off if the indoor unit does not receive a serial signal from the outdoor unit for 8 minutes.	During operation	Automatically restarts less than 8 minutes after operation stops	No limit	Yes	—
		Stops the compressor if the outdoor unit does not receive a serial signal from the indoor unit for 30 seconds.	During operation	Restarts after reception of serial signal	No limit	—	Yes
14	Power factor module (Active filter) error	When an power factor module error input is detected.	During compressor operation	Automatically restarts after safety time (170 seconds)	4 times	Yes	Yes

BREAK DOWN DIAGNOSIS PROCEDURE

Self-diagnostic procedure using display mode

If the timer lamp blinks during operation, the problem can be diagnosed using the following table.

● : Blinks at 2-second intervals × : OFF ○ : ON ⊙ : Blinks 3 times at 0.2-second intervals

Condition of indoor and outdoor unit	Display by indoor unit operation lamp				Display by outdoor unit lamp LED 1	Diagnosis	What to check, procedure	Solution
	Displayed in a pattern which comes on at the same time as the timer lamp	→ ○ × ○ × ○ × ○ × ○ × ○ → 4 seconds off	□	4				
Normal	×	×	×	×	●	Normal		
Indoor and outdoor unit completely stopped	×	×	○	×	⊙	Compressor lock error	Does compressor active ? Does it go off immediately after active ?	1. Apply an external shock to the compressor. 2. Replace the compressor.
	×	×	×	○	⊙	Overheat of the compressor error (protector operating) or outdoor compressor thermistor TH1 short	1. Is the discharge outlet of the outdoor unit clogged ? 2. Is the power supply voltage at least 198 V at full power operation ? 3. Check for refrigerant leaks at the tubing connections. 4. Measure the resistance of compressor thermistor TH1 on the outdoor unit (see Figure 2). 5. Measure the resistance of heat exchanger pipe thermistor TH2 on the indoor unit (see Figure 1).	1. Clear the discharge outlet. 2. Assure power supply voltage. 3. Refill to rated amount. 4. Replace the outdoor thermistor assembly. 5. Replace the indoor control board assembly or only TH2.
	×	×	○	○	⊙	DC overcurrent error	1. Check the circuit in the power transistor module. 2. Is the outdoor fan revolving ?	1. Replace power transistor module
	×	×	×	○	⊙	Short circuit of the thermistor error	1. Measure the resistance of thermistor TH2 on the outdoor unit (see Figure 2).	1. Replace the outdoor thermistor assembly.
	×	×	○	○	⊙	Open circuit of the thermistor error	1. Are the connectors of the outdoor unit thermistors well attached ? 2. Measure the resistance of thermistors TH1 and TH2 on the outdoor unit (see Figure 2).	1. Reattach. 2. Replace the outdoor thermistor assembly.
	×	×	×	○	⊙	AC abnormal current error	1. Can voltage be detected at the current transformer on the outdoor unit control board?	1. Replace the outdoor control board assembly (Current transformer wire break.)
	×	×	○	○	⊙	AC overcurrent error	1. Is the discharge outlet of the outdoor unit clogged ?	1. Clear the discharge outlet.
	×	○	○	○	⊙	Power factor module error	1. Check wiring of power factor module.	1. Replace the power factor module. 2. Replace C8. (※)

※ In cases when power supply voltage waveshape distortion is large, it can be improved by increasing the capacitance of capacitor C8.

C8 : → RC-AZA046JBE0 (1500µF 420V)
Capacitor clamp : → LBNDKA099JBWZ (Same for AE-X13BE)

● : Blinks at 2-second intervals ✕ : OFF ○ : ON ◎ : Blinks 3 times at 0.2-second intervals

Condition of indoor and outdoor unit	Display by indoor unit operation lamp				Display by outdoor unit lamp LED 1	Diagnosis	What to check; procedure	Solution
	Displayed in a pattern which comes on at the same time as the timer lamp							
Indoor unit operating Outdoor unit completely stopped	○	✕	○	○	✕	Indoor fan out of order	1. Is the fan motor locked? 2. Is the wiring connector firmly fitted? 3. Is the rotation pulse signal applied to the motor?	1. Replace fan motor 2. Reattach. 3. Replace the indoor control board assembly.
	○	✕	○	✕	○	Serial short	1. Check the wiring between units.	1. Rewire.
	○	✕	✕	○	○	Serial open	1. Check the wiring between units.	1. Rewire.
Indoor unit operating Outdoor unit completely stopped	○	✕	✕	○	✕	Outdoor power supply doesn't turn on. Wiring mistake.	1. Check the wiring between units. 2. Check the fuse in the outdoor unit. 3. Indoor control board. 4. Outdoor control board.	1. Rewire. 2. Replace the fuse, replace the outdoor board assembly. 3. Replace the control board. 4. Replace the control board.
	○	✕	○	✕	●	Cluster generator circuit error	1. Check the wiring between parts. 2. Indoor control board. 3. Hi-voltage unit.	1. Rewire. 2. Replace the control board. 3. Replace the Hi-voltage unit.

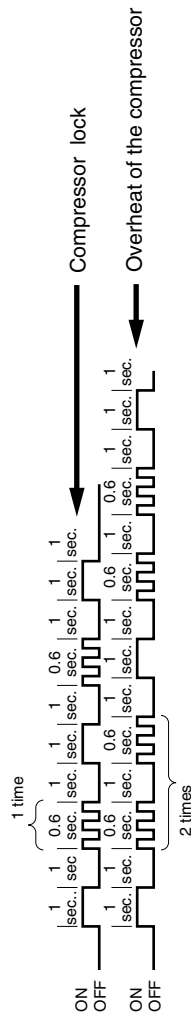

Note: 1. Normal : Only the timer lamp blinks. Error : Displayed by blinking of run lamp (above table).
 2. If the power plug is removed from the outlet or the breaker is switched to "OFF", the self-diagnostic memory will be erased.
 3. Example of outdoor unit LED 1 blinking :

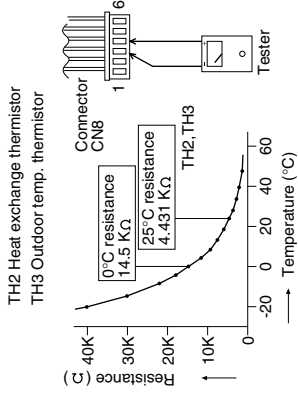

Figure 1 Temperature properties of indoor thermistors

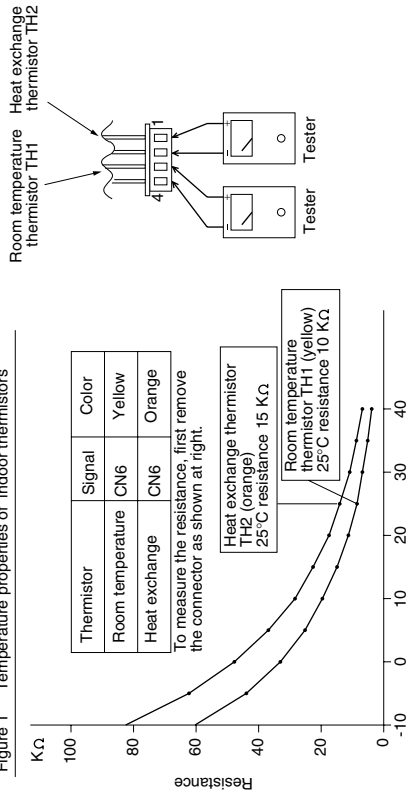

Figure 2 Temperature properties of outdoor thermistors

To measure the resistance, first remove the connector from the board.

Thermistor	No.	Connector	Color
Compressor thermistor	TH1	No. 1 to 2	Red
Heat exchanger pipe thermistor	TH2	No. 3 to 4	Orange
Outdoor temp. thermistor	TH3	No. 5 to 6	Green

Cautions when attaching or removing the board

When operating only the outdoor unit (cooling 40 Hz fixed mode) To make only the outdoor unit run in cooling mode, short the places marked with arrows below with an adaptor, and apply a voltage of 220 ~ 240 V AC to 1 and N on the terminal board.
 (Avoid operating the outdoor unit alone for long periods of time.)

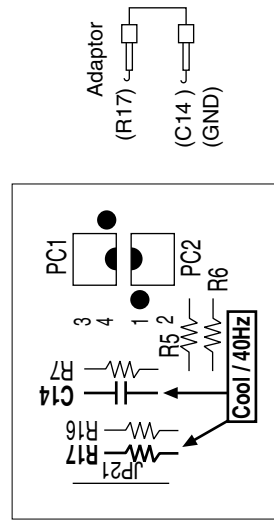

Microcomputer terminal	Input signal
Pin No. 43	0 Low input
Pin No. 42	1 High input

To Outdoor control board

REFRIGERATION CYCLE

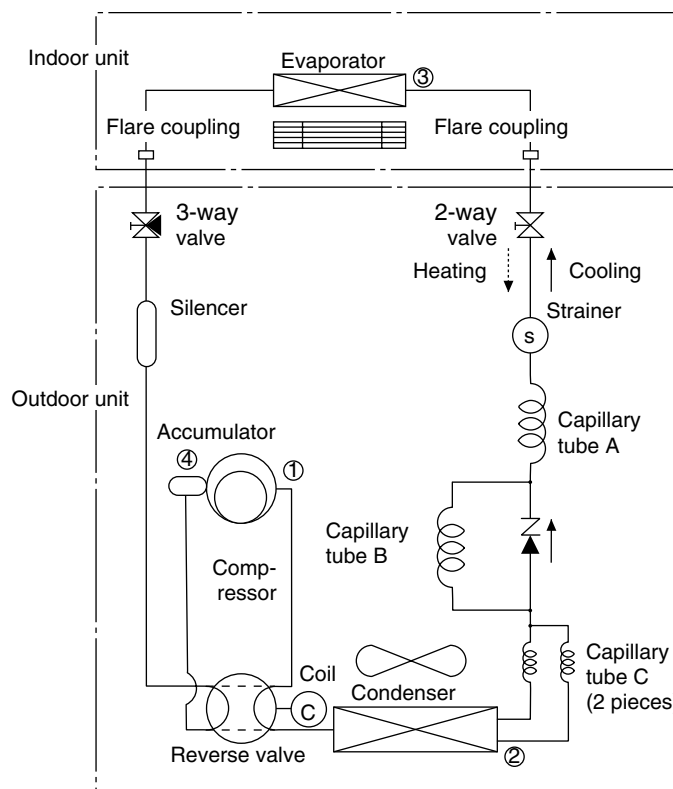

Figure R-1. Refrigeration Cycle for AY-XP08CE/10CE/13CE

Standard conditions:

AY-XP08CE / AY-XP10CE / AY-XP13CE

	Indoor side		Outdoor side	
	Dry-bulb Temp. (°C)	Relative Humidity (%)	Dry-bulb Temp. (°C)	Relative Humidity (%)
Cooling	27	47	35	40
Heating	20	—	7	87

Temperature at each part and pressure in 3-way valve

Model	AY-XP08CE				AY-XP10CE				AY-XP13CE			
	Cool (Max.)	Heat (Max.)	Cool	Heat	Cool (Max.)	Heat (Max.)	Cool	Heat	Cool (Max.)	Heat (Max.)	Cool	Heat
No. / Hz	80	more than 84	50 settle	50 settle	75	more than 83	50 settle	50 settle	98	more than 107	50 settle	50 settle
①	93°C	90°C	67°C	56°C	102°C	94°C	70°C	75°C	96°C	100°C	73°C	58°C
②	43°C	1°C	41°C	2°C	43°C	0°C	42°C	3°C	42°C	2°C	41°C	3°C
③	12°C	31°C	15°C	29°C	14°C	30°C	15°C	29°C	13°C	35°C	15°C	31°C
④	19°C	3°C	12°C	2°C	16°C	9°C	11°C	8°C	13°C	3°C	11°C	3°C
3-way valve pressure (MPaG)	0.50	1.70	0.60	1.28	0.47	1.66	0.62	1.30	0.45	1.80	0.64	1.20

Dimension of Capillary tube

Model	AY-XP08CE			AY-XP10CE			AY-XP13CE		
	O.D	I.D	L	O.D	I.D	L	O.D	I.D	L
Capillary tube A	ø2.7	ø1.4	500	ø2.7	ø1.5	600	ø2.7	ø1.6	300
Capillary tube B	ø2.7	ø1.4	400	ø2.7	ø1.5	400	ø2.7	ø1.6	300
Capillary tube C	ø2.7	ø1.6	150	ø2.7	ø1.6	150	ø2.7	ø1.6	150

PERFORMANCE CURVES

- NOTE: 1) Indoor fan speed: Hi
 2) Vertical adjustment louver "45°", Horizontal adjustment louver "front"
 3) Indoor air temp. : Cooling 27°C, Heating 20°C

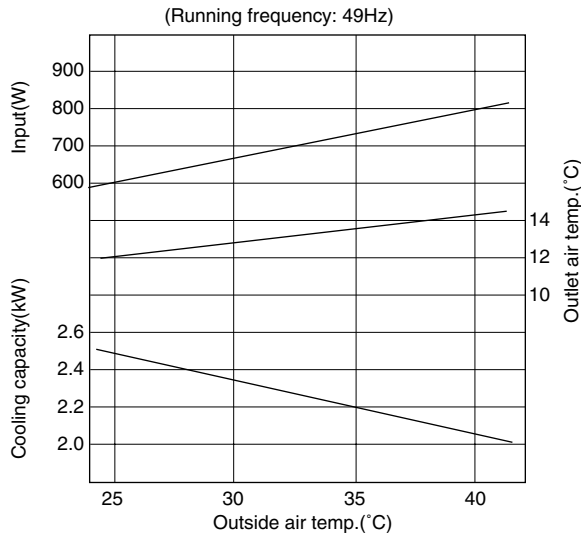

Figure P-1. At Cooling for AY-XP08CE

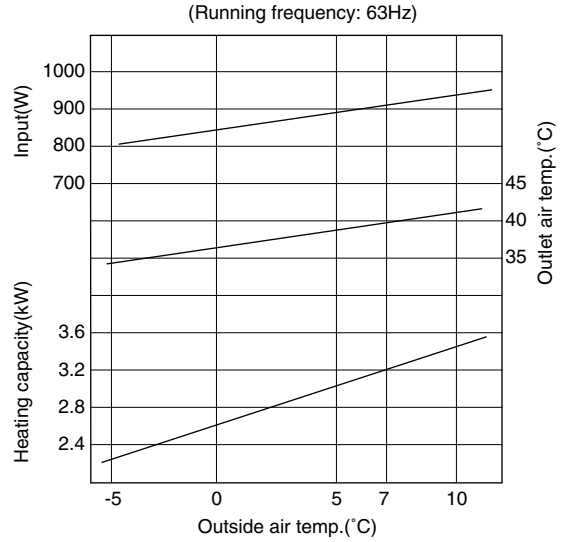

Figure P-4. At Heating for AY-XP08CE

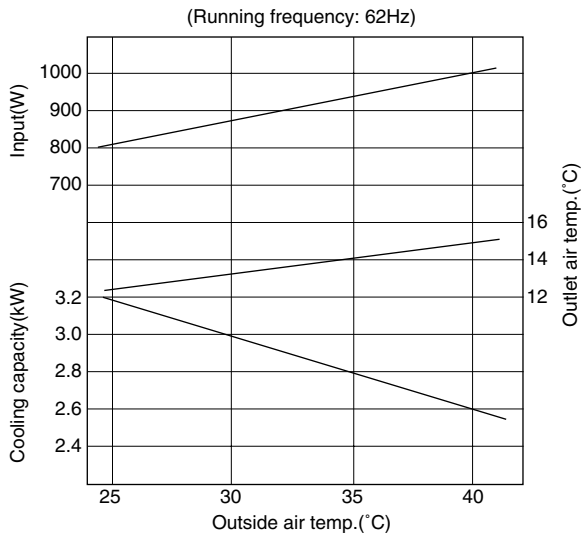

Figure P-2. At Cooling for AY-XP10CE

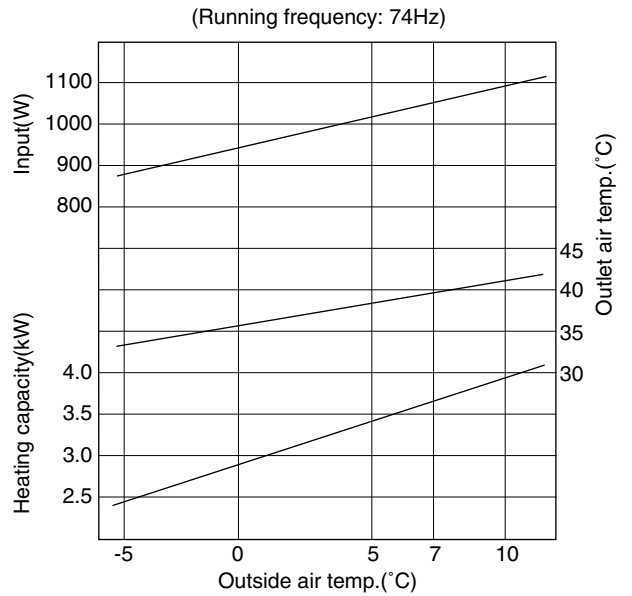

Figure P-5. At Heating for AY-XP10CE

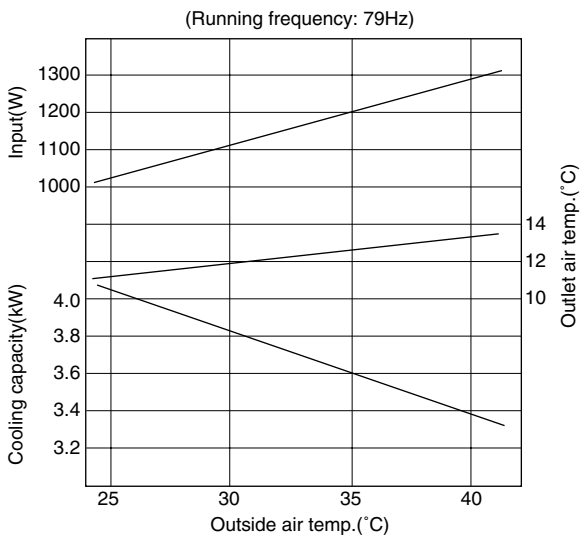

Figure P-3. At Cooling for AY-XP13CE

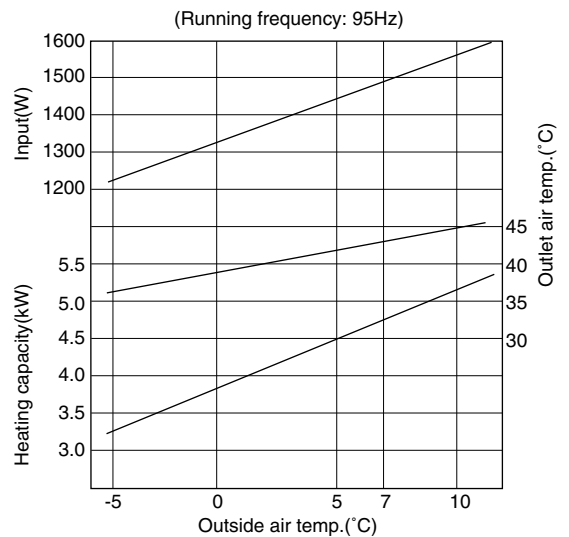
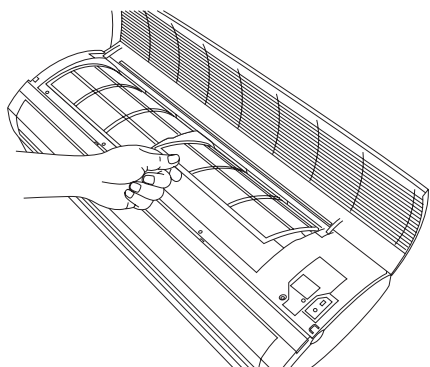

Figure P-6. At Heating for AY-XP13CE

DISASSEMBLING PROCEDURE

FOR INDOOR UNIT [AY-XP08CE/AY-XP10CE/AY-XP13CE]

CAUTION : DISCONNECT THE UNIT FROM THE POWER SUPPLY BEFORE ANY SERVICING



1. Open the open panel, and remove 2 air filters.

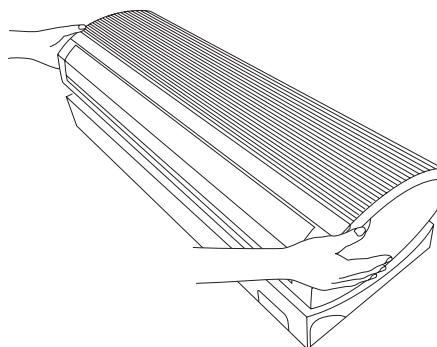

5. Pull the front panel up.

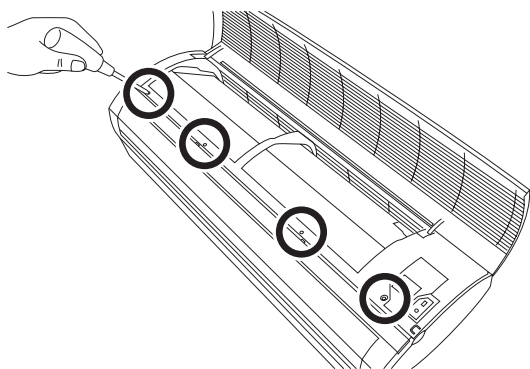

2. Remove 4 screws fixing the front panel.

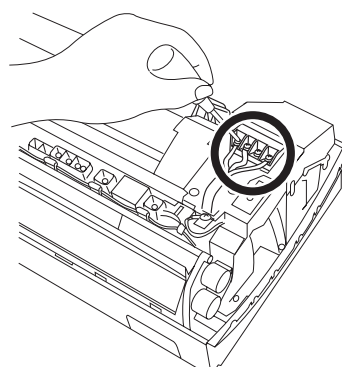

6. Remove the unit-to-unit wiring from the terminal board.

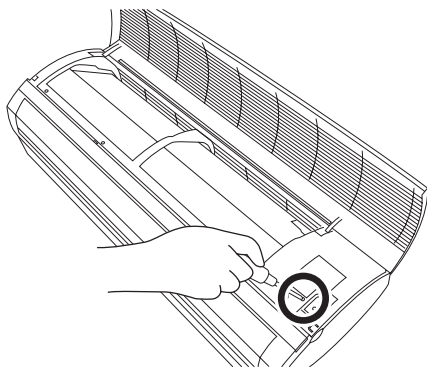

3. Remove the screw fixing the cord clamp.

Note :
During reassembly, install the holder after installing the front panel. This will make it easier to assemble the front panel.

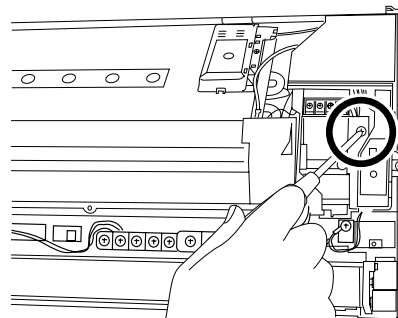

7. Remove a screw fixing the control box cover, and remove it.

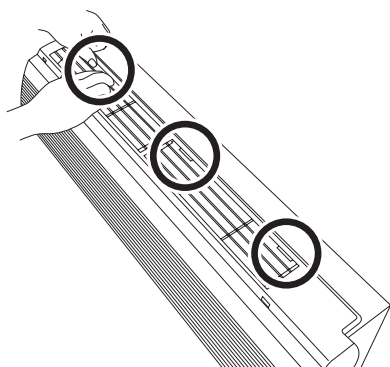

4. Close the open panel. Pushing the nail of the front panel.

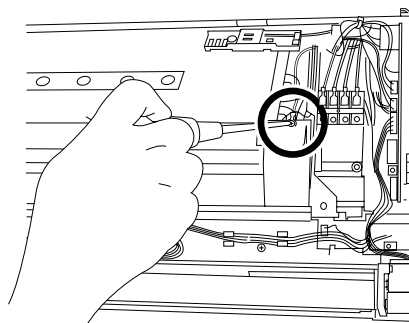

8. Remove 2 screws fixing the 2 ground wires and terminal.

Note :
During reassembly, take care direction of the lead wires.

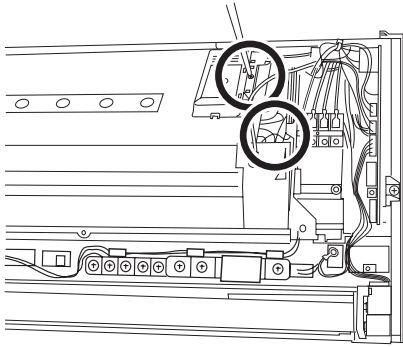

9. Remove 2 screws fixing the sensor holder, lead cover A and lead cover B from the evaporator.

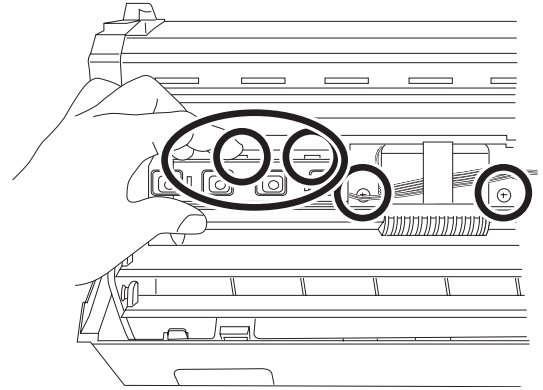

13. Pushing the 2 hooks of the holder, remove the display board unit 3 from the holder. And remove 2 screws fixing the cluster holder from the drain pan.

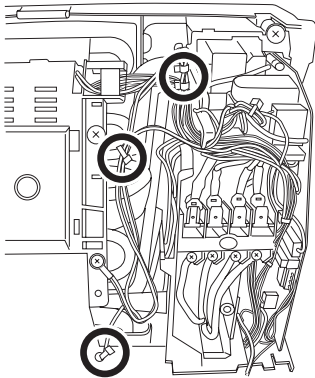

10. Cut off 3 fixing bands. During reassembly, fix them by fixing bands as same certainly.

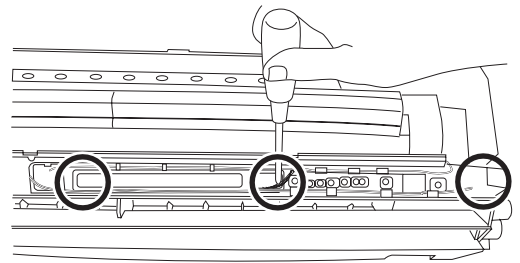

14. Remove 3 screws fixing the LED HOLDER B

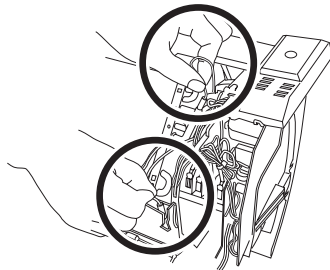

11. Remove 2 thermistors of the evaporator and the pipe.

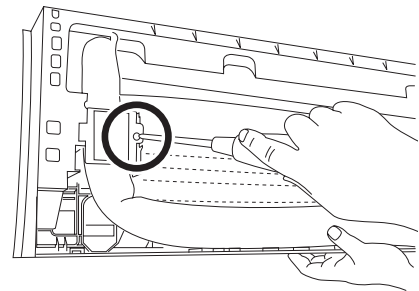

15. Remove the screw fixing the pipe holder.

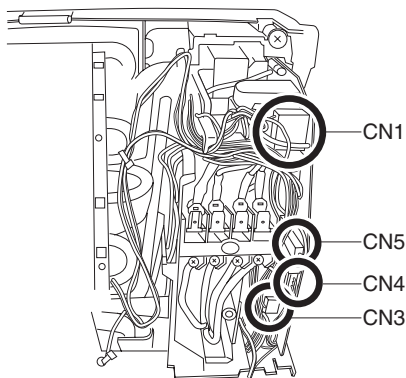

12. Remove 4 connectors.

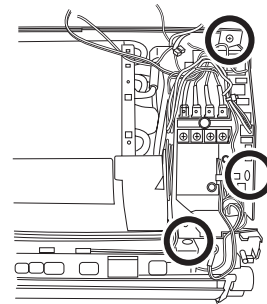

16. Remove 3 screws fixing the control box, and remove the control box.

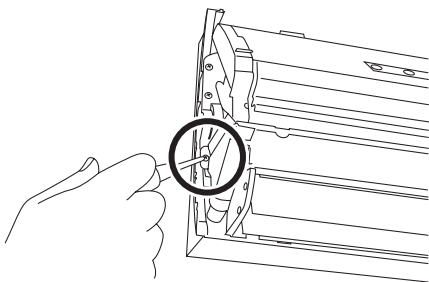

17. Remove a screw fixing the drain pan.

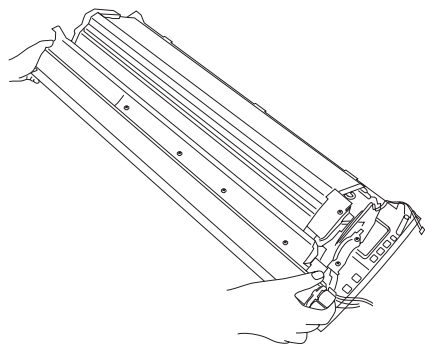

18. Pull the drain pan toward you.

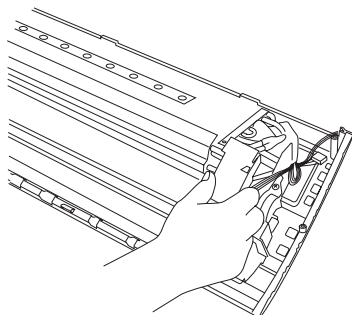

19. Remove the drain cover from the evaporator.

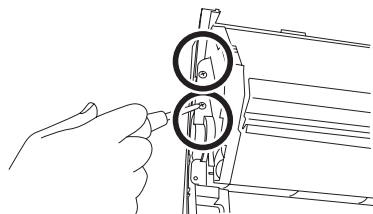

Note: During reassembly, verify that the dew on the pipe is led to the drain pan.

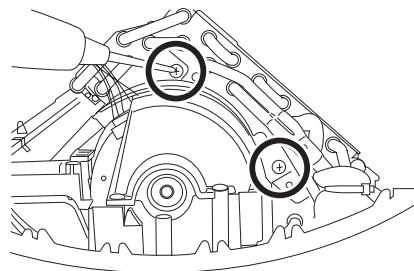

20. Remove 4 screws fixing the evaporator.

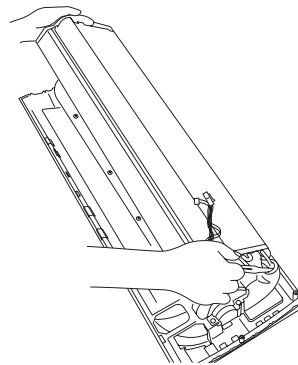

21. Remove the evaporator from the cabinet.

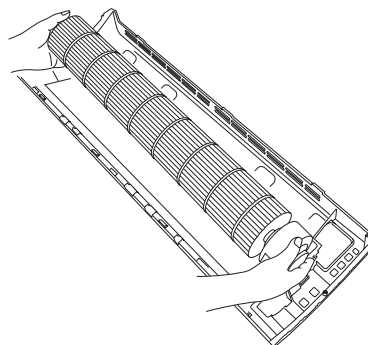
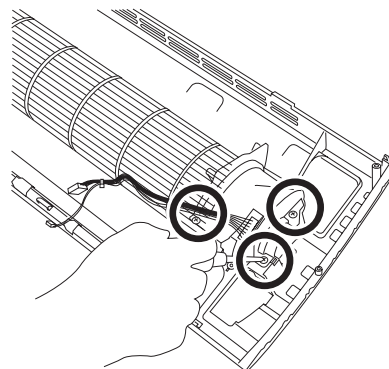

22. Remove 3 screws fixing the motor cover, and pull up the fan.

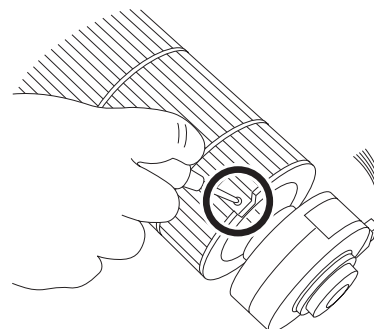

23. Loose a screw fixing fan.

[Cautionary points for assembling the fan]

- a. When inserting the motor shaft into the metal fan boss, take care to prevent injuring the inner surface of the metal fan boss.
- b. Before fastening the motor shaft and fan, insert the motor shaft into the metal fan boss until it stops.

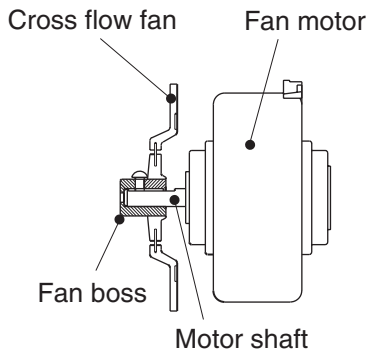

How to remove the display cover

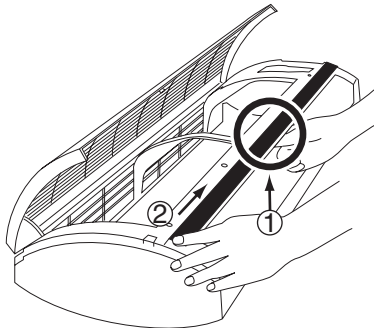

1. Push the center of display cover from the back.
2. Slide the display cover to the right.

How to assemble the display cover

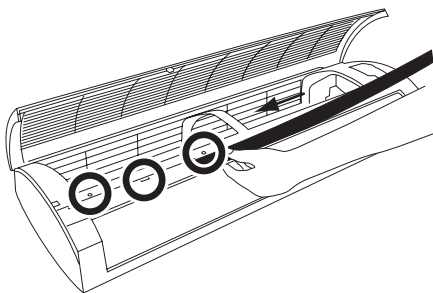

1. Slide the left end of the display cover through 2 hooks on the front panel along the guide from the center of the front panel.

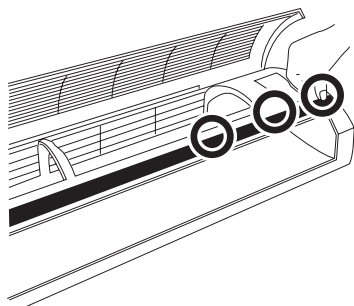

2. After the left half is inseted completely, press the display cover and snap in the 2 or 3 hooks on the right.

How to remove the control board

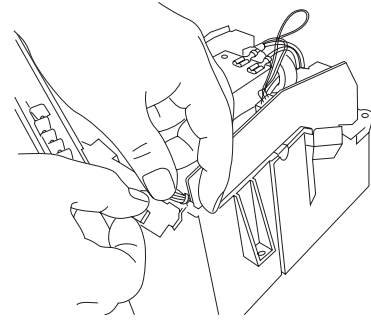

1. Remove the photo detector unit.
(Press and spread the upper hook, and the photo detector unit will be ready for removal.)

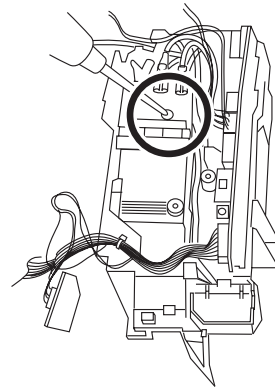

2. Remove the screw fixing the terminal board.

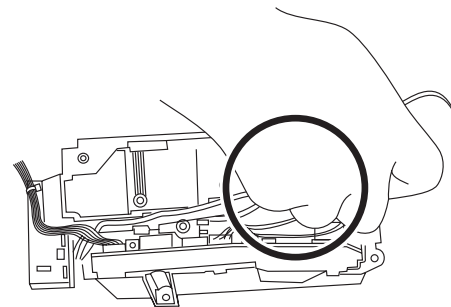

3. Remove 2 screws fixing the board (transformer).

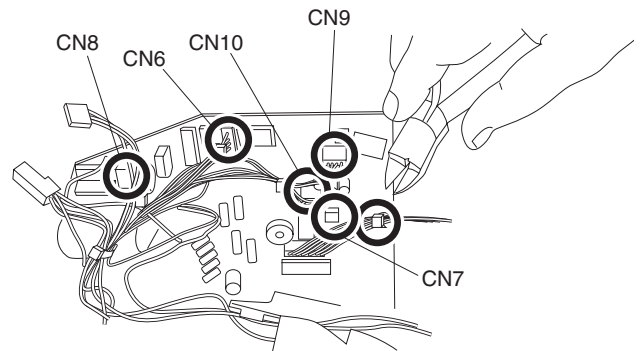

4. Remove 5 connectors. And cut off a fixing band.

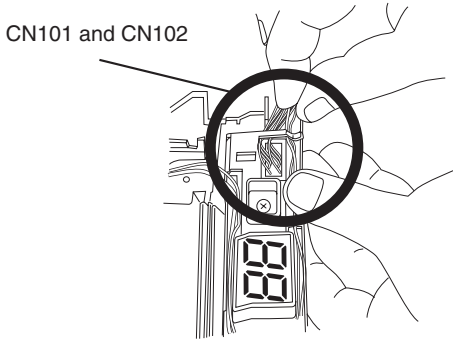

5. Remove 2 connectors.

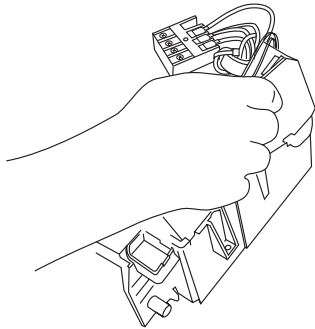

6. Pull the board.

Drain pan and related

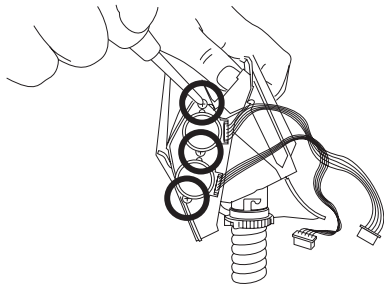

1. Remove 3 screws fixing motors.

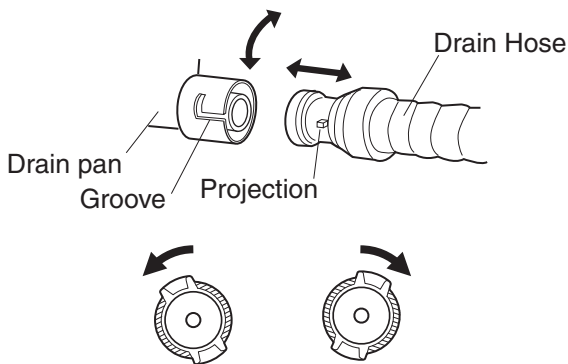

To disconned To reconnect

2. Turn the cap area of the drain hose counterclockwise, and remove it from the drain pan. During installation, turn the drain hose to the state of the “engagement position”. After reinstallation, verify that it is securely fastened.

How to remove the horizontal louver

Slightly pull down the hinge area, deflect the louver, and unhook it from the hinge. Remove the shaft from each of the left and right sides.

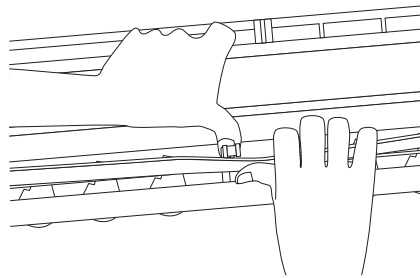

How to remove the HI VOLTAGE UNIT.

1. Remove the HIGH VOLTAGE UNIT.

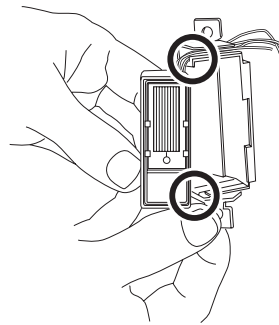

(Press and spread the hook, and HI VOLTAGE will be ready for removal.)

How to remove the DUST SENSOR, the THERMISTOR and the GAS SENSOR.

Remove the DUST SENSOR, the THERMISTOR, and the GAS SENSOR.

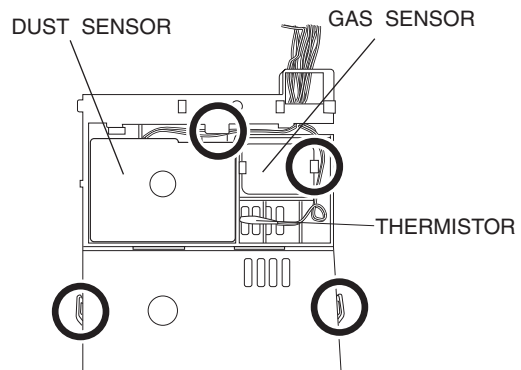

(Press and spread the hook, and GAS SENSOR will be ready for removal)

How to remove the display board unit 2.

The display board unit 2 is pushed in the direction of arrow ①. And it is made to slide in the direction of arrow ②, and remove.

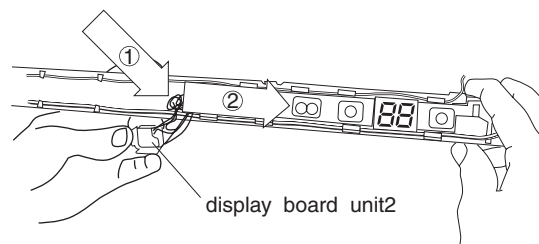

FOR OUTDOOR UNIT [AE-X08BE-C/X010BE-C/X13BE]

CAUTION : DISCONNECT THE UNIT FROM THE POWER SUPPLY BEFORE ANY SERVICING

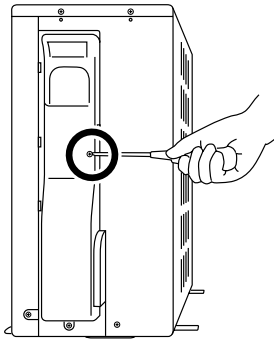

1. Loose a screw fixing the side cover.

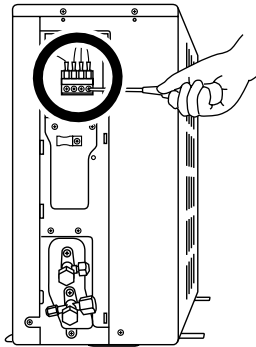
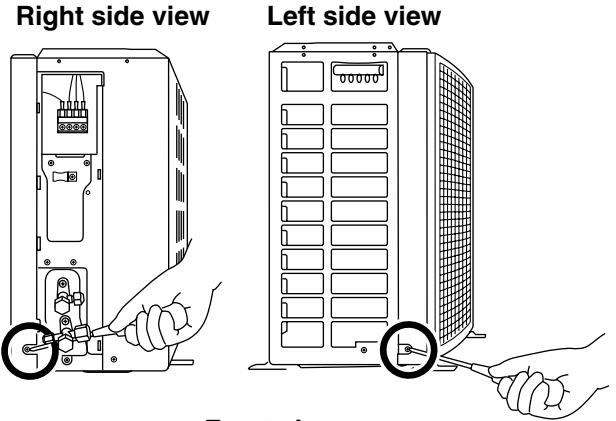

2. Loose the unit to unit cord.

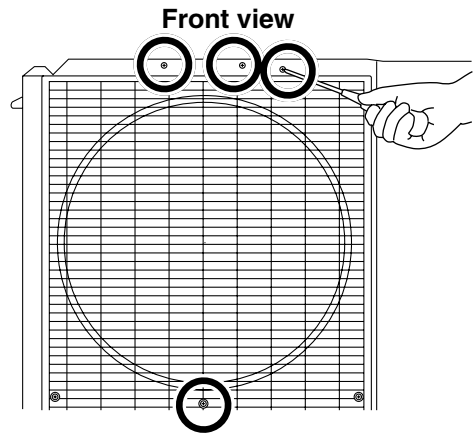

5. Loose 6 screws fixing the front panel.

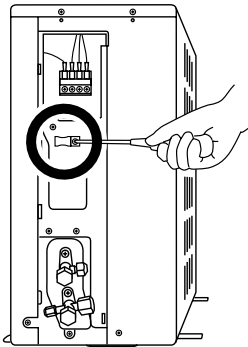

3. Loose a screw fixing the cord clamp.

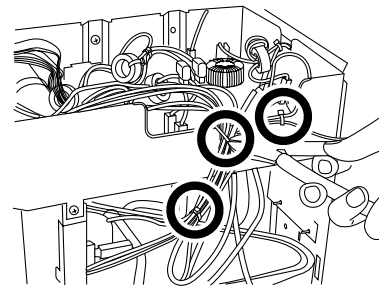

6. Cut 3 nylon bands.

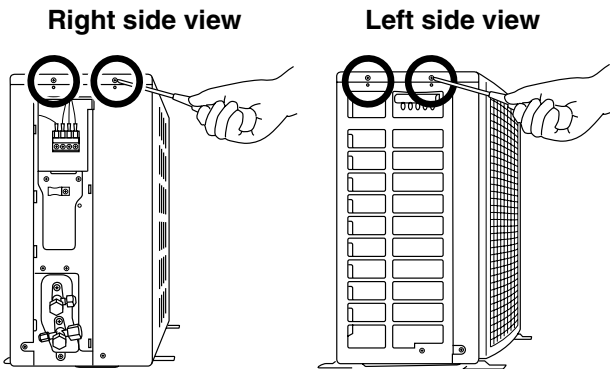

4. Loose 4 screws fixing the top panel.

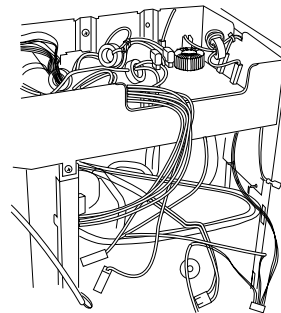

7. Disconnect following connectors and each wire.

- Choke coil(two terminal)
- Fan motor
- Thermistor
- Reverse valve (AE-X08BE-C/10BE-C/13BE)

DISASSEMBLING PROCEDURE OF THE FAN

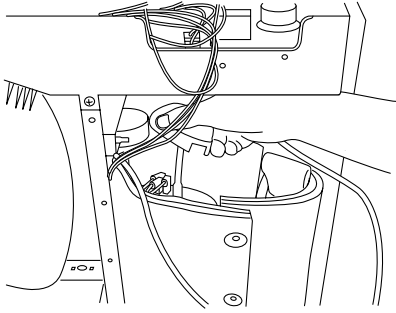

8. Remove the terminal cover of compressor.

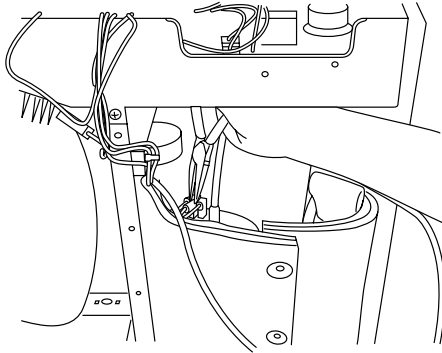

9. Remove 3 terminals of compressor..

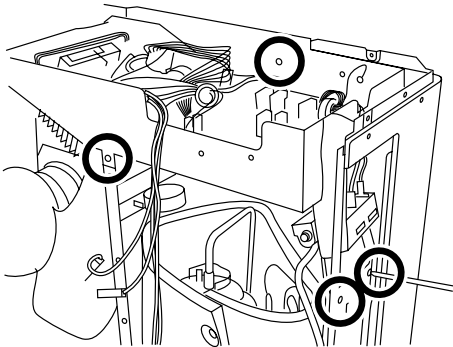

10. Loose 4 screws fixing the control box.

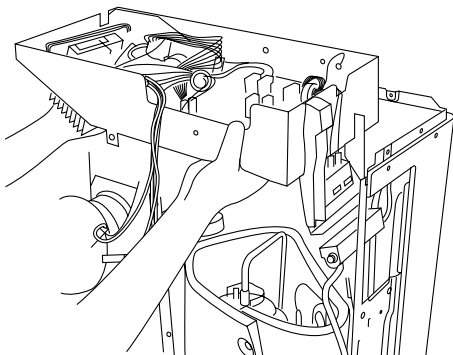

11. Take out the control box.

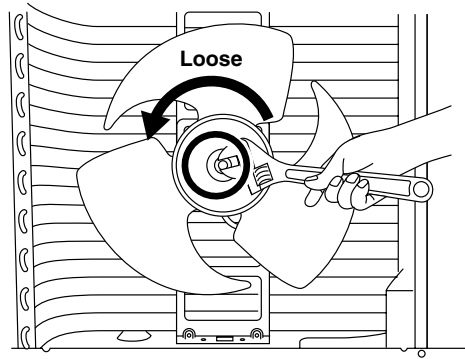

1. Loose the fan nut and fan can take out.

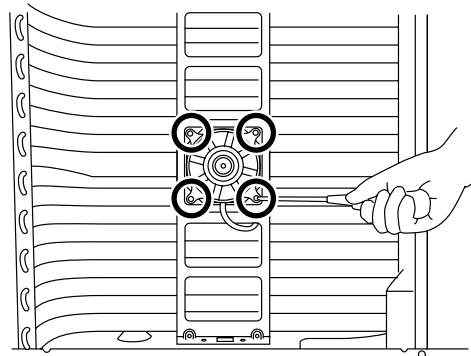

2. Fan motor is secured by 4 screws.

OPTION

HOW TO REPLACE THE DUST COLLECTION FILTER AND DEODORANT FILTER

(only for models AY-XPM7CR/AY-XPM9CR/AY-XPM12CR)

Precautions

The dust collection filter and the deodorant filter are packed as accessory of this unit. During operation of the air conditioner, the filters remove dust and tobacco smoke from the air and discharges clean air.

- The filters are sealed in a plastic bag to keep their dust collection effect. Do not open the bag until using the filters. (Otherwise the filters life may get shorter.)
- Do not expose the filters to direct sunlight. (Otherwise they may deteriorate.)

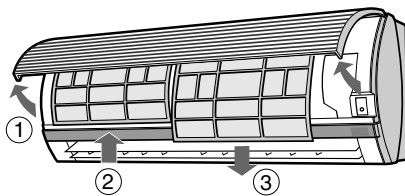

- 1 Take out the air filters.
 - ① Open the open panel.
 - ② Push the air filters up slightly to unlock them.
 - ③ Pull the air filters down to remove them.

DUST COLLECTION FILTER (gray)
 Set the black side facing upward.

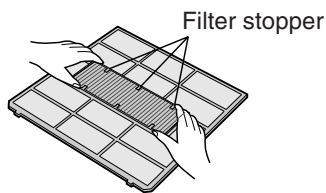

DEODORANT FILTER (green)

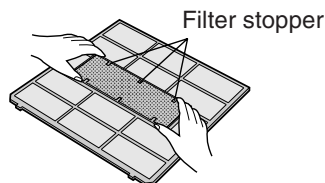

- 2 Check the filters.
 - ① Take of the old dust collection filter and the deodorant filter from the air filter. Snap out in the arrow marked direction.
 - ② Set the new dust collection filter and the deodorant filter with filter stopers located on the air filters.

- 3 Reinstall the air filters
 - ① Reinstall the air filters in the original positions.
 - ② Close the open panel.
 - ③ Push the arrow-marked of the panel firmly to lock it in place.

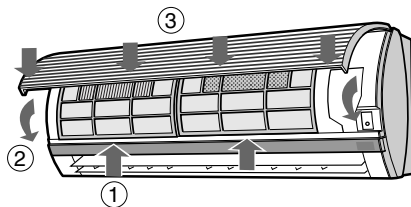

CLEANING THE DEODORANT FILTER (GREEN)

The filter should be cleaned every 3~6 months

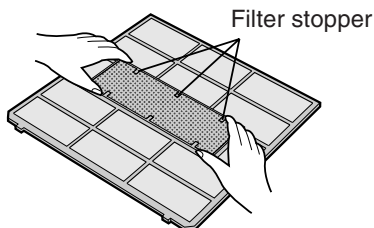
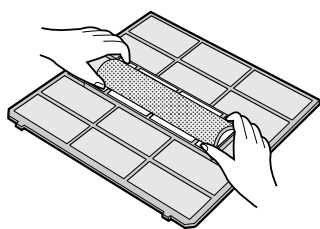

- 1 REMOVE THE AIR FILTERS**
- 2 CLEAN THE DEODORANT FILTER**
 - 1** Take off the deodorant filter from the air filters.
 - 2** Soak the deodorant filter in mild detergent dilution for 10 to 20 minutes.
Rinse thoroughly with water, dry completely under sunlight.
 - 3** Set the clean deodorant filter under the filter stoppers located on the air filters.
- 3 REINSTALL THE AIR FILTERS**

NOTE:

- Replacement is necessary at the interval of 3 years, as the deodorising effect will deteriorate.
The new filters are available at your nearest dealer.

Replacement filter: Type AZ-F910C

CHANGING THE DUST COLLECTION FILTER (GRAY)

The filter should be changed every 3~6 months

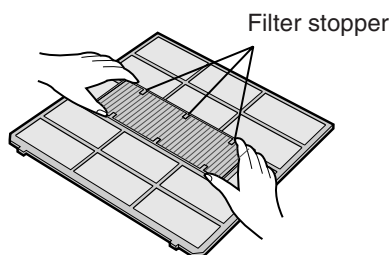

- 1 REMOVE THE AIR FILTERS**
- 2 CHANGE THE DUST COLLECTION FILTER**
 - 1** Take off the old dust collection filter from the air filters.
 - 2** Set the new dust collection filter, the black side facing upward, under the filter stoppers located on the air filters.
- 3 REINSTALL THE AIR FILTERS**

NOTE:

- The dirty dust collection filter is not washable for reuse.
The new filters are available at your nearest dealer.

Replacement filter: Type AZ-F900C

REPLACEMENT PARTS LIST [AY-XP08CE/XP10CE/XP13CE]

REF. NO.	PART NO.	DESCRIPTION	Q'TY	CODE
CABINET AND UNIT PARTS				
1- 1	CMOT-A397JBKZ	Fan motor sub ass'y	1	BG
1- 2	PGUMSA046JBE0	Damper rubber	1	AD
1- 3	CHLD-A067JBK0	Bearing ass'y	1	AL
1- 4	DCHS-A399JBKZ	Cabinet sub ass'y [AY-XP08CE]	1	BD
1- 4	DCHS-A401JBKZ	Cabinet sub ass'y [AY-XP10CE/XP13CE]	1	BC
1- 5	NFANCA089JBEZ	Cross flow fan	1	BD
1- 6	DSRA-A246JBKZ	Drain pan sub ass'y	1	BE
1- 7	CMOTLA915JBEZ	Fan motor	1	BK
1- 8	MJNTPA082JBFA	Louver link	2	AC
1- 9	MLOV-A299JBFA	Vertical louver	12	AC
1-10	MLOV-A334JBRA	Horizontal louver A	1	AM
1-11	MLOV-A298JBFA	Horizontal louver B	1	AK
1-12	QW-VZE022JBZZ	Lead wire (for Fan motor)	1	AM
1-13	LHLD-A197JBFP	Louver holder	2	AX
1-14	NBRG-A026JBFA	Louver bushing	2	AB
1-15	LHLD-A561JBFA	Holder	1	AM
1-16	PHOS-A025JBE0	Drain hose	1	AL
1-17	PPACGA010JBE0	O ring	1	AB
1-18	PGID-A097JBFZ	Drain cover	2	AF
1-19	RMOT-A061JBE0	Louver motor	2	AS
1-20	PGUMMA110JBE0	Drain plug	1	AD
1-21	CWAK-C213JBKZ	Front panel ass'y	1	BE
1-22	PPLT-A212JBFZ	Side cover R	1	AL
1-23	PPLT-A213JBFZ	Side cover L	1	AL
1-24	PCOV-A764JBRA	Display cover	1	BB
1-25	PFILMA145JBEA	Air filter	2	AL
1-26	DHLD-A010JBKZ	Tube holder ass'y	1	AK
1-27	HPNL-A514JBTA	Open panel	1	AQ
1-28	TSPC-E067JBRA	Name label [AY-XP08CE]	1	AC
1-28	TSPC-E066JBRA	Name label [AY-XP10CE]	1	AC
1-28	TSPC-E065JBRA	Name label [AY-XP13CE]	1	AC
1-29	PFPPFB901JBEZ	Cabinet insulator [AY-XP08CE]	1	AH
1-30	QW-VZE013JBZZ	Lead wire (for Louver motor:Upper)	1	AG
1-31	GWAK-A271JBFA	Front panel	1	AV
1-32	PCOV-A614JBFZ	Drain cover	1	AG
1-33	TLABCB584JBRZ	Wiring diagram	1	AC
1-34	QW-VZD893JBZZ	Lead wire (for Louver motor:Lower)	1	AG
1-35	LHLD-A303JBFA	Tube cover	1	AD
1-36	PSEL-C125JBEZ	Panel insulator	1	AF
1-37	PFPPFB971JBEZ	Sheet	1	AA
1-38	PSPA-A154JBEZ	Rubber spacer	1	AD
1-39	PSHE-A126JBE0	Evaporator seal	1	AG
1-40	LSPR-A007JBE0	Sheet spring	2	AD
1-41	LHLD-A536JBFA	Holder	1	AM
1-42	PFPPFB962JBEZ	Sidecover insulator	1	AC
1-43	PFPPFB967JBEZ	Insulator	1	AC
1-44	HDEC-B147JBEA	Display panel	1	AQ
1-45	PSEL-C055JBEZ	Evaporator seal	1	AC
1-46	PSEL-C136JBEZ	Insulator [AY-XP10CE/XP13CE]	1	AC
1-47	PSEL-C294JBEZ	Aluminum tape	1	AC
1-48	TLAB-C211JBRZ	Filter label	1	AE
1-49	DCOV-A206JBKZ	Cover ass'y	1	AE
1-50	PCOV-A821JBEZ	Lead cover A	1	AC
1-51	PCOV-A822JBEZ	Lead cover B	1	AC

CONTROL BOX

2- 1	RTHM-A300JBE0	Thermistor	1	AP
2- 2	PBOX-A342JBFZ	Control box	1	AQ
2- 3	PBOX-A341JBFZ	Terminal cover	1	AH
2- 4	VSKRA105M/-3	Transistor (Q1, Q2, Q10)	3	AB
2- 5	VS2SA1585SQR3	Transistor (Q8)	1	AD
2- 6	HPNLCA776JBFA	Control box cover	1	AG
2- 7	HPNLCA777JBEA	Control panel	1	AD
2- 8	PCOV-A618JBFB	Led holder	1	AE
2- 9	PCOV-A766JBFA	Led holder B	1	AE
2-10	DPWBFA265JBKZ	Control board unit [AY-XP08CE]	1	BS
2-10	DPWBFA266JBKZ	Control board unit [AY-XP10CE]	1	BS
2-10	DPWBFA264JBKZ	Control board unit [AY-XP13CE]	1	BS
2-11	QACC-A158JBE0	Power supply cord	2	AT
2-12	QTANZA002JBEZ	Terminal board (3PIN)	1	AN
2-13	QTANZA001JBZZ	Terminal board (4PIN)	1	AQ
2-14	PCOV-A609JBWZ	Control box cover	1	AC
2-15	RIC--A025BDE0	IC (IC4, IC5)	2	AE

REF. NO.	PART NO.	DESCRIPTION	Q'TY	CODE
2-16	VHPGL6ZS27+-6	LED (LED102)	1	AG
2-17	VHPSL326422-6	LED (LED121)	1	AP
2-18	PCOV-A611JBWZ	Control box cover	1	AF
2-19	PCOV-A610JBWZ	Terminal cover	1	AE
2-20	RRMCUA001JBZZ	Photo detector unit (IC201)	1	AK
2-21	QFS-GA040JBZZ	Fuse 3A 250V (WPE1)	1	AE
2-22	VHIKID65783-1	IC (IC6)	1	AK
2-23	RIC--A022BDE0	IC (IC3)	1	AE
2-24	VHIBR24C01A-6	IC (IC8)	1	AF
2-25	RH-TZA098JBEO	Transistor (Q3 - Q7, Q9)	6	AB
2-26	RC-HZA329JBEO	Fan motor capacitor (C1)	1	AP
2-27	RH-VXA002JBZZ	Varistor (NR1)	1	AF
2-28	RH-IZA149JBEO	IC (IC2)	1	AE
2-29	VHPGL6ZE27+-6	LED (LED103 - LED111)	9	AG
2-30	RTRN-A287JBZZ	Transformer (TR1)	1	AT
2-31	VHPGL6ZR27+-6	LED (LED101)	1	AF
2-32	VHRPC817X7/1B	Photo coupler (PC1)	1	AD
2-33	VHRPC853H/-6	Photo coupler (PC2)	1	AG
2-34	VHRS201D01/-6	Solid state relay (SSR1)	1	AK
2-35	VHD1SR139-6-1	Diode (D6, D8, D9)	3	AB
2-36	VHD1SR35-4A-1	Diode (D1- D5)	5	AC
2-37	VHEHZ24-2//1	Zener diode (ZD1)	1	AB
2-38	RH-IZA140JBEO	IC (IC7)	1	AE
2-39	RDTA-A001KKE0	Gas sensor (GS1)	1	AW
2-40	VHRPR33MF11-6	Solid state relay (SSR2)	1	AX
2-41	VHPGL5BG502-1	LED (LED131)	1	AR
2-42	RSNSZA001JBZZ	Dust sensor	1	BD
2-43	PFPFPB970JBEZ	Sheet	1	AA
2-44	LHLD-A540JBFA	Holder	1	AM
2-45	LHLD-A550JBFA	Display cover	1	BE
2-46	LHLD-A560JBFA	Sensor holder	1	AM
2-47	LHLD-A562JBFA	Holder	1	AM
2-48	RH-IXA705JBZZ	Micro computer (IC1)	1	AV
2-49	CKITTA002JBKZ	Hi voltage unit ass'y	1	BA

CYCLE PARTS

3- 1	CPIPCA678JBKZ	Tube ass'y (AY-XP08CE)	1	BG
3- 1	CPIPCA690JBKZ	Tube ass'y (AY-XP10CE)	1	BH
3- 1	CPIPCA679JBKZ	Tube ass'y (AY-XP13CE)	1	BH
3- 2	PSEN-A005JBKZ	Flare nut ass'y (1/4")	1	AG
3- 3	PSEN-A004JBKZ	Flare nut ass'y (3/8") (AY-XP08CE/XP10CE)	1	AE
3- 3	PSEN-A016JBKZ	Flare nut ass'y (1/2") (AY-XP13CE)	1	AR
3- 4	PVLV-0341JBEO	Flare Union (1/4")	1	AG
3- 5	PVLV-0342JBEO	Flare Union (3/8") (AY-XP08CE/XP10CE)	1	AH
3- 5	PVLV-0406JBEO	Flare Union (1/2") (AY-XP13CE)	1	AK
3- 6	DEVA-A121JBKZ	Evaporator sub ass'y (AY-XP08CE)	1	BS
3- 6	DEVA-A128JBKZ	Evaporator sub ass'y (AY-XP10CE)	1	BT
3- 6	DEVA-A122JBKZ	Evaporator sub ass'y (AY-XP13CE)	1	BT

ACCESSORY PARTS

4- 1	CRMC-A569JBEZ	Remote control	1	BD
4- 2	UBATUA027JBEO	Battery pack	1	AE
4- 3	LHLD-A477JBFA	Cord holder (for covering the terminal board of indoor unit)	1	AE
4- 4	XTTSD40P16000	Tapping Screw (for fixing the cord holder)	1	AA
4- 5	LX-NZA207JBEZ	Special nut (for fixing long screw steadily)	9	AE
4- 6	PPLTNA058JBWZ	Mounting angle	1	AS
4- 7	XTTSD45P30000	Long screw	8	AA
4- 8	LX-BZA106JBEO	Special screw (for hanging remote controller)	1	AE
4- 9	LPFT-A029JBF0	Drain joint	1	AD
4-10	GLEGGA008JBEO	Compressor cushion	4	AE
4-11	TINSEA298JBRZ	Operation manual	1	AR
4-12	TINS-A710JBRZ	Installation manual	1	AG
4-13	TINS-A711JBRZ	Installation manual	1	AG

SCREW

5- 1	LX-BZA075JBEO	Special screw (for earth)	1	AA
------	---------------	---------------------------	---	----

PACKING PARTS

6- 1	CPADBA038JBKZ	Packing Pad Ass'y	2	AK
6- 2	SPAKA990JBEZ	Packing case [AY-XP08CE]	1	AQ
6- 2	SPAKA989JBEZ	Packing case [AY-XP10CE]	1	AQ
6- 2	SPAKA988JBEZ	Packing case [AY-XP13CE]	1	AQ

INDOOR UNIT FOR AY-XP08CE/XP10CE/XP13CE

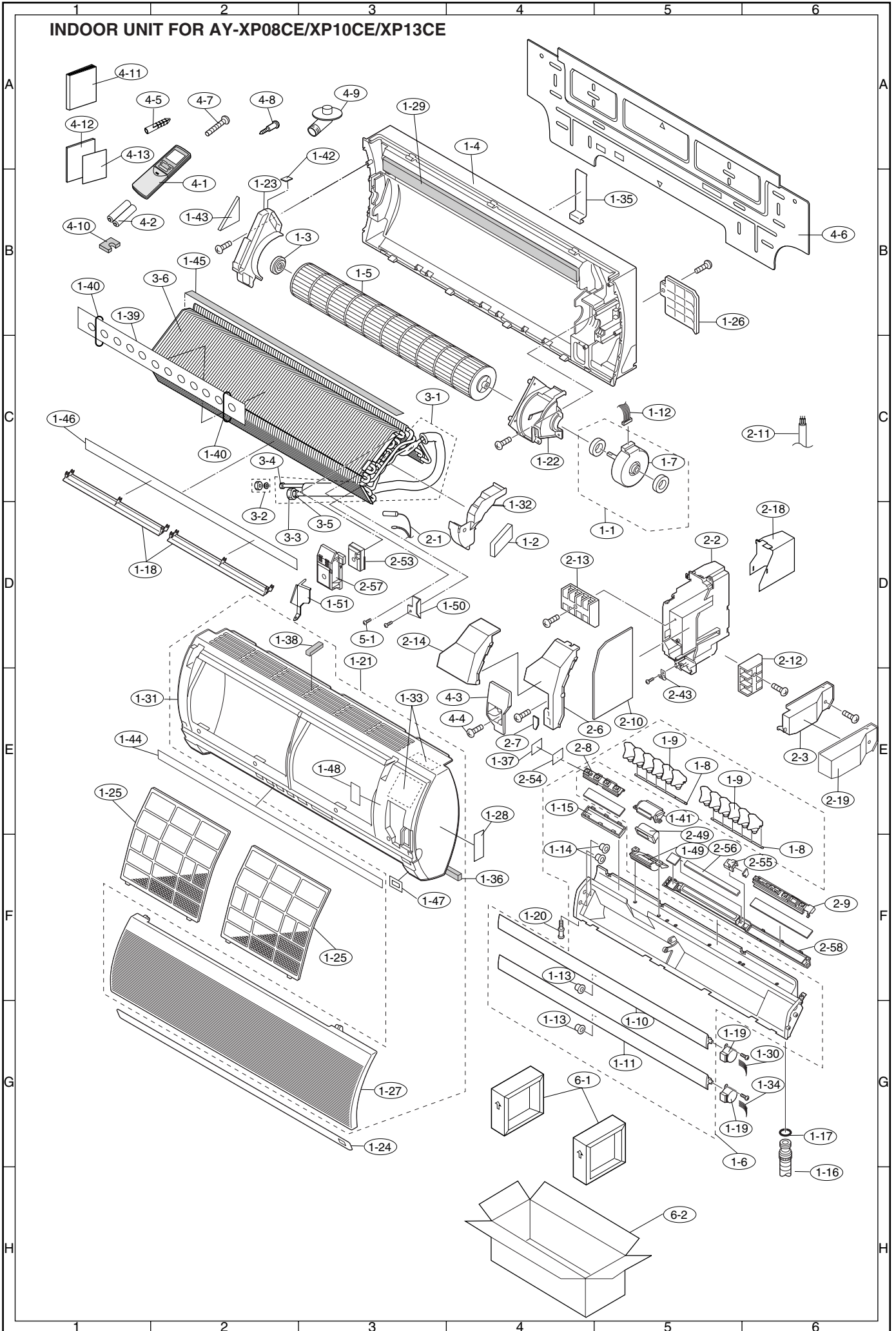

REPLACEMENT PARTS LIST [AE-X08BE-C/10BE-C/13BE]

REF. NO.	PART NO.	DESCRIPTION	Q'TY	CODE
CONTROL BOX PARTS				
1- 1	CMOTLA902JBEZ	Fan motor [AE-X08BE-C/X10BE-C]	1	BK
1- 1	CMOTLA903JBEZ	Fan motor [AE-X13BE]	1	BL
1- 2	RTRN-A256JBE0	Current transfoemer CT1	1	AG
1- 3a	RFIL-A104JBZZ	Common coil [AE-X08BE-C/X10BE-C]	1	AR
1- 3b	RFIL-A105JBZZ	Common coil [AE-X08BE-C/X10BE-C/X13BE]	1	AR
1- 3c	RFIL-A106JBZZ	Common coil [AE-X13BE]	1	AV
1- 4	DPWBFA282JBKZ	Electric control board [AE-X08BE-C/X10BE-C]	1	BP
1- 4	DPWBFA240JBKZ	Electric control board [AE-X13BE]	1	BQ
1- 5	QTANZA001JBZZ	Terminal board (4P)	1	AQ
1- 6	RIC-A022BDE0	Integrated circuit IC2 [AE-X08BE-C/X10BE-C]	1	AE
1- 6	VHIK7818API-1	Integrated circuit IC2 [AE-X13BE]	1	AF
1- 7	VSKRC245M// -3	Transistor Q3	1	AC
1- 8	VHRPC817X7/1B	Photo coupler PC1	1	AE
1- 8	VHRPC817X7/1B	Photo coupler PC1,PC3, PC4 [AE-X13BE]	3	AE
1- 9	VHRPC853H// -6	Photo coupler PC2	1	AG
1-10	RC-AZA046JBE0	Capacitor [AE-X08BE-C/X10BE-C]	1	BE
1-10	RC-EZA249JBZZ	Capacitor [AE-X13BE]	1	BP
1-11	RH-DZA117JBE0	Diode bridge [AE-X08BE-C/X10BE-C]	1	AM
1-11	RH-DZA087JBE0	Diode bridge [AE-X13BE]	1	AQ
1-12	RH-HZ0011JBE0	PTC thermistor	1	AN
1-13	RH-TZA145JBE0	Power transistor module (IPM) [AE-X08BE-C/10BE-C]	1	BU
1-13	VHITM38++++-1	Power transistor module (IPM) [AE-X13BE]	1	BY
1-14	PDAI-A126JBWZ	Terminal plate	1	AE
1-15	VHITM-05C// -6	Active filter [AE-X08BE-C/X10BE-C]	1	BP
1-15	RH-TXA003JBZZ	Active filter [AE-X13BE]	1	BS
1-16	RTHM-A022JBE0	Compressor thermistor	1	AN
1-17	RH-HXA010JBZZ	Thermistor	1	AX
1-18	RTRN-A199JBE0	Choke coil [AE-X08BE-C/X10BE-C]	1	BE
1-18	RTRN-A286JBEZ	Choke coil [AE-X13BE]	1	BF
1-19	PBOX-A343JBWZ	Control box	1	AR
1-20	LBND-A042JBE0	Wire fixing band	10	AC
1-21	PSPA-A151JBZZ	Spacer	5	AE
1-22	LHLD-A479JBFZ	Heat sink holder	1	AE
1-23	PRDAFA140JBEZ	Heat sink for powertransistor module [AE-X08BE-C/10BE-C]	1	AX
1-23	PRDAFA142JBEZ	Heat sink for powertransistor module [AE-X13BE]	1	AX
1-24	QW-VZD962JBZZ	Lead wire (CN14-QM1) [AE-X13BE]	1	AE
1-25	PSHE-A190JBEZ	Protect sheet	1	AL
1-26	PSEL-C061JBEZ	Insulator	1	AE
1-27	PSPA-A144JBE0	Spacer	2	AC
1-28	RFIL-A064JBE0	Ferrite core	5	AF
1-29	QW-VZD961JBZZ	Lead wire (CN13-AF1) [AE-X13BE]	1	AG
1-30	QW-VZD871JBZZ	Lead wire (L1+, L1-)	2	AG
1-31	QW-VZD857JBZZ	Lead wire (Earth)	1	AC
1-32	QW-VZD868JBZZ	Lead wire (MRY1 - DB1)	1	AG
1-33	QW-VZD861JBZZ	Lead wire (MRY1 - PTC)	1	AF
1-34	QW-VZD958JBZZ	Lead wire (DB1+-AF(I+))	1	AK
1-35	QW-VZD866JBZZ	Lead wire (T3 - TB2)	1	AF
1-36	QW-VZD873JBZZ	Lead wire (T10 - IPM(-))	1	AF
1-37	QW-VZD867JBZZ	Lead wire (T5 - DB1))	1	AG
1-38	QW-VZD864JBZZ	Lead wire (T2 - TBN)	1	AF
1-39	QW-VZD865JBZZ	Lead wire (T1 - TB1)	1	AF
1-40	QW-VZD859JBZZ	Lead wire (C8(+) - T7)	1	AE
1-41	QW-VZD870JBZZ	Lead wire (C8(+)- AF(0+)) [AE-X08BE-C/X10BE-C]	1	AG
1-42	QW-VZD960JBZZ	Lead wire (C8-AF) [AE-X13BE]	1	AL
1-43	QW-VZD869JBZZ	Lead wire (C8(-) - AF(0-)) [AE-X08BE-C/X10BE-C]	1	AF
1-44	QW-VZD860JBZZ	Lead wire (C8(-) - T8)	1	AE
1-45	QW-VZD872JBZZ	Lead wire (T9 - IPM(+))	1	AE
1-46	QW-IZA023JBZZ	Lead wire (Compressor wire) [AE-X08BE-C]	1	AS
1-46	QW-IZA022JBZZ	Lead wire (Compressor wire) [AE-X10BE-C]	1	AM
1-46	QW-IZA019JBZZ	Lead wire (Compressor wire) [AE-X13BE]	1	AP
1-47	QW-VZD420JBE0	Lead wire (AF lead wire 4P)	1	AE
1-48	RH-IXA726JBZZ	Microcomputer IC1	1	AW
1-49	RH-IZA140JBE0	Integrated circuit IC3	1	AE
1-50	RH-TZA098JBE0	Transistor Q1, Q2	2	AB
1-51	RH-VZA020JBE0	Varistor CNR1, CNR2	2	AB
1-52	RH-VXA002JBZZ	Varistor NR1, NR2	2	AD
1-53	RH-VZA042JBE0	Surge absorber SA1	1	AH
1-54	LBNDKA099JBWZ	Capacitor clamp	1	AS
1-55	PSEL-C122JBEZ	Insulator	1	AC
1-56	PSEL-C123JBEZ	Insulator	1	AC
1-57	PSEL-C124JBEZ	Insulator	1	AC

REF. NO.	PART NO.	DESCRIPTION	Q'TY	CODE
CABINET AND UNIT PARTS				
2- 1	LANGKA124JBPZ	Fan motor angle	1	AR
2- 2	LANGKA127JBPZ	Fan motor angle sub [AE-X08BE-C/X10BE-C]	1	AE
2- 2	LANGKA123JBPZ	Fan motor angle sub [AE-X13BE]	1	AE
2- 3	GCAB-A196JBTA	Rear cabinet	1	BD
2- 4	LHLD-A573JBFA	Cord clamp	1	AC
2- 5	PPFFPB911JBEZ	Motor angle cushion	1	AC
2- 6	GCAB-A195JBTA	Front panel	1	BC
2- 7	GGADFA037JBFA	Fan guard	1	AT
2- 8	PSEL-C045JBEZ	Motor angle cushion	1	AB
2- 9	PSEL-C048JBEZ	F panel insulator	1	AC
2-10	PSEL-C049JBEZ	F panel insulator	1	AC
2-11	PSEL-C050JBEZ	Bulkhead insulator	1	AG
2-12	TLABBA148JBRA	Sharp badge	1	AH
2-13	CCHS-A779JBTA	Base pan assembly [AE-X08BE-C]	1	BD
2-13	CCHS-A770JBTA	Base pan assembly [AE-X10BE-C]	1	BC
2-13	CCHS-A735JBTA	Base pan assembly [AE-X13BE]	1	BD
2-14	PFTA-A092JBFA	Side cover	1	AQ
2-15	PCOV-A616JBPZ	Protect cover	1	AE
2-16	MSPR-A027JBE0	Thermistor spring [AE-X08BE-C/X10BE-C]	1	AB
2-16	MSPR-A026JBE0	Thermistor spring [AE-X13BE]	1	AB
2-17	MSPR-A046JBE0	Protector spring [AE-X10BE-C/X13BE]	1	AC
2-17	MSPR-A104JBE0	Protector spring [AE-X08BE-C]	1	AQ
2-18	NFANPA094JBEZ	Propeller fan	1	AX
2-19	PSKR-A223JBWZ	Bulkhead [AE-X08BE-C/X10BE-C]	1	AR
2-19	PSKR-A211JBWZ	Bulkhead [AE-X13BE]	1	AQ
2-20	TLABKD002JBRZ	Number card [AE-X08BE-C]	1	AC
2-20	TLABKD003JBRZ	Number card [AE-X10BE-C]	1	AC
2-20	TLABKC747JBRZ	Number card [AE-X13BE]	1	AH
2-21	TSPC-E038JBRZ	Name badge [AE-X08BE-C]	1	AD
2-21	TSPC-E039JBRZ	Name badge [AE-X10BE-C]	1	AD
2-21	TSPC-D593JBRZ	Name badge [AE-X13BE]	1	AE
2-22	PSEL-C051JBEZ	Side cover seal	1	AE
2-23	FFTA-A014JBKZ	Side cover assembly	1	AT
2-24	TLABCB543JBRZ	Wiring diagram [AE-X08BE-C]	1	AE
2-24	TLABCB537JBRZ	Wiring diagram [AE-X10BE-C]	1	AE
2-24	TLABCB430JBRZ	Wiring diagram [AE-X13BE]	1	AE
2-25	DCAB-A114JBKZ	Top cover assembly [AE-X08BE-C]	1	AY
2-25	DCAB-A110JBKZ	Top cover assembly [AE-X10BE-C]	1	AY
2-25	DCAB-A104JBKZ	Top cover assembly [AE-X13BE]	1	AZ
2-26	PSEL-C060JBEZ	Insulator for rear cabinet	1	AB
2-27	GCAB-A197JBTA	Top cover	1	AX
2-28	JHNDPA011JBFA	Holder	1	AS
2-29	PSEL-C046JBEZ	Bulkhead insulator	1	AC
2-30	PSEL-C119JBEZ	Box insulator	1	AE
2-31	PSEL-C047JBEZ	Box insulator	1	AF
2-32	PSEL-C062JBEZ	Box insulator	1	AG
2-33	CHLD-A093JBK0	Holder assembly	1	AL
2-34	PSEL-C121JBEZ	Side cover seal	1	AC
2-35	PSEL-C120JBEZ	Side cover seal	1	AC
2-36	LPLTPA026JBFA	Cord clamp plate	1	AC

CYCLE PARTS

3- 1	CVLV-A621JBKZ	Reverse valve assembly [AE-X08BE-C]	1	BP
3- 1	CVLV-A620JBKZ	Reverse valve assembly [AE-X10BE-C]	1	BN
3- 1	CVLV-A574JBKZ	Reverse valve assembly [AE-X13BE]	1	BW
3- 2	DCPY-A218JBKZ	Capillary tube assembly [AE-X08BE-C]	1	BF
3- 2	DCPY-A212JBKZ	Capillary tube assembly [AE-X10BE-C]	1	BF
3- 2	DCPY-A217JBKZ	Capillary tube assembly [AE-X13BE]	1	BF
3- 3	PCON-A455JBPZ	Condensor [AE-X08BE-C/X10BE-C]	1	BT
3- 3	PCON-A445JBPZ	Condensor [AE-X13BE]	1	BS
3- 4	DVLV-A520JBKZ	3 way valve unit [AE-X08BE-C/X10BE-C]	1	AW
3- 4	DVLV-A466JBKZ	3 way valve unit [AE-X13BE]	1	BA
3- 5	LX-NZA037JBE0	Service nut [AE-X13BE only]	1	AG
3- 6	LX-BZA268JBEZ	Special screw [AE-X08BE-C, AE-X10BE-C]	1	AB
3- 6	LX-BZA060JBE0	Special screw [AE-X13BE]	1	AH
3- 7	DVLV-A521JBKZ	2 way valve unit [AE-X08BE-C/X10BE-C]	1	AT
3- 7	DVLV-A462JBKZ	2 way valve unit [AE-X13BE]	1	AW
3- 8	FCMPRA110JBKZ	Compressor ass'y (Including for Ref.No.3-9,3-11,3-12,2-17) [AE-X08BE-C]	1	CE
3- 8	FCMPRA120JBKZ	Compressor ass'y (Including for Ref.No.3-9,3-10,3-11) [AE-X10BE-C]	1	CE
3- 8	FCMPRA065JBK0	Compressor ass'y (Including for Ref.No.3-9,3-10,3-11) [AE-X13BE]	1	CM
3- 9	PCMPRA338JBEZ	Compressor [AE-X08BE-C]	1	CA
3- 9	PCMPRA350JBEZ	Compressor [AE-X10BE-C]	1	CB
3- 9	PCMPRA267JBE0	Compressor [AE-X13BE]	1	CK
3-10	LBSHCA005JBE0	Terminal bushing [AE-X10BE-C/X13BE]	1	AA
3-11	PCOV-0562JBE0	Terminal cover [AE-X10BE-C/X13BE]	1	AD
3-11	PCOV-A321JBE0	Terminal cover [AE-X08BE-C]	1	AR
3-12	PSEL-A971JBE0	Terminal gasket [AE-X08BE-C]	1	AN

REF. NO.	PART NO.	DESCRIPTION	Q'TY	CODE
3-14	LX-NZA136JBEO	Special nut [AE-X08BE-C]	1	AL
3-15	GLEG-A076JBEO	Compressor cushion [AE-X08BE-C]	3	AK
3-15	GLEG-A029JBEO	Compressor cushion [AE-X10BE-C/X13BE]	3	AE
3-16	PSPF-A767JBEZ	Compressor cover [AE-X08BE-C/X13BE]	1	AV
3-16	PSPF-A828JBEZ	Compressor cover [AE-X10BE-C]	1	AQ
3-17	PSPF-A830JBEZ	Compressor cover [AE-X08BE-C]	1	AE
3-17	PSPF-A829JBEZ	Compressor cover [AE-X10BE-C]	1	AF
3-17	PSPF-A768JBEZ	Compressor cover [AE-X13BE]	1	AG
3-18	PSEN-A004JBKO	Flare nut ass'y	1	AE
3-19	PSEN-A005JBKO	Flare nut ass'y [AE-X08BE-C/X10BE-C]	1	AG
3-19	PSEN-A016JBKO	Flare nut ass'y [AE-X13BE]	1	AR
3-20	PGUM-A135JBEZ	Compressor sheet	1	AG
3-21	PSPF-A797JBE0	Compressor cover	1	AG
3-22	PMUF-A026JBEO	Muffler [AE-X08BE-C/X10BE-C]	1	AL
3-22	PMUF-A054JBEZ	Muffler [AE-X13BE]	1	AT
3-23	PVLVXA044JBEZ	Reverse valve [AE-X08BE-C/X10BE-C]	1	BG
3-23	PVLVXA039JBE0	Reverse valve [AE-X13BE]	1	BD
3-24	LX-NZA037JBEO	Bonnet [AE-X13BE only]	1	AG
3-25	CCIL-A112JBEZ	Coil [AE-X08BE-C, AE-X10BE-C]	1	AX
3-25	CCIL-A097JBEZ	Coil [AE-X13BE]	1	AV

SCREWS AND NUTS

4- 1	LX-BZA140JBEO	Special screw	32	AB
4- 2	LX-BZA072JBEO	Special screw (for 2/3 way valve unit)	4	AB
4- 3	XTTSD40P14000	Tapping screw	1	AA
4- 4	LX-BZA166JBEO	Special screw	3	AB
4- 5	LX-NZA026JBEO	Special nut (for compressor)	3	AC
4- 6	LX-BZA075JBEO	Special screw	2	AA
4- 7	LX-BZA140JBEO	Special screw	7	AB
4- 8	LX-BZA075JBEO	Special screw (for Earth)	1	AA
4- 9	XBPSD40P20JS0	Machine screw (for IPM)	5	AB
4-10	LX-NZA135JBEO	Special nut (for propeller fan)	1	AC
4-11	XBPSD40P20J00	Machine screw (for DB1)	1	AA
4-12	XCTSD40P12000	Tapping screw (for Terminal board ass'y angle, for capacitor clamp)	2	AA
4-13	XTPSD30P12XS0	Tapping screw 3mm x 16mm (for PWB assembly)	2	AC
4-14	LX-BZA292JBEZ	Tapping screw 3mm x 16mm (for Top cover)	8	AC
4-15	XTTSD40P16000	Tapping screw (for Heatsink)	1	AA
4-16	LX-BZA140JBEO	Special screw (for Heatsink holder)	1	AB
4-17	XCTSD40P16000	Tapping screw (for Terminal board ass'y)	1	AA

PACKING PARTS

6- 1	CPADBA031JBKZ	Bottom pad assembly	1	AS
6- 2	SPAKCA963JBEZ	Packing case [AE-X08BE-C]	1	AX
6- 2	SPAKCA964JBEZ	Packing case [AE-X10BE-C]	1	AX
6- 2	SPAKCA687JBEZ	Packing case [AE-X13BE]	1	AY
6- 3	CPADBA032JBKZ	Packing pad ass'y	1	AL

HOW TO ORDER REPLACEMENT PARTS

To have your order filled promptly and correctly, please furnish the following information.

- | | |
|-----------------|----------------|
| 1. MODEL NUMBER | 2. REF. NO. |
| 3. PART NO. | 4. DESCRIPTION |

OUTDOOR UNIT FOR AE-X08BE-C/X10BE-C/X13BE

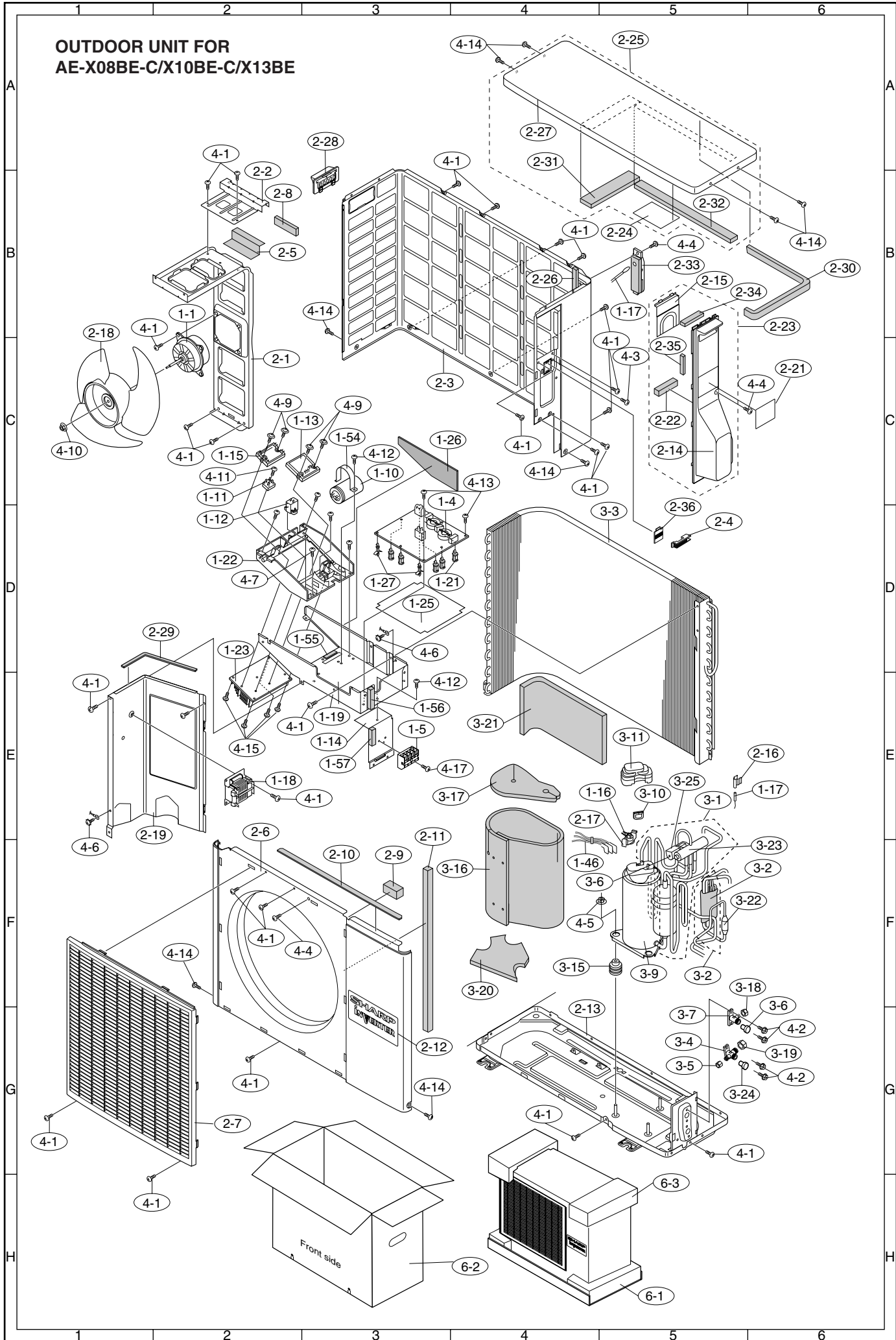

SHARP