

CHAPTER 3. FUNCTIONS

[1] FUNCTION

1. TEMPERATURE CONTROL CHARACTERISTIC

1.1. COOL operation

In the "COOL" mode, the thermostat circuit is controlled by four thermostat lines (C1 thru C5).

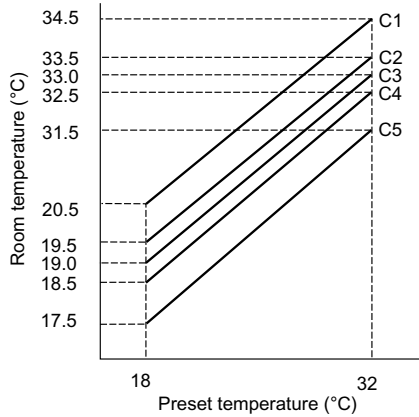

1.2. DRY operation

In the "DRY" mode, the thermostat circuit is controlled by three thermostat lines (D1 thru D3).

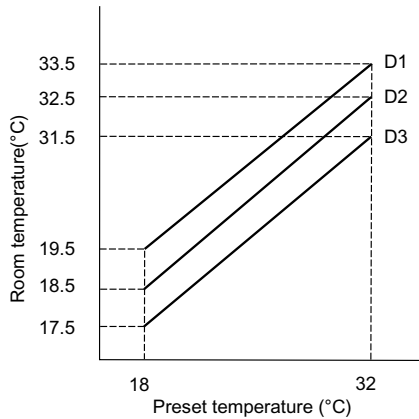

1.3. HEAT operation

In the "HEAT" mode, the thermostat circuit is controlled by six thermostat lines (H01 thru H4).

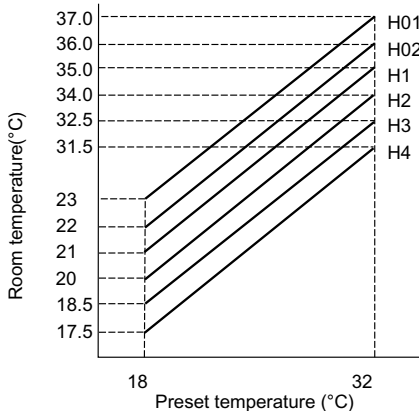

2. OPERATION MODES

2.1. COOL operation

The compressor turns on or off, at the thermostat lines C3 and C4. The outdoor fan motor is also controlled with the compressor.

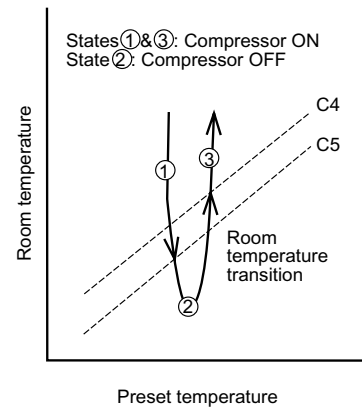

2.2. DRY operation

On the switch on, the compressor always starts to operate for 2 minutes with fan speed "DL".

The microcomputer reads the room temperature 2 minutes after this first compressor operation.

This room temperature is set as the preset temperature automatically. The preset temperature ranges from 18°C to 32°C. When the room temperature is below 18°C, the preset temperature is set to 18°C, and when the room temperature is over 32°C, the preset temperature is set to 32°C.

Dry operation is divided into three zones (Cooling zone, Dehumidifying zone and Circulating zone) by thermostat lines (D1 to D3), and the compressor and the fan motor are controlled in each zone as shown in Table.

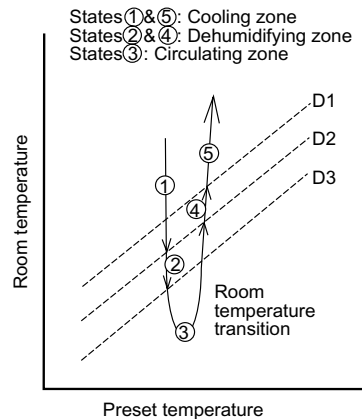

	Compressor	Fan speed
Cooling zone	ON	DH
Dehumidifying zone	ON	DL
Circulating zone	OFF	DL or OFF

2.3. Heat operation

The compressor turns on or off, at State 2, turns on continuously at State 1 & 3.

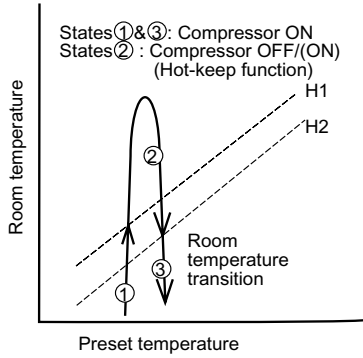

3. FAN SPEED

Fan speeds are given by the indoor fan motor, "DL"~"HH" which are available in the following operation mode.

Fan speed	Fan switch	Fan switch (AUTO)	AY-AP7FHR	AY-AP9FHR
DL	—	DRY	700	770
DH	—		790	820
CL	COOL SOFT	—	650	650
CAL	—	COOL	790	820
CM	COOL LOW		950	1010
CAH	—		1040	1100
CH	COOL HIGH	—	1055	1115
HUL	—	—	780	800
HL	HEAT SOFT	—	880	900
HAL	—	HEAT	880	900
HM	HEAT LOW		980	1050
HAH	—		1100	1130
HH	HEAT HIGH		1175	1205

(r.p.m.)

4. HOT-KEEP

This function automatically controls the on-off operation of the indoor fan motor in accordance with the ON-OFF operation of the compressor during the heating operation, thereby preventing the air conditioner from delivering a cold air when the compressor is off. When the room temperature enters area "D", the compressor is turned off, and the indoor fan motor is turned off after rotating at "HUL" for 30 seconds. 3 minutes after turning on the compressor, the compressor is turned on for 3 minutes. At 10 seconds after turning on the compressor, the indoor fan motor is turned on. The next compressor OFF time is accordance with the room temperature area when 3 minutes elapse after turning on the compressor. If the area "D", compressor OFF time is for 3 minutes and if "E", it's for 8 minutes. If the area "F", compressor is not turned on. Only the indoor fan motor is turned on 8 minutes later for 3 minutes.

Area "D": To becoming below line H2 after becoming above line H1
Area "E": To becoming below line H1 after becoming above line H02
Area "F": To becoming below line H02 after becoming above line H01

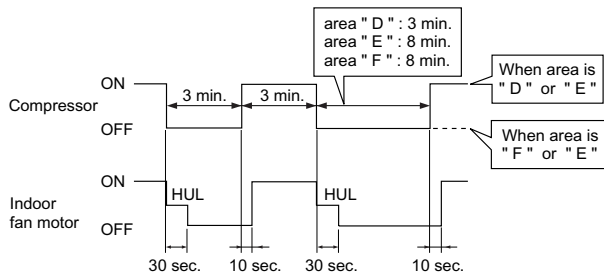

5. PREHEAT AIR FLOW

This function is intended to prevent cold air from being discharged when the heating operation starts or when defrosting. When the indoor pipe temperature is below 29°C at the beginning of the heat operation or after defrosting, the indoor fan motor stays.

When the indoor pipe temperature gets higher than 29°C, the fan motor is turned on at speed "HUL" after compensation of starting. When the indoor pipe temperature exceeds 35°C, the specified fan speed is restored. When the indoor pipe temperature falls below 30°C, the fan speed shifts down to "HUL". And, when the indoor pipe temperature falls below 23°C, the fan motor turns off. Then, over 29°C, it turns on again at speed "HUL".

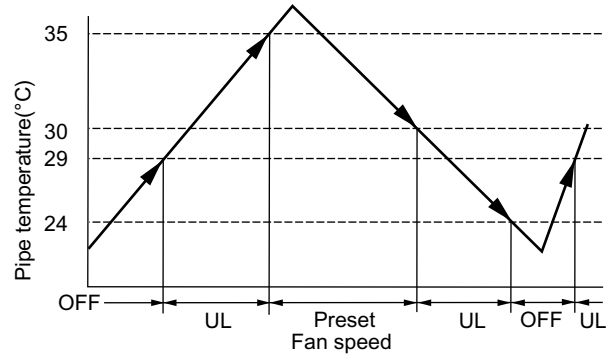

6. OVERHEATING PROTECTION SYSTEM

When overloading occurs during the heating operation, this system controls the outdoor fan motor according to the indoor pipe temperature to prevent the overloading of the compressor and restrain the rise in high pressure.

When the indoor pipe temperature exceeds U1digC, the outdoor fan motor is turned off, and when the indoor pipe temperature falls U2digC, the outdoor fan motor turns on.

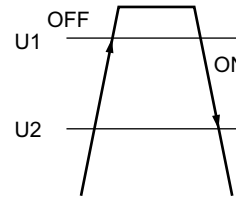

U1 and U2 are different by the time.

- ① within 3 minutes
- ② over 3 minutes

MODELS	Fan Lline	HH		HAH		HM	
		①	②	①	②	①	②
AY-AP7FHR	U1	53°C	53°C	53°C	53°C	54°C	54°C
	U2	49°C	52°C	49°C	52°C	50°C	53°C
AY-AP9FHR	U1	53°C	53°C	53°C	53°C	54°C	54°C
	U2	49°C	52°C	49°C	52°C	50°C	53°C

MODELS	Fan Lline	HAL		HL		HUL	
		①	②	①	②	①	②
AY-AP7FHR	U1	54°C	54°C	54°C	54°C	54°C	54°C
	U2	50°C	53°C	50°C	53°C	50°C	53°C
AY-AP9FHR	U1	54°C	54°C	54°C	54°C	54°C	54°C
	U2	50°C	53°C	50°C	53°C	50°C	53°C

7. CURRENT CONTROL

This system, in order to prevent overcurrent during heating operation, controls the outdoor fan motor and changes the indoor fan motor speed by detecting total current. When the current exceeds P2, the outdoor fan motor is automatically turned off, and when the current falls below P4, the outdoor fan motor is turned on.

When the current exceeds P3 and the indoor fan speed shifts down because of cold air (5. Preheat air flow), the changes in the indoor fan speed shifts up as follows, from "off" to "HUL", or from "HUL" to "HL". And when the current falls below P5, the indoor fan speed shift up is canceled.

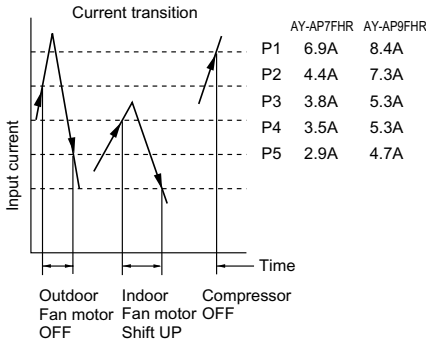

8. FREEZE PREVENTIVE

When the indoor pipe temperature falls below 0°C during cool operation or dry operation, the compressor is turned off.

9. DEFROST

The defrost timer (integrating the operation time of compressor) counts time with microcomputer during heat operation.

Frost of outdoor pipe is estimated by indoor pipe temperature (TH2), room temperature (TH1), indoor fan speed and operation state of compressor.

In the defrost operation, first the compressor is turned off, the fan speed is set to "HUL" and the outdoor fan motor is turned off.

30 seconds later the indoor fan motor is turned off, 60 seconds later the reverse valve is turned off, and the compressor is turned on. In the end of defrosting, the compressor is turned off, the outdoor fan motor is turned on, 60 seconds later the reverse valve is turned on, and the compressor is turned on, starting heat operation. At this time, the indoor fan motor is turned off or the fan speed is set to "HUL" if preheat air flow function is effective.

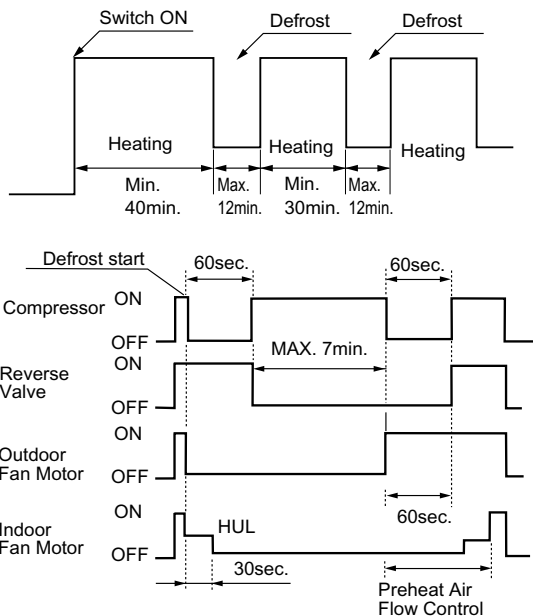

10. DELAYED OPERATION OF THE REVERSE VALVE

the heat operation is shut down or the operating mode is switched from heat to cool or dry, or vice versa, the reverse valve is switched after 3 minutes.

11. TEST RUN

If the "AUX" button on the unit is pressed for 5 seconds or more during operation, cool test operation starts. The operation LED (red) flickers during test run.

To put the system in the heating test run mode, start the cooling operation and select the heating mode on the remote control. In cool and heat mode continuous compressor on operation is performed. In dry mode the operation is in dehumidifying zone. In fan only mode the indoor fan motor runs continuously.

12. TIMER

12.1. ON/OFF TIMER

When the unit operates during one hour after the OFF-time is set, thermostat setting is automatically shifted (+1digC in cool operation and dry operation, -3digC in heat operation, 16digC - 32digC). When the ON-timer is set in heat operation and cool operation, operation starts before 0 to 30 minutes(depends on the room temperature) so that pre-set temperature is obtained at set time.

12.2. ONE-HOUR TIMER

When ONE-HOUR timer is set, the unit turns off automatically after one hour. The one hour timer operation has priority over other time operation, such as the TIMER ON and TIMER OFF. If the ONE-HOUR TIMER button is pressed again during operation, the unit will operate additionally for another one hour.

13. AUTOMATIC AIR CONDITIONING

Automatic air conditioning is selected, the operation mode and preset temperature are set automatically according to the room temperature on starting operation.

Room temperature at operation start	Operation Mode	Preset Temperature
Above 28°C	COOL	26°C
26°C ~ 28°C		25°C
24°C ~ 26°C		24°C
21°C ~ 24°C	DRY	Room temperature at operation start
Below 21°C	HEAT	23°C

When DRY mode is selected by the micro computer with AUTO operation, the fan speed lamps on the indoor unit panel will indicate identically with the fan speed symbols on the remote control display, as the FAN speed setting is changed accordingly. Despite, the actual fan speed will not change, as it is determined automatically by the micro computer.

14. AUTOMATIC FAN SPEED

When the automatic fan speed is selected in cool or heat operation, the fan speed is automatically changed by the thermostat lines C1 to C3 in cool operation, and H1 to H4 in heat operation.

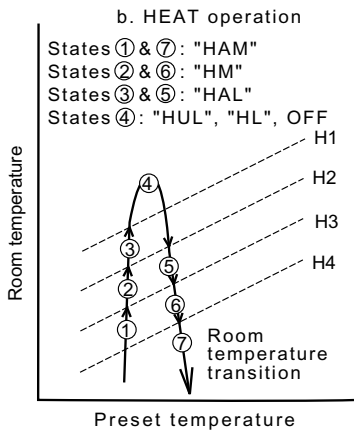
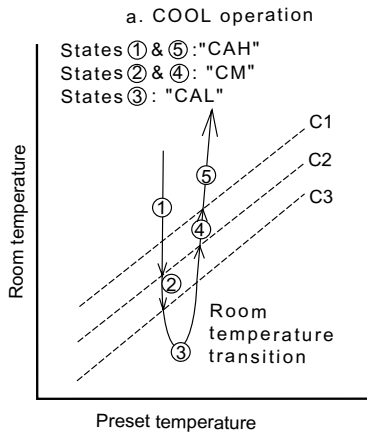

15. OUTPUTS IN EACH OPERATION MODE

Mode	Compressor	Outdoor Fan Motor	Indoor Fan Motor	Valve Coil	
COOL	Cooling	ON	ON	ON	OFF
	Circulating	OFF	OFF	ON	OFF
HEAT	Normal	ON	ON	ON	ON
		OFF	OFF	ON/UL/OFF	ON
	Preheat Air Flow Control	ON	ON	UL/OFF	ON
DRY	ON Defrost	ON	OFF	OFF	OFF
DRY	Cooling	ON	ON	L/UL	OFF
	Dehumidifying	ON	ON	UL/D	OFF
	Circulating	OFF	OFF	D/OFF	OFF

16. POWER ON START

If the connecting wire JP4 is cut on the PWB ass'y, when the power is supplied by turning on a circuit breaker, the air conditioner automatically starts of operation in "AUTO".

(Refer to Figure L-5. ~ L-8. Printed Wiring Board.)

17. AUTO RESTART

Power failure occurs during operation, the unit will restart in the same operation mode as before after power recovery.

18. PLASMA CLUSTER

Plasma cluster ion mode

SSR2 : ON

[2] TEST MODE

Keep pushing the "AUX." buttons and supply the power, the system will go to the test mode. In this mode, the output of operation is switched by pushing the "AUX." button in the unit or the "OI" button in the remote controller. Normal outputs are shown in Table.

1. AY-AP7FHR

STEPNo	Buzzer	LED				P. C Power	Outdoor Fan	4W-Valve	Compressor	Indoor Fan	Louver	
		Operation LED102 (RED)	Timer LED103 (YELLOW)	Turbo LED101 (GREEN)	P. C LED104 (BLUE)							
0	2times	Room temp	Heat-exchanger	○	○	x	x	x	x	OFF	OFF	
		7~42°C ○ Except above x	-2~45°C ○ Except above x									
1	1time	CT	Auto-restart	Model select		x	x	○	x	○	SETTING TEMP: AUTO 1225rpm HEATING TURBO 18°C 700rpm DRY LOW 19°C 790rpm DRY HIGH 20°C 650rpm COOLING LOW 21°C 790rpm COOLING AUTO LOW 22°C 930rpm RESTRICTED SWEATING 23°C 950rpm COOLING MIDDLE 24°C 1040rpm COOLING AUTO HIGH 25°C 1055rpm COOLING HIGH 26°C 1155rpm COOLING TURBO 27°C 780rpm PREVENTED COLD WIND 28°C 880rpm HEATING LOW 29°C 880rpm HEATING AUTO LOW 30°C 980rpm HEATING MIDDLE 31°C 1100rpm HEATING AUTO HIGH 32°C 1175rpm HEATING HIGH	OPEN
		0.3~4.5V ○ Except above x	x	Bit7	x							
2	1time	I.D Fan speed	WIRELESS	Model select		○	○	x	○	x		OFF
		○	x	Bit6	x							
3	1time	Hot keep	Power on	Model select		x	○	○	x	x		OFF
		x	x	Bit5	○							
4	1time	EEPROM	Test	Model select		x	x	x	x	x		OFF
		○	○	Bit4	x							
5	1time	EEPROM version	EEPROM version	Fan speed correction		x	x	○	x	x		OFF
		BIT7	x	BIT3	x							BIT7
6	1time	EEPROM version	EEPROM version	Fan speed correction		x	x	x	x	x	OFF	
		BIT6	x	BIT2	x						BIT6	○
7	1time	EEPROM version	EEPROM version	Fan speed correction		x	x	○	x	x	OFF	
		BIT5	x	BIT1	○						BIT5	○
8	1time	EEPROM version	EEPROM version	Fan speed correction		x	x	○	x	x	CLOSE	
		BIT4	○	BIT0	○						BIT4	○

2. AY-AP9FHR

STEPNo	Buzzer	LED				P. C Power	Outdoor Fan	4W-Valve	Compressor	Indoor Fan	Louver	
		Operation LED102 (RED)	Timer LED103 (YELLOW)	Turbo LED101 (GREEN)	P. C LED104 (BLUE)							
0	2times	Room temp	Heat-exchanger	○	○	x	x	x	x	OFF	OFF	
		7~42°C ○ Except above x	-2~45°C ○ Except above x									
1	1time	CT	Auto-restart	Model select		x	x	○	x	○	SETTING TEMP: AUTO 1255rpm HEATING TURBO 18°C 770rpm DRY LOW 19°C 820rpm DRY HIGH 20°C 650rpm COOLING LOW 21°C 820rpm COOLING AUTO LOW 22°C 1040rpm RESTRICTED SWEATING 23°C 1040rpm COOLING MIDDLE 24°C 1100rpm COOLING AUTO HIGH 25°C 1115rpm COOLING HIGH 26°C 1215rpm COOLING TURBO 27°C 800rpm PREVENTED COLD WIND 28°C 900rpm HEATING LOW 29°C 900rpm HEATING AUTO LOW 30°C 1050rpm HEATING MIDDLE 31°C 1130rpm HEATING AUTO HIGH 32°C 1205rpm HEATING HIGH	OPEN
		0.3~4.5V ○ Except above x	x	Bit7	x							
2	1time	I.D Fan speed	WIRELESS	Model select		○	○	x	○	x		OFF
		○	x	Bit6	○							
3	1time	Hot keep	Power on	Model select		x	○	○	x	x		OFF
		x	x	Bit5	x							
4	1time	EEPROM	Test	Model select		x	x	x	x	x		OFF
		○	○	Bit4	x							
5	1time	EEPROM version	EEPROM version	Fan speed correction		x	x	○	x	x		OFF
		BIT7	x	BIT3	x							BIT7
6	1time	EEPROM version	EEPROM version	Fan speed correction		x	x	x	x	x	OFF	
		BIT6	x	BIT2	x						BIT6	○
7	1time	EEPROM version	EEPROM version	Fan speed correction		x	x	○	x	x	OFF	
		BIT5	○	BIT1	○						BIT5	○
8	1time	EEPROM version	EEPROM version	Fan speed correction		x	x	○	x	x	CLOSE	
		BIT4	x	BIT0	○						BIT4	○

[3] DIAGNOSIS PROCEDURE

When indoor fan motor is out of order or compressor lock occurs, the compressor, indoor fan motor, outdoor fan motor, and louver are all stopped and the operation LED(red) turns on or off synchronously with the timing of the timer LED.

When the thermistor for room temperature or pipe temperature is open or short state, the operation LED turns on or off synchronously with the timing of the timer LED by pushing continuously for more than 5 seconds "AUX." button during suspension of operation.

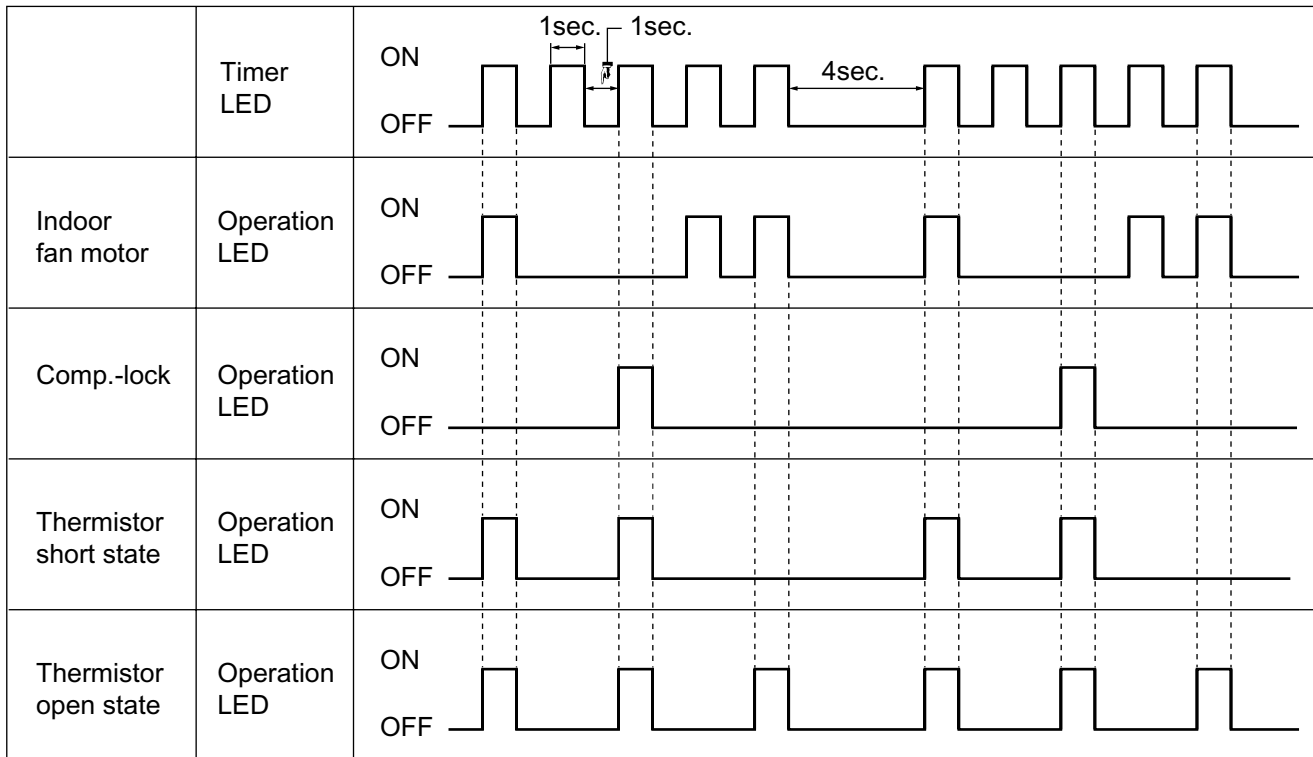

Timing chart of Timer LED and Operation LED of DIAGNOSIS PROCEDURE.

When "OI" button the remote controller or "AUX." button in the unit is pushed, the unit is free from DIAGNOSIS PROCEDURE.